



Alban Giacomo SpA

COMPANY WITH
QUALITY SYSTEM
CERTIFIED BY DNV GL
= ISO 9001 =

TECHNICAL MANUAL

LIFT & SLIDE

Basic 78/80 mm

XC Configuration

Layouts **A** & **E**, Layouts **B** & **F**

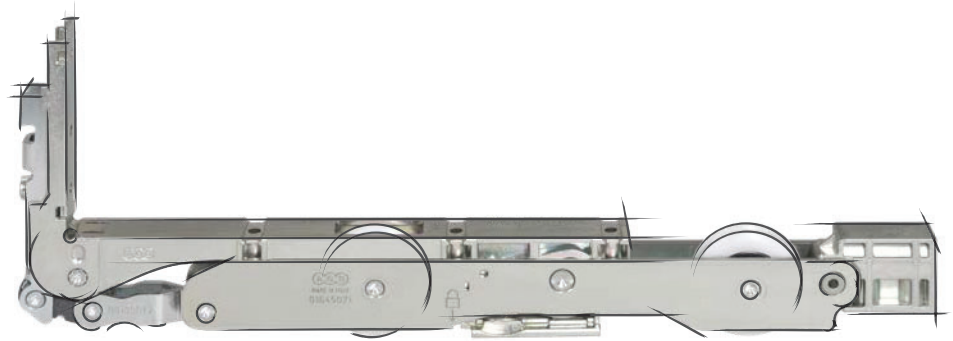

INTRODUCTION	3
Warnings	3
Symbolology and abbreviations	3
CONFIGURATION CHOICE AND BUILDING CALCULATION	4
Possible configurations developed in this manual	4
LAYOUTS A & E	5
Calculation of sliding sash dimensions	5
Hardware diagram with hooks lock	6
Hardware diagram with pins lock	8
Horizontal section	10
Jambs and listels details	12
Upper point vertical section with locking profile - fixed sash	14
Upper point vertical section with locking profile - sliding sash	14
Upper point vertical section with thermal pad (only for reduc. upper guide) - fixed sash	15
Upper point vertical section with thermal pad (only for reduc. upper guide) - sliding sash	15
Lower point vertical section - fixed sash	16
Lower point vertical section - sliding sash	16
Millings - Vertical section, upper point	17
Millings - Vertical section, lower point	18
Millings - Horizontal section, sliding sash	19
Millings - Horizontal section, fixed sash	20
Millings - Horizontal section, central point	21
Millings - Central point horizontal section, coaxial sashes	21
Formulas of components cut	22
LAYOUTS B & F	23
Calculation of dimensions, sliding sashes	23
Hardware diagram with hooks lock	24
Hardware diagram with pins lock	26
Horizontal section	28
Jambs and listels building details	30
Vertical section, upper point	31
Wood millings: frame jamb horizontal section	32
Wood millings: central point horizontal section	33
Wood millings: upper frame transom vertical section	33
Building details, layouts B & F	34
Formulas of components cut	35
LAYOUTS A & E, LAYOUTS B & F - ASSEMBLY OPERATIONS	36
Positioning of central listels on the sashes	36
Pad application on central jambs	36
Lock holes realisation	37
Accessories for single sash configuration with guide 22x22	38
Accessories for single sash configuration with guide 22x13	39
Accessories for coaxial sashes configuration with guide 22x13	40
Accessories for coaxial sashes configuration with guide 22x22	41
Sash assembly	42
Locking pins assembly	42
Frame corner joint (alternative solution)	43
Use of gas spring kit	43
STEPS FOR THE CONTROL OF PRODUCTION PROCESS (FPC)	44
TECHNICAL ATTACHMENTS	45

INTRODUCTION

Warnings



Possible changes regarding accessories, assembly and millings will be constantly reported with the periodic update of this manual. Therefore, we suggest to pay attention to the release of new versions in the website www.agb.it.







The producers who use the AGB Certification agreement must install glasses with the following minimum requirements: Minimum thickness 44.1/15/33.1 Shatterproof



Using a 45 mm thick frame instead of a 56 mm frame will change the heat transmittance and mechanical resistance characteristics of the door or window. Therefore, this configuration is also covered by AGB cascading. In this manual, both configurations are considered.

Symbology and abbreviations

HB	=	Sash height	G1	=	Solution detail with high/reduced upper guide
LB	=	Sash width	G2	=	Solution detail with guide 22X13
MET	=	Frame external measurement	G3	=	Solution detail with guide 22X22
SMT	=	Frame jamb thickness	M1	=	Detail solution with XC carriages
SMA	=	Sash jamb thickness	M2	=	Detail solution with XC S-Line carriages
LBF	=	Fixed sash width	S1	=	Detail solution with hooks lock
HET	=	Frame external height	S2	=	Detail solution with pins lock
STST	=	Frame upper transom thickness	C1	=	Solution with magnetic gaskets
LG	=	Glass width	C2	=	Solution with basic point
HG	=	Glass height	C4	=	Solution with Uni-V Mini central point
H	=	Component height	+₂₃	=	Reference page number for details
L	=	Component length			
Gap	=	5 mm			
	=	Silicone or suitable gasket			
	=	Neutral silicone with Primer			
	=	Pre-hole			
	=	EPDM tape			

Note. All the measurements are in millimeters

Note. Quotas related to the version "80 mm" are indicated in brackets

CONFIGURATION CHOICE AND BUILDING CALCULATION

Possible configurations developed in this manual

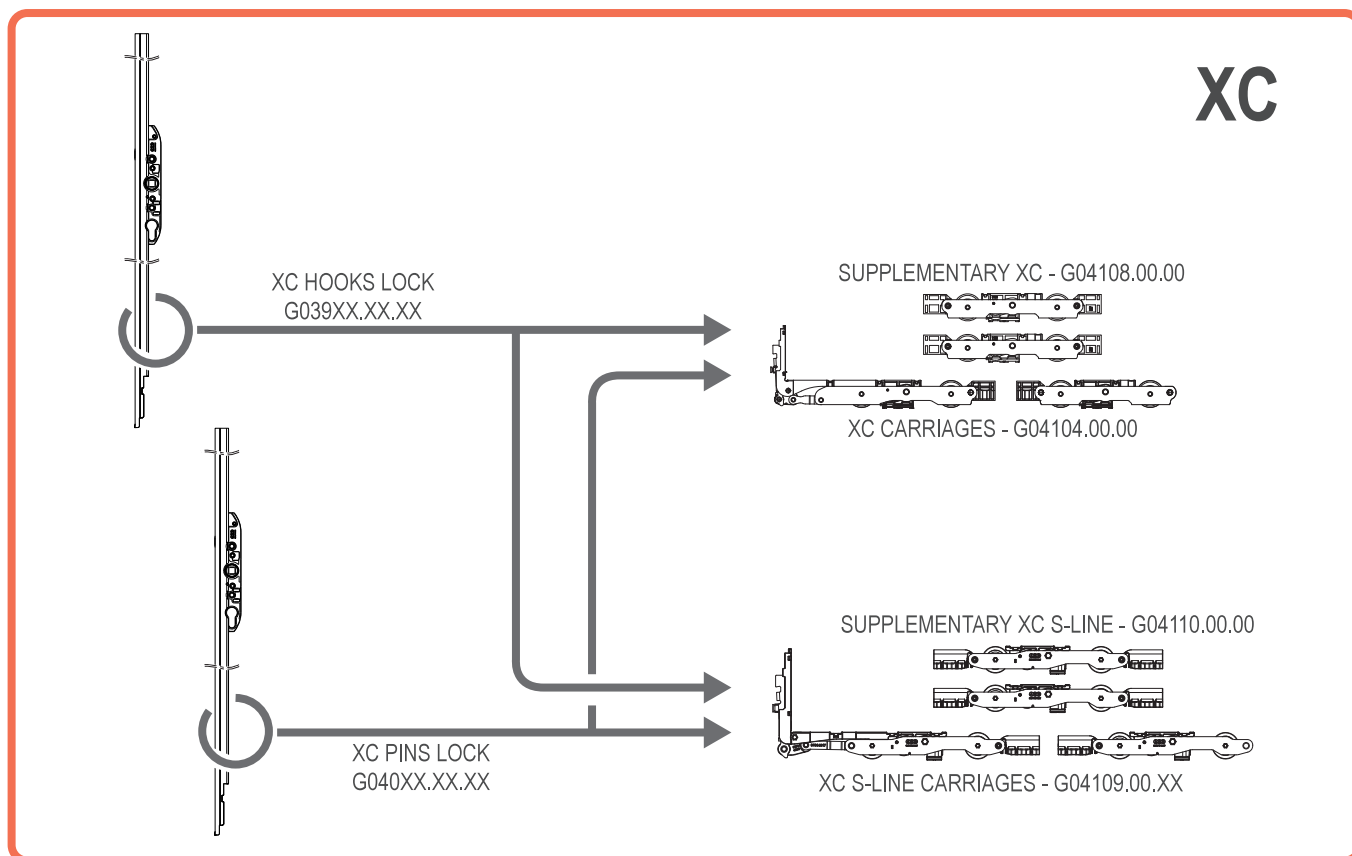

LAYOUTS A & E

- Sash with one transom in the lower part with possibility to have a basement.
- Vertical external gasket - lower: balloon with vulcanized edge in EPDM.
- Covering internal side gasket of the milling in EPDM.
- PVC upper gasket with wing.
- Water, air, wind and impact tests made in glass: 44.1/15/33.1 (minimum possible).
- Distance between the sashes 28 mm.
- Layout E made with symmetric central point and aluminium pin holder profile and extremity caps for gaps closing.
- External architrave cable with brush.

Calculation of sliding sash dimensions

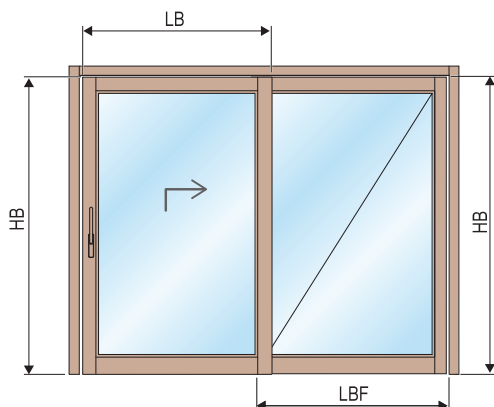

$A = 12$
 $\Rightarrow HB = HET - (STST+12+21)$

$A = 15$ (guide 22x22)
 $\Rightarrow HB = HET - (STST+15+21)$

(Tolerance HB $\pm 0,5$)

	G1	G2	G3
A = 12	✓	✓	✓
A = 15	✗	✗	✓

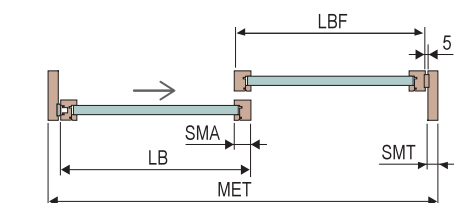
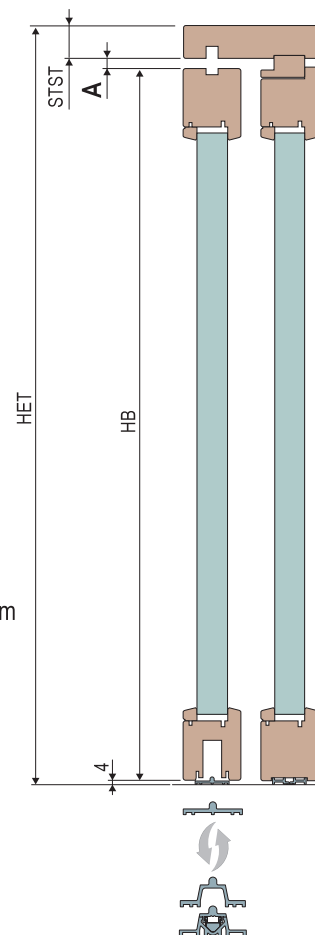

Layout A
 1 fixed sash and 1 sliding sash
 $LB = [MET-2x(SMT+5)]:2+SMA:2$
 Eg.: $[4000-2x(56+5)]:2+90:2$ LB = 1984 mm

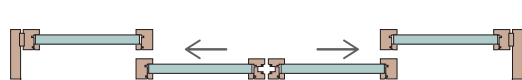

Layout E
 2 fixed sashes and 2 sliding sashes
 $LB = [MET-(2xSMT+3x5)]:4+SMA:2$



Layout D
 1 fixed sash and 2 sliding sashes
 $LB = [MET-2x(SMT+5)]:4+SMA:2$

Hardware diagram with hooks lock

- 1 Hooks lock**
G039EE.03.XX HB=1775-2150 Handle H = 1000
G039EE.04.XX HB=1925-2400 Handle H = 1000
G039EE.05.XX HB=2325-2750 Handle H = 1000
- 2 Additional hook kit - G05008.00.00**
- 3 Microventil. additional hook kit - G05010.00.00**
- 4 Second sash hooks lock**
GR39EE.03.01 HB=1775-2150 Handle H = 1000
GR39EE.04.01 HB=1925-2400 Handle H = 1000
GR39EE.05.01 HB=2325-2750 Handle H = 1000
- 5 Hooks extension 500 mm - G04600.01.01**
- 6 Covering profile 1000 mm - G04401.02.01**
- 7 Gas spring kit - GMG702.04.00**
- 8 XC basic carriages kit - G04104.00.00**
- 9 XC suppl. carriages kit - G04108.00.00**
- 10 XC S-Line carriages kit - G04109.00.00**
- 11 XC S-Line suppl. carriages kit - G04110.00.00**
- 12 Carriages connecting rod**
G04601.00.01 L=1000 G04601.00.03 L=1800
G04601.00.02 L=1400 G04601.00.04 L=2700
- 13 Handle fastening plate**
G05371.M5.00 hole M5
G05371.M6.00 hole M6
- 14 Anti-burglar plate kit - G05004.00.00**
- 15 Sensors**
G05006.00.86 Grey
G05006.00.93 Black
G05003.00.00 Clip
- 16 Lateral locking profile for hooks lock**
G01359.03.XX GR3 Predisposit. 2 hooks
G01359.04.XX GR4 Predisposit. 2 hooks
G01359.05.XX GR5 Predisposit. 2 hooks
G01359.13.XX GR3 Predisposit. 3 hooks
G01359.14.XX GR4 Predisposit. 3 hooks
G01359.15.XX GR5 Predisposit. 3 hooks
G01359.23.XX GR3 Predis. signal system
G01359.24.XX GR4 Predis. signal system
G01359.25.XX GR5 Predis. signal system
- 17 Extension for lock.prof. for hooks lock**
G01360.01.XX L=500
- 18 Coax. sashes lock. prof. for hooks lock + caps**
G01373.13.XX L=2075 HB=1775-2150 with hooks strik.
G01373.14.XX L=2325 HB=1925-2400 with hooks strik.
G01373.15.XX L=2750 HB=2325-2750 with hooks strik.
- 19 Extens. lock.prof. coax sashes for hooks, 500 mm**
G01364.01.XX with hooks striker
- 20 Striker for lock hook - G06201.00.XX**
- 21 Strik. for hook lock with signal syst. - G06203.00.XX**
- 22 Lower thermal pad - G01400.07.93**
- 23 Embedded upper guide 22x13**
G01000.01.XX L=3000 G01000.04.XX L=6000
G01000.02.XX L=4000 G01000.14.XX L=7000
G01000.03.XX L=5000
- 24 Shaped cap for "C" track 22x13 (B)**
- 25 Shaped cap for low. rail (B) (C) (F)**
- 26 Rear lower covering cap (B) (F)**
- 27 Cap and glider for front upper guide (B)**
- 28 Cap and glider for rear upper guide (B)**
- 29 Embedded guide reduced door stop - G0204.00.JJ.702**
- 30 Embedded upper guide 22x22**
G01002.01.XX L=3000 G01002.04.XX L=6000
G01002.02.XX L=4000 G01002.05.XX L=7000
G01002.03.XX L=5000
- 31 Shaped cap for embedded guide 22x22 (C)**
- 32 Front glider (C)**
- 33 Rear glider (C)**
- 34 Rear lower cap (C)**
- 35 Glider fastening device (C)**
- 36 Steiker (C) (E)**
- 37 Cover (C)**
- 38 Magnetic striker (D) (E)**
- 39 Opening brake (D)**
- 40 Closing brake (E)**
- 41 Reduced upper guide**
G01734.01.XX L=3000 G01734.04.XX L=6000
G01734.02.XX L=4000 G01734.14.XX L=7000
G01734.03.XX L=5000
- 42 Shaped cap for upper guide (F)**
- 43 2 mm adapter (F) (B) (C)**
- 44 Terminal cap for lock (F)**
- 45 Rear upper cov. cap (F)**
- 46 Door stop**
G00204.00.91 White G00204.00.93 Black
G00204.00.86 Grey
- 47 Upper locking profile**
G02403.15.01 L=1500
G02403.20.01 L=2000
G02403.30.01 L=3000
- 48 Low rail**
G00738.01.XX L=3000
G00738.02.XX L=4000
G00738.03.XX L=6000
- 49 Profile for "C" up. and low. guide**
G01739.01.XX L=3000 G01739.03.XX L=5000
G01739.02.XX L=4000 G01739.04.XX L=6000
- 50 Snap-in rail for "C" track**
G02739.01.XX L=3000 G02739.03.XX L=5000
G02739.02.XX L=4000 G02739.04.XX L=6000
- 51 High rail kit + snap-in rail**
G01104.01.XX L=3000 G01104.03.XX L=5000
G01104.02.XX L=4000 G01104.04.XX L=6000
- 52 High rail fastening clip and slid. profile - G01110.01.00**
- 53 High rail**
G00739.01.XX L=3000
G00739.02.XX L=4000
G00739.03.XX L=6000
- 54 Floor upp. prof. for fixed sash**
G00760.00.01 L=1500 G00760.00.03 L=2500
G00760.00.02 L=2000 G00760.00.04 L=3000
- 55 Uni-V central point kit**
G02208.25.KK L=2500
G02208.31.KK L=3100
G02208.40.KK L=4000
- 56 Uni-V central point caps kit**
G01610.DX.93 Right
G01610.SX.93 Left
- 57 Uni-V Mini central point kit**
G02211.25.KK L=2500 G02211.40.KK L=4000
G02211.31.KK L=3100
- 58 Uni-V Mini central point caps kit**
G01623.DX.93 Destro G01623.SX.93 Left
- 59 External side gasket (balloon) (G)**
G020DX.09.93 - G020SX.09.93 L1500 x H2500
G02000.08.93 L3000 x H3000
- 60 Internal side gasket L150 m - G02004.15.93 (G)**
- 61 PVC upper flexible gasket**
G00733.02.01 L=40
G00733.02.02 L=200
- 62 Flexible gasket for central point**
G00733.04.01 L=40
G00733.04.02 L=200
- 63 Brush for decompression chamber**
G02002.16.00 L=1600 G02002.31.00 L=3100
G02002.25.00 L=2500 G02002.31.20 L=3100 (tube)
G02002.25.20 L=2500 (tube)
- 64 Upper thermal pad for reduced guide**
G01413.12.0B 120 mm
- 65 Expanded PVC gasket for rails - G00733.06.00**
- 66 EPDM gasket - G01416.17.00**
- 67 XC anti-derailed device - G01611.02.00**
- 68 Rod guide - G05102.00.00**
- 69 S-Line anti-derailed device - G01611.01.00**
- 70 S-Line rod guide - G05104.00.00**
- 71 Handle access. kit for 78&92 thick.**
G05390.00.00 screws M5
G05390.01.00 screws M6
- 72 Cap for supporting profile - G00760.00.00**
- 73 Connecting kit jamb-transom - G00728.00.23**
- 74 Handle**

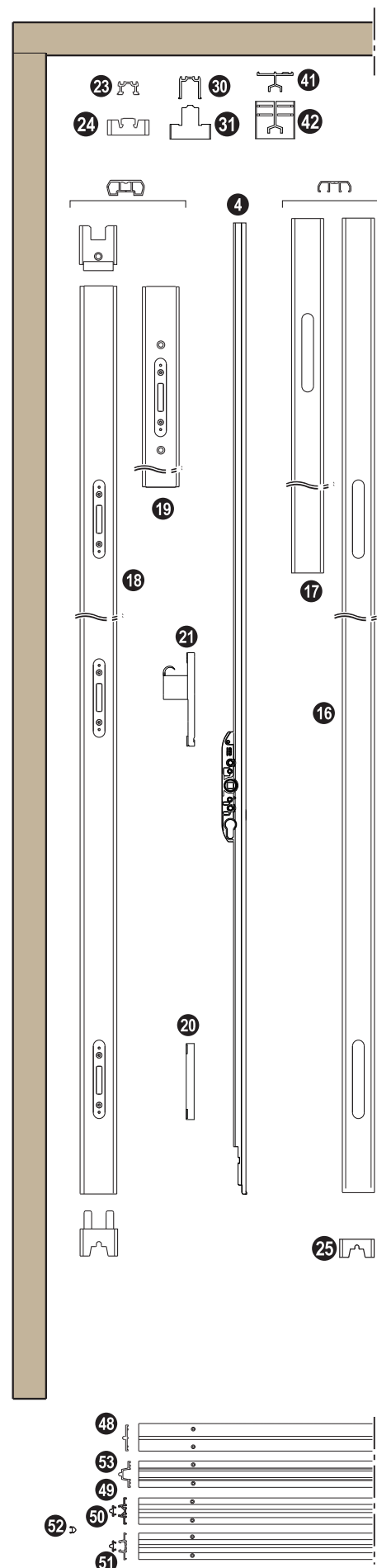

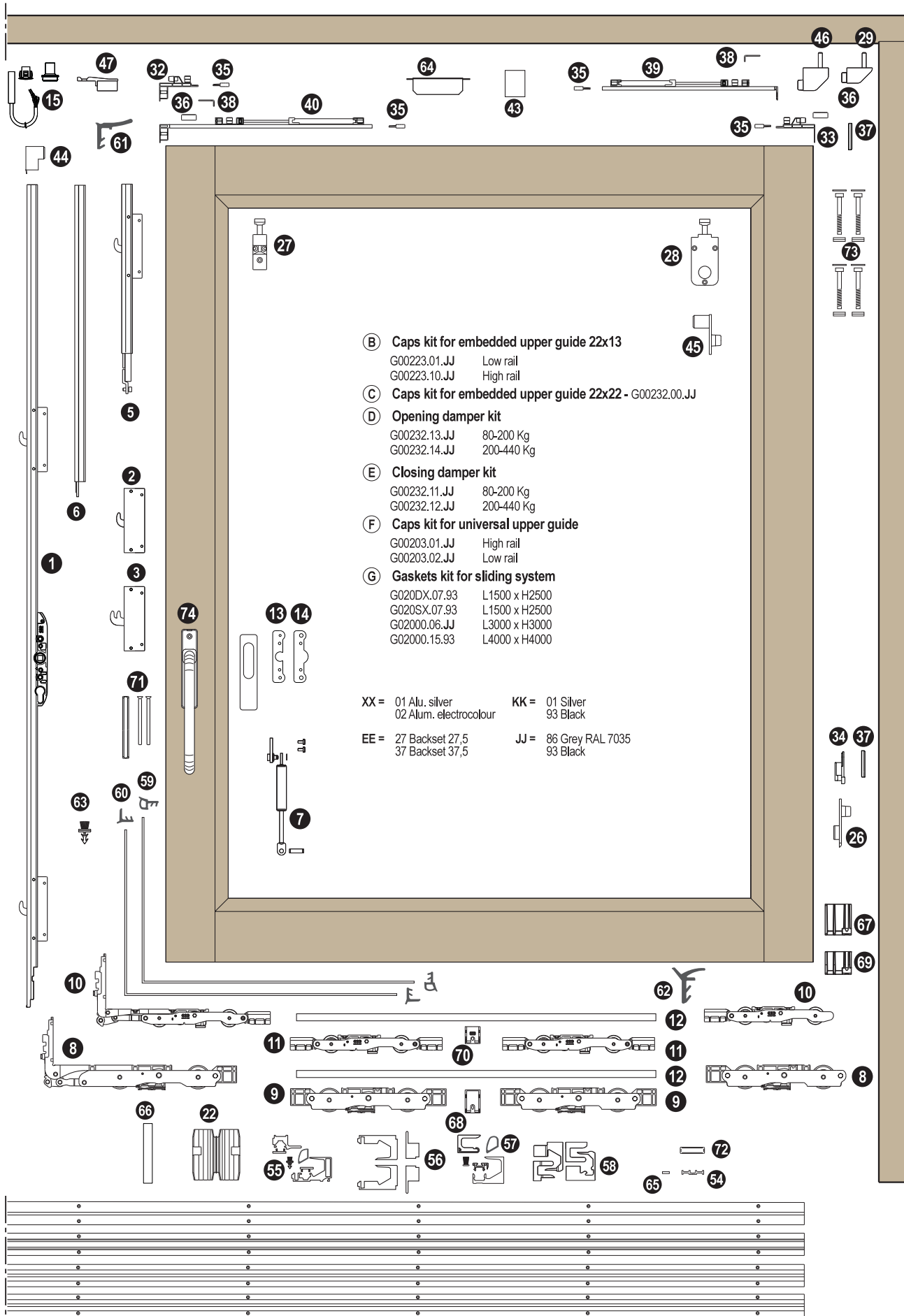

Hardware diagram with pins lock

- 1 Pins lock**
G040EE.01.XX Handle H = 400 SH=800-1200
G040EE.02.XX Handle H = 400 SH=1170-1800
G040EE.03.XX Handle H = 1000 SH=1770-2150
G040EE.04.XX Handle H = 1000 SH=1920-2400
G040EE.05.XX Handle H = 1000 SH=2401-2750
- 2 Pins extension 500 mm** - G04401.01.01
- 3 Covering profile 1000 mm** - G04401.02.01
- 4 Gas spring kit** - GMG702.04.00
- 5 XC basic carriages kit** - G04104.00.00
- 6 XC suppl. carriages kit** - G04108.00.00
- 7 XC S-Line carriages kit** - G04109.00.00
- 8 XC S-Line supp. carriages kit** - G04110.00.00
- 9 Carriages connecting rod**
G04601.00.01 L=1000 G04601.00.03 L=1800
G04601.00.02 L=1400 G04601.00.04 L=2700
- 10 Handle fastening plate**
G05371.M5.00 hole M5
G05371.M6.00 hole M6
- 11 Anti-burglar plate kit** - G05004.00.00
- 12 Sensors**
G05006.00.86 Grey
G05006.00.93 Black
G05003.00.00 Clip
- 13 Pin holder profile for lateral point**
G01341.00.XX L=1800 HB=800-1800
G01341.01.XX L=2900 HB=1770-2900
G01341.02.XX L=2900 HB=2401-2900
- 14 Lock. prof. for coaxial sashes + caps**
G01361.01.XX L=1125 HB=810-1200
G01361.02.XX L=1725 HB=1175-1800
G01361.03.XX L=2075 HB=1775-2150 with caps
G01361.04.XX L=2325 HB=1925-2400
G01361.05.XX L=2750 HB=2325-2750

G01340.01.XX L=1125 HB=810-1200
G01340.02.XX L=1725 HB=1175-1800 with caps and ventilation pin
G01340.03.XX L=2075 HB=1775-2150
G01340.04.XX L=2325 HB=1925-2400
G01340.05.XX L=2750 HB=2325-2750
- 15 Coax. sashes lock. prof. extens. for pins, 500 mm**
G01361.97.XX
- 16 Coax. sashes lock. prof. extens. for pins, 1000 mm**
G01757.00.XX
- 17 Pin**
G40728.00.03 for closing
G04902.01.00 for ventilation
- 18 Lower thermal pad** - G01400.07.93
- 19 Embedded upper guide 22x13**
G01000.01.XX L=3000 G01000.04.XX L=6000
G01000.02.XX L=4000 G01000.14.XX L=7000
G01000.03.XX L=5000
- 20 Shaped cap for "C" track 22x13 (B)**
- 21 Shaped cap for low. rail (B) (C) (F)**
- 22 Rear low. covering cap (B) (F)**
- 23 Cap and glider for front upper guide (B)**
- 24 Cap and glider for rear upper guide (B)**
- 25 Reduc. door stop for embedd. guide** - G0204.00.JJ.702
- 26 Embedded upper guide 22x22**
G01002.01.XX L=3000 G01002.04.XX L=6000
G01002.02.XX L=4000 G01002.14.XX L=7000
G01002.03.XX L=5000
- 27 Shaped cap for embedd. guide 22x22 (C)**
- 28 Front glider (C)**
- 29 Rear glider (C)**
- 30 Rear lower pad (C)**
- 31 Glider fastening device (C)**
- 32 Striker (C) (E)**
- 33 Cover (C)**
- 34 Magnetic striker (D) (E)**
- 35 Opening brake (D)**
- 36 Closing brake (E)**
- 37 Reduced upper guide**
G01734.01.XX L=3000 G01734.04.XX L=6000
G01734.02.XX L=4000 G01734.14.XX L=7000
G01734.03.XX L=5000
- 38 Shaped cap for upper guide (F)**
- 39 2 mm thick. (F) (B) (C)**
- 40 Terminal cap for lock (F)**
- 41 Rear upper covering cap (F)**
- 42 Door stop**
G00204.00.91 White G00204.00.93 Black
G00204.00.86 Grey
- 43 Upper locking profile**
G02403.15.01 L=1500
G02403.20.01 L=2000
G02403.30.01 L=3000
- 44 Low rail**
G00738.01.XX L=3000
G00738.02.XX L=4000
G00738.03.XX L=6000
- 45 Profile for up. and low. "C" track**
G01739.01.XX L=3000 G01739.03.XX L=5000
G01739.02.XX L=4000 G01739.04.XX L=6000
- 46 Snap-in rail for "C" track**
G02739.01.XX L=3000 G02739.03.XX L=5000
G02739.02.XX L=4000 G02739.04.XX L=6000
- 47 High rail kit + snap-in profile**
G01104.01.XX L=3000 G01104.03.XX L=5000
G01104.02.XX L=4000 G01104.04.XX L=6000
- 48 High rail fast. kit and sliding prof.** - G01110.01.00
- 49 High rail**
G00739.01.XX L=3000
G00739.02.XX L=4000
G00739.03.XX L=6000
- 50 Floor supp. prof. for fixed sash**
G00760.00.01 L=1500 G00760.00.03 L=2500
G00760.00.02 L=2000 G00760.00.04 L=3000
- 51 Uni-V central point kit**
G02208.25.KK L=2500
G02208.31.KK L=3100
G02208.40.KK L=4000
- 52 Uni-V central point caps kit**
G01610.DX.93 Destro
G01610.SX.93 Sinistro
- 53 Uni-V Mini central point kit**
G02211.25.KK L=2500 G02211.40.KK L=4000
G02211.31.KK L=3100
- 54 Uni-V Mini central point caps kit**
G01623.DX.93 Right G01623.SX.93 Left
- 55 External side gasket (balloon) (G)**
G020DX.09.93 - G020SX.09.93 L1500 x H2500
G02000.08.93 L3000 x H3000
- 56 Internal side gasket L150 m - G02004.15.93 (G)**
- 57 PVC upper flexible gasket**
G00733.02.01 L=40
G00733.02.02 L=200
- 58 Flexible gasket for central point**
G00733.04.01 L=40
G00733.04.02 L=200
- 59 Brush for decompression chamber**
G02002.16.00 L=1600 G02002.31.00 L=3100
G02002.25.00 L=2500 G02002.31.20 L=3100 (tube)
G02002.25.20 L=2500 (tube)
- 60 Upper thermal pad for reduced guide**
G01413.12.0B 120 mm
- 61 Expand. PVC gasket for rails** - G00733.06.00
- 62 EPDM gasket** - G01416.17.00
- 63 XC anti-derailed device** - G01611.02.00
- 64 Rod guide** - G05102.00.00
- 65 S-Line anti-derailed device** - G01611.01.00
- 66 S-Line rod guide** - G05104.00.00
- 67 Handle access. kit for 78&92 thick.**
G05390.00.00 screws M5
G05390.01.00 screws M6
- 68 Cap for supporting profile** - G00760.00.00
- 69 Conn. kit jamb - transom** - G00728.00.23
- 70 Handle**

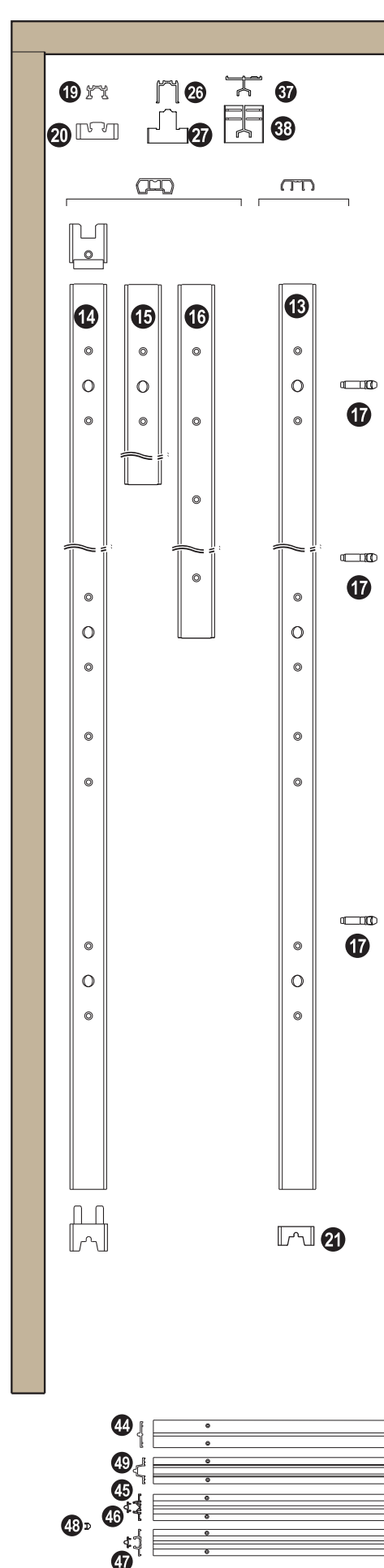

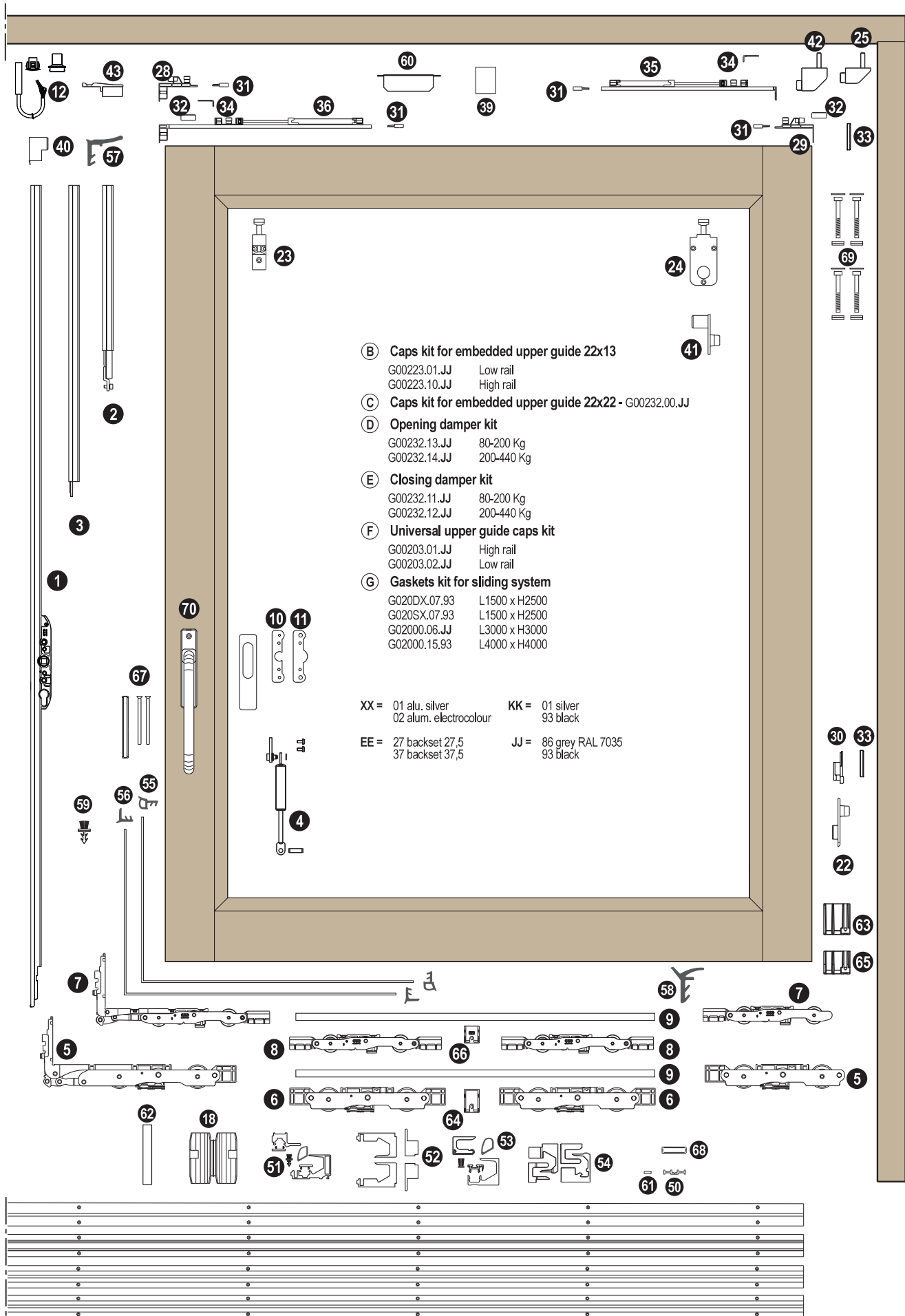

Horizontal section

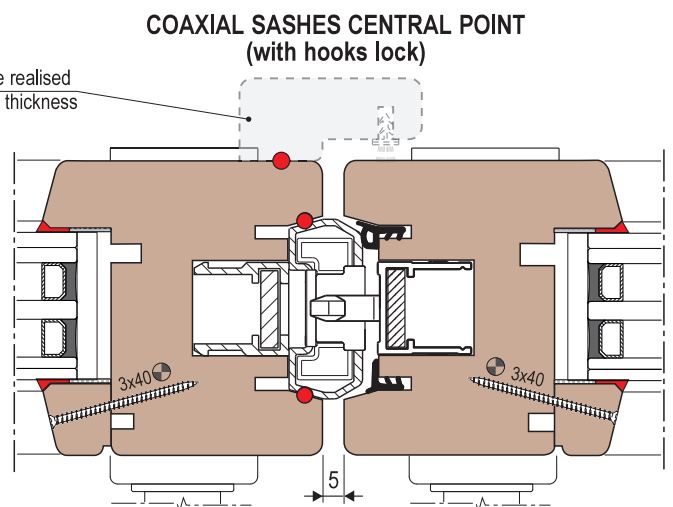
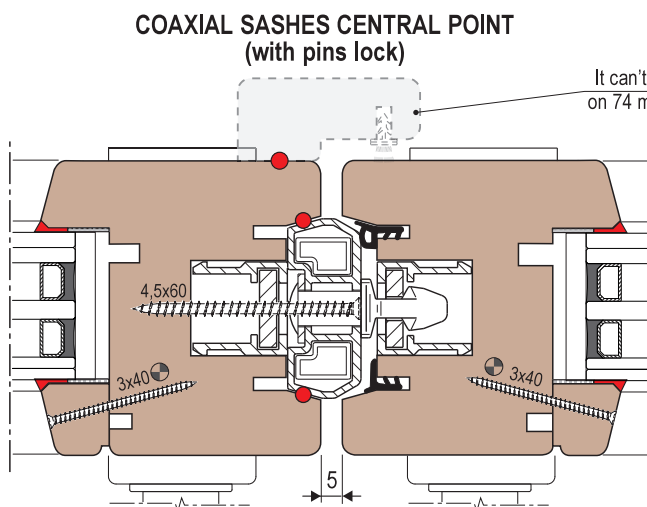
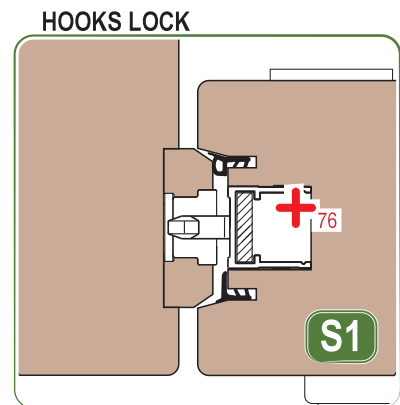
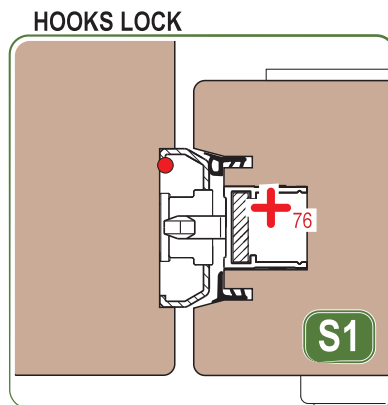
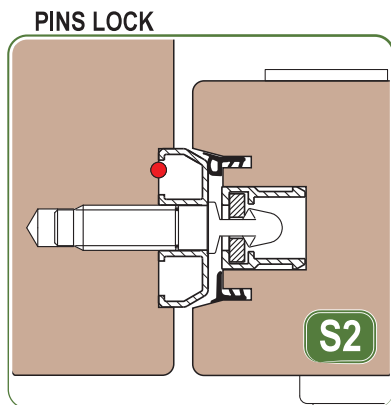
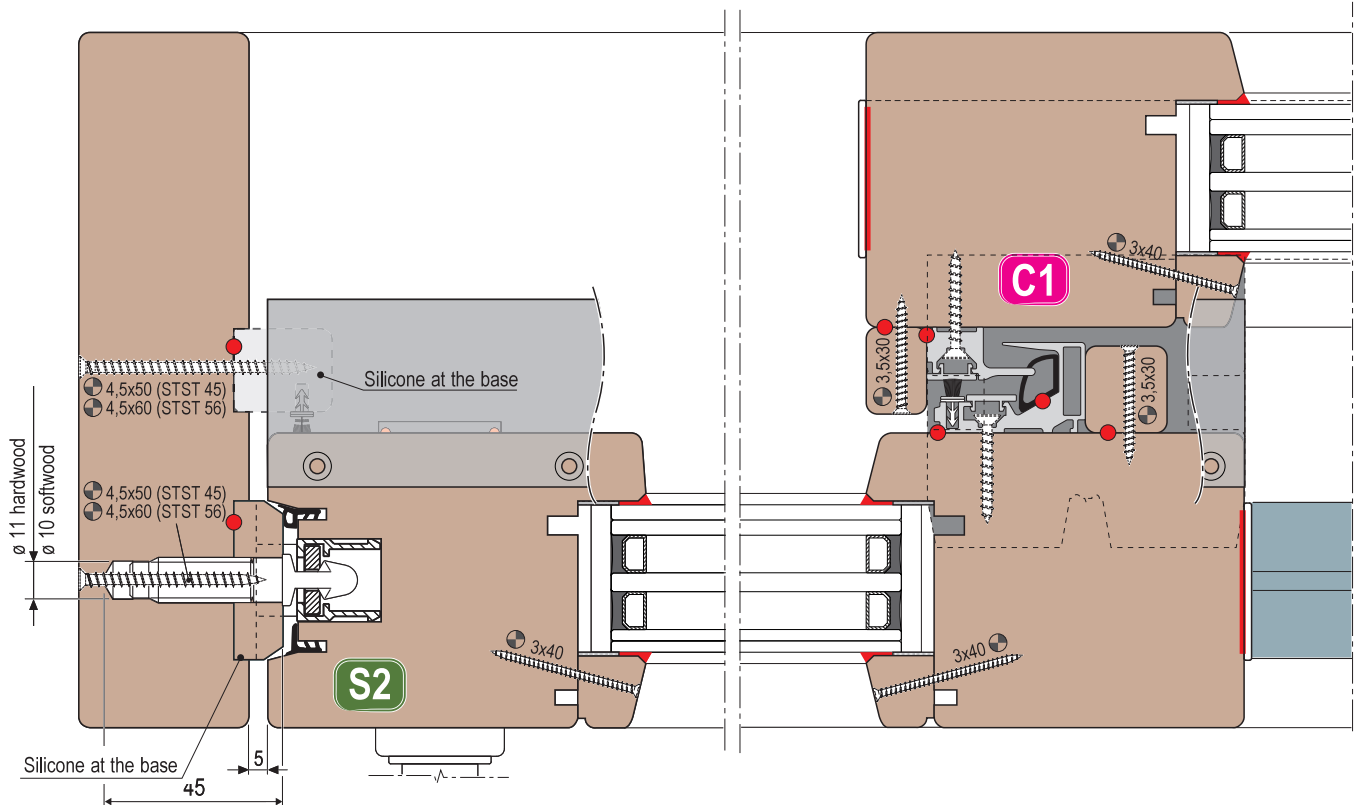

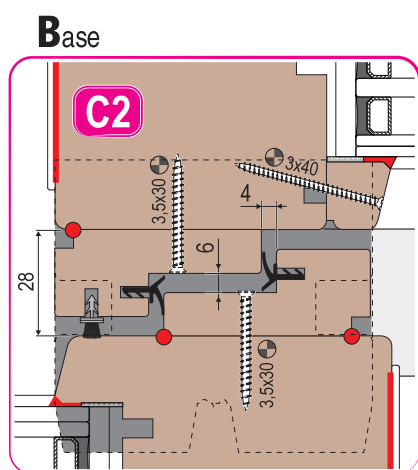
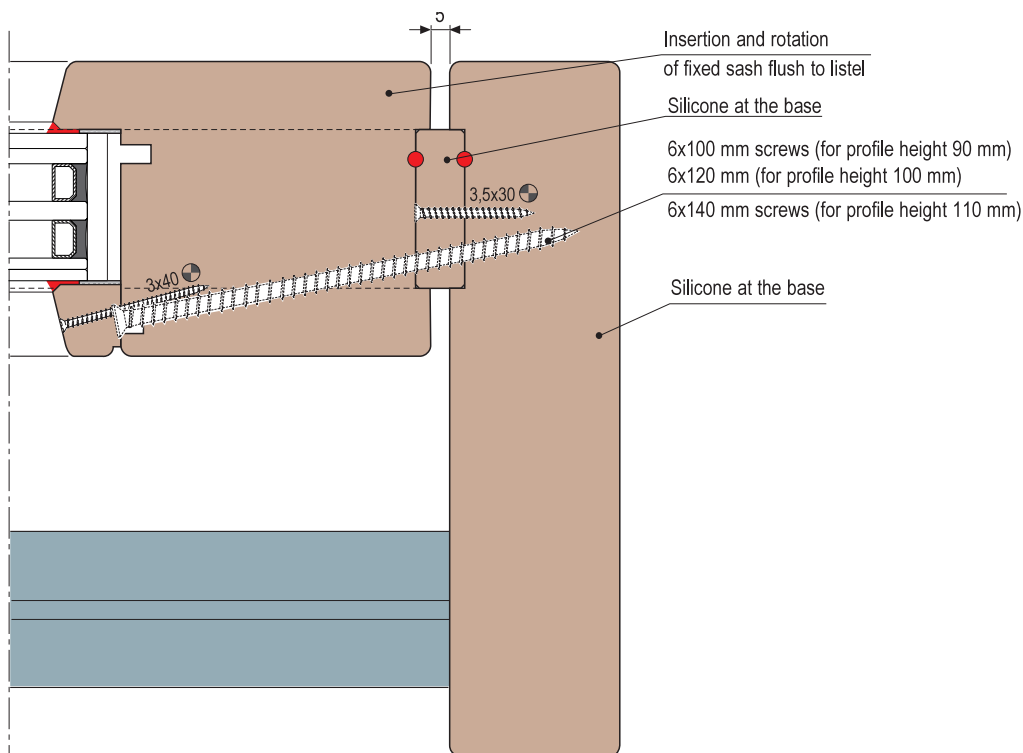

Align the pad to the sash jamb

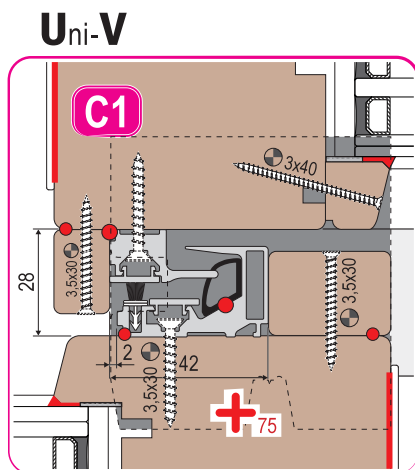

Align the pad to the sash jamb

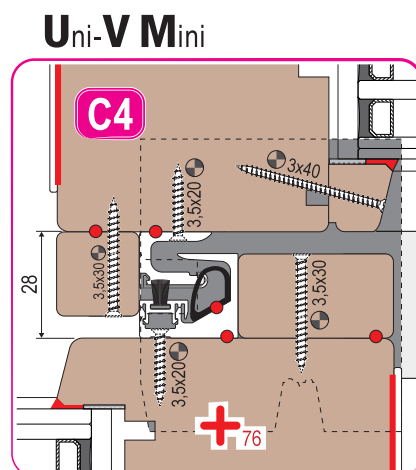

Align the pad to the sash jamb

	Uni-V	Uni-V Mini	Basic
Sash section width 74	X = 26	X = 34	X
Sash section width 90	X = 16	X = 18	-
Sash section width 100	X = 6	X = 8	-
Sash section width 110	-	-	-

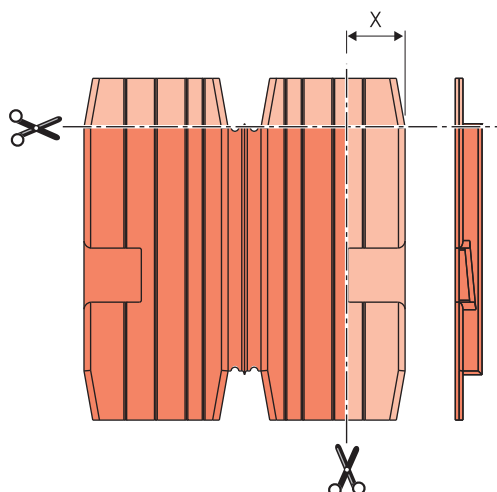

Jambs and listels details



As an example, the picture represents a case with 22X22 upper guide; the use of other guides needs different accessories even if they are assembled in the same way.

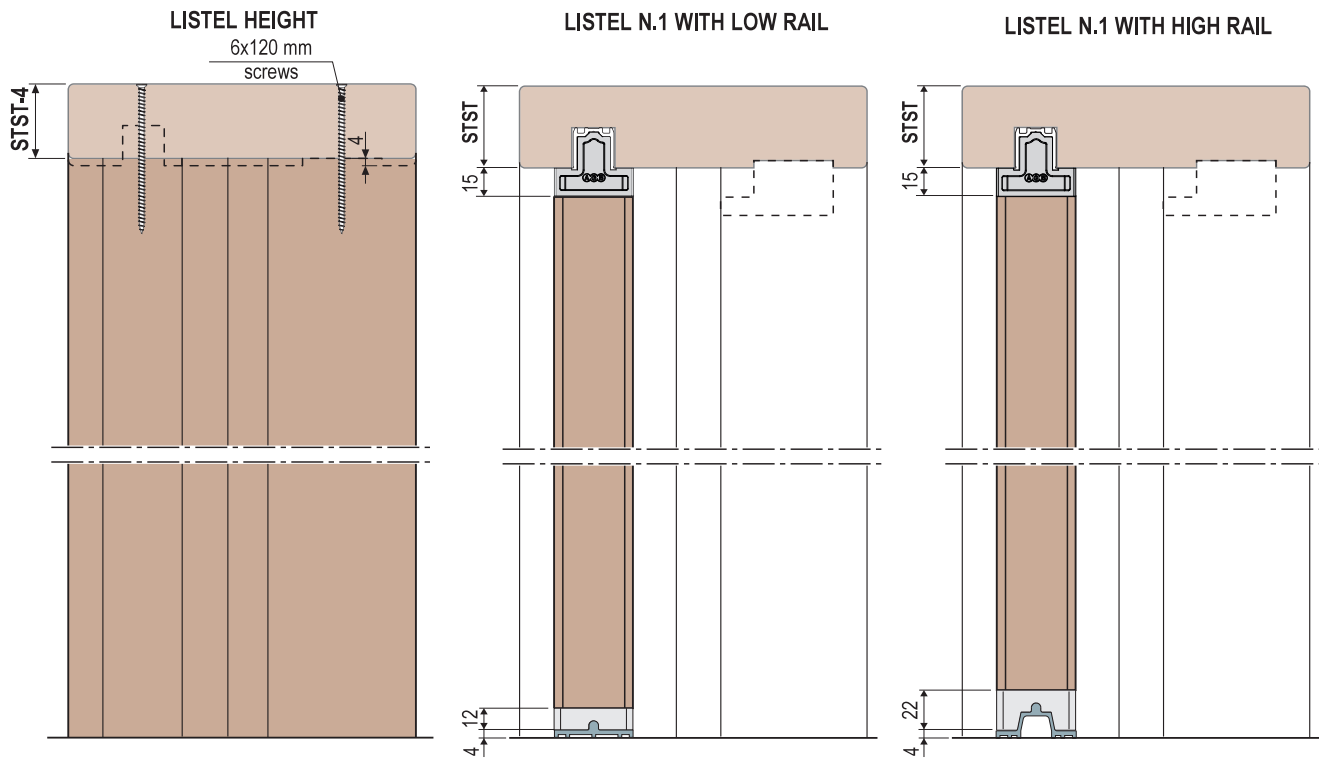

CAP CUT DETAIL
(only with low rail)



As an example, the picture represents a case with 22X22 upper guide; the use of other guides needs different accessories even if they are assembled in the same way.

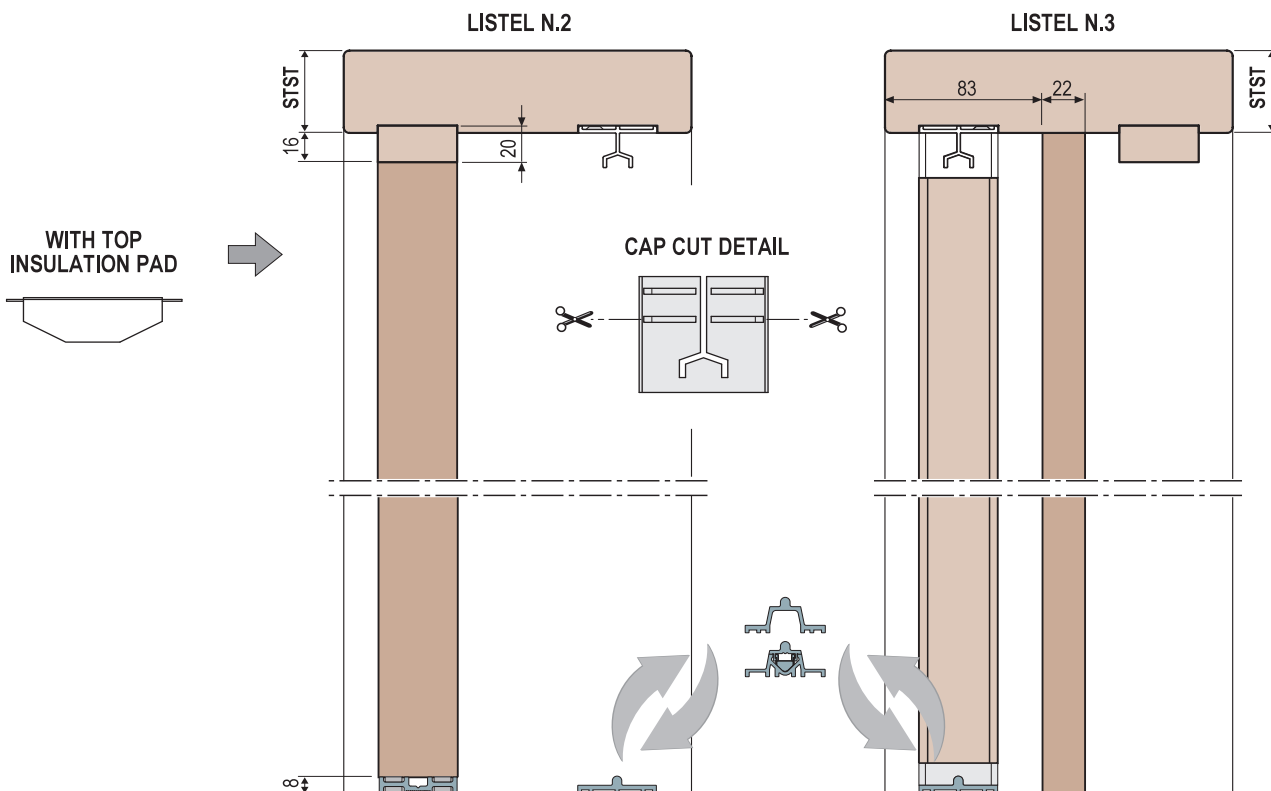
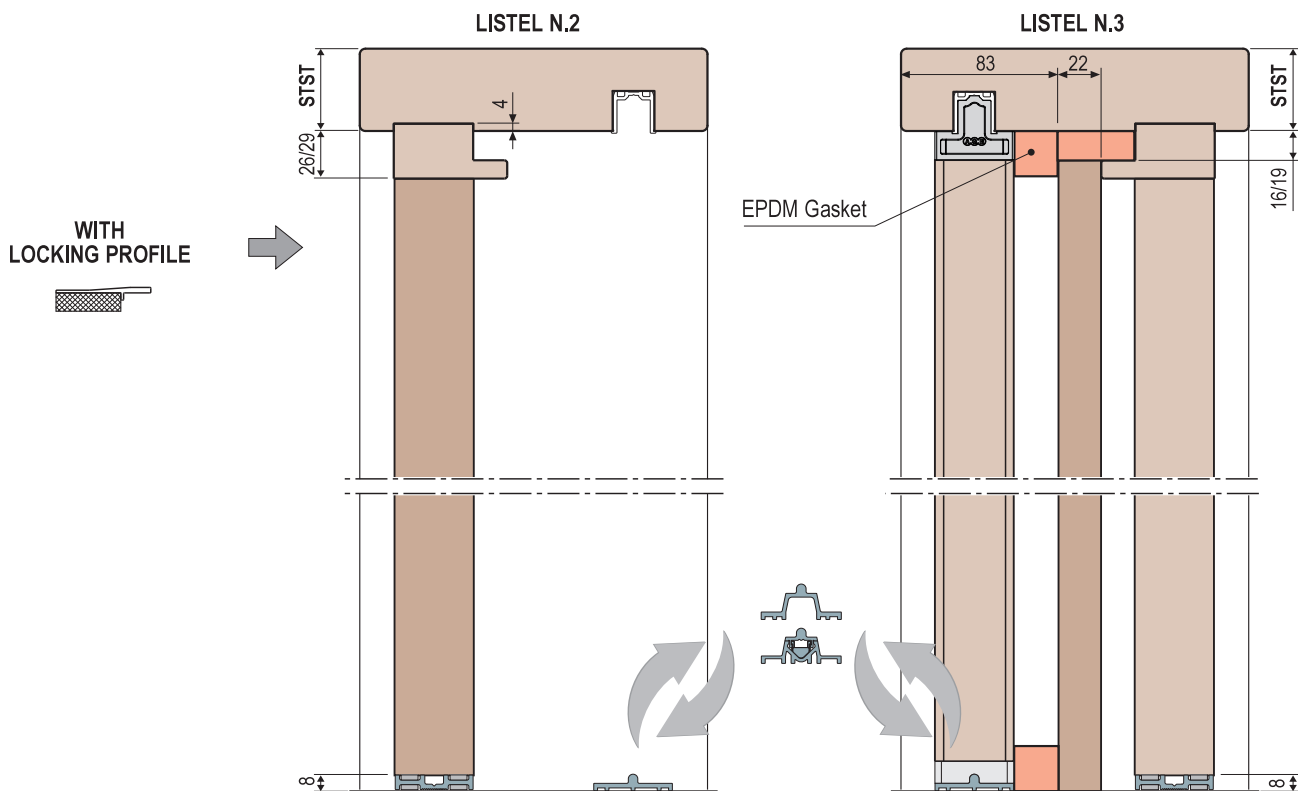

Upper point vertical section with locking profile - fixed sash

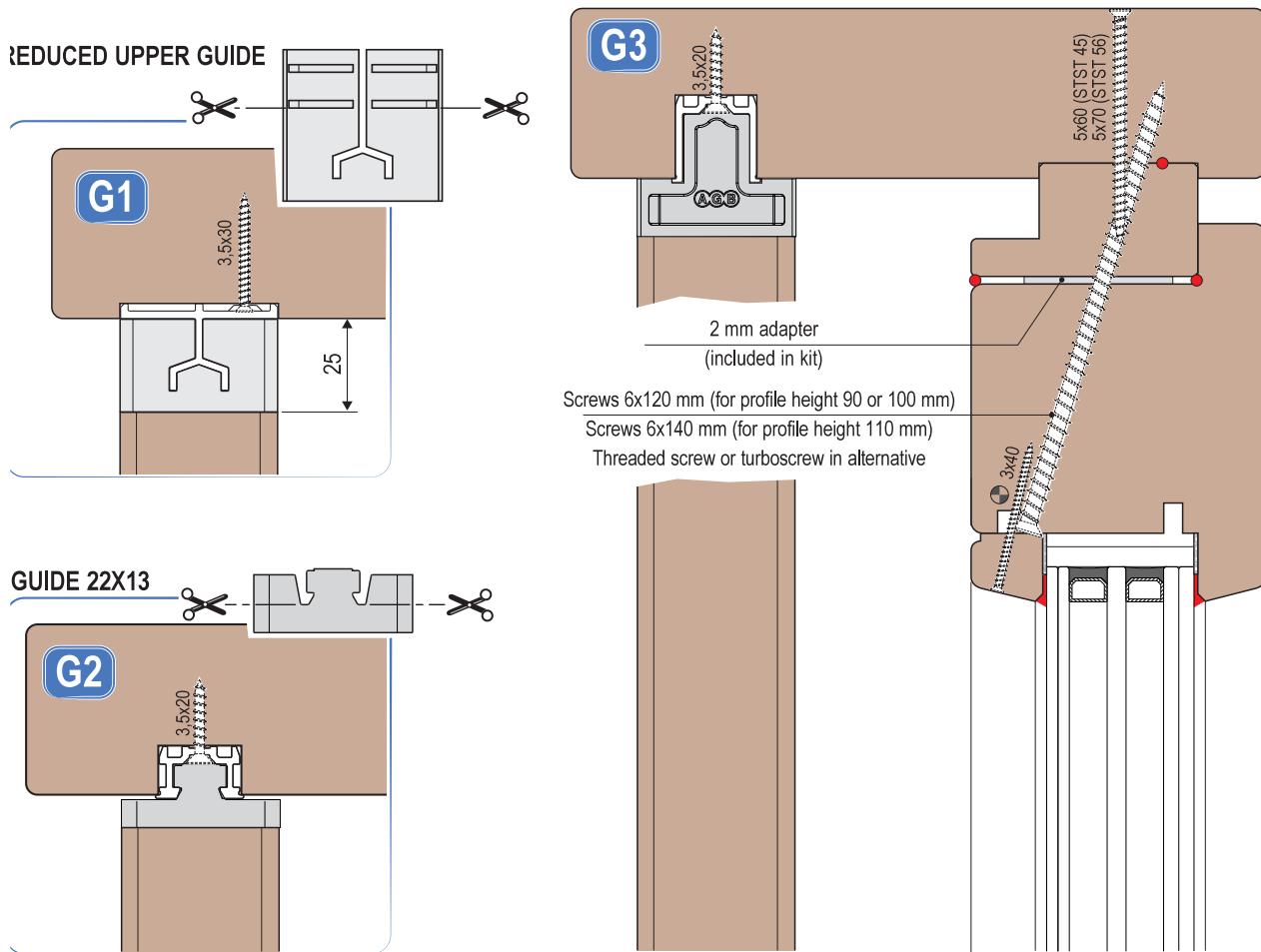

Upper point vertical section with locking profile - sliding sash

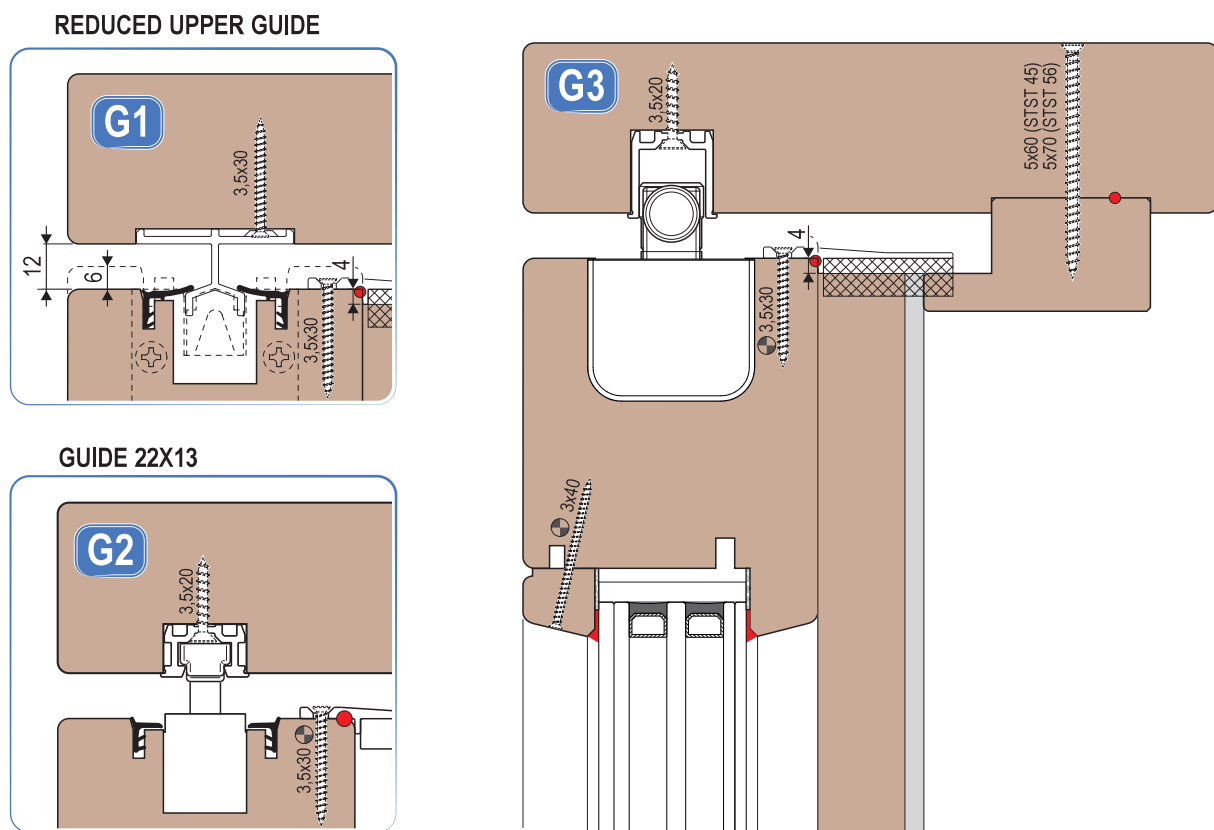

Upper point vertical section with thermal pad (only for reduc. upper guide) - fixed sash

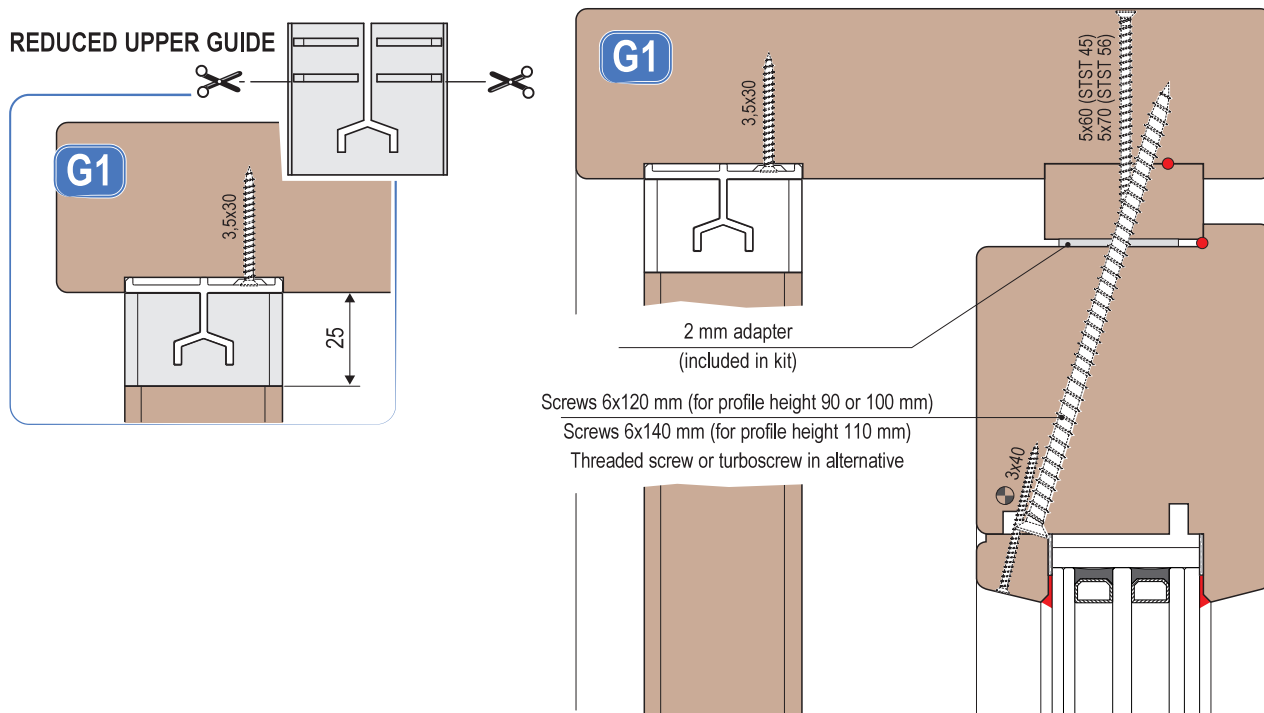

Upper point vertical section with thermal pad (only for reduc. upper guide) - sliding sash

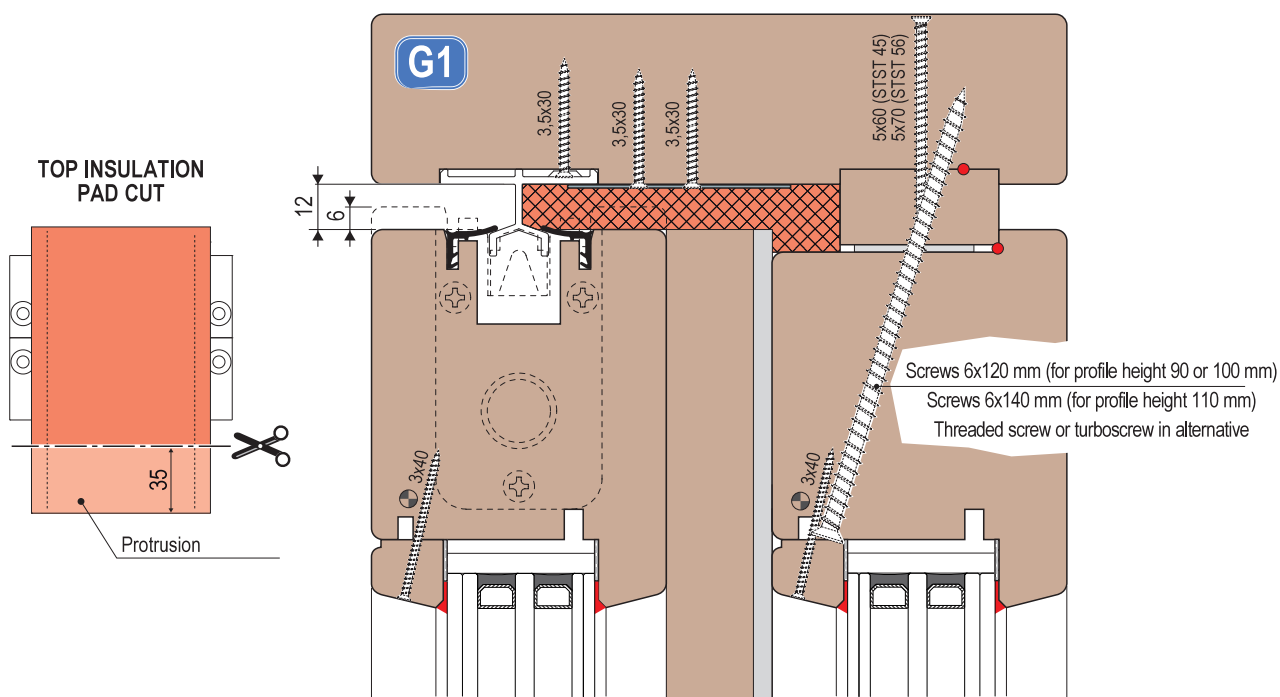

Lower point vertical section - fixed sash

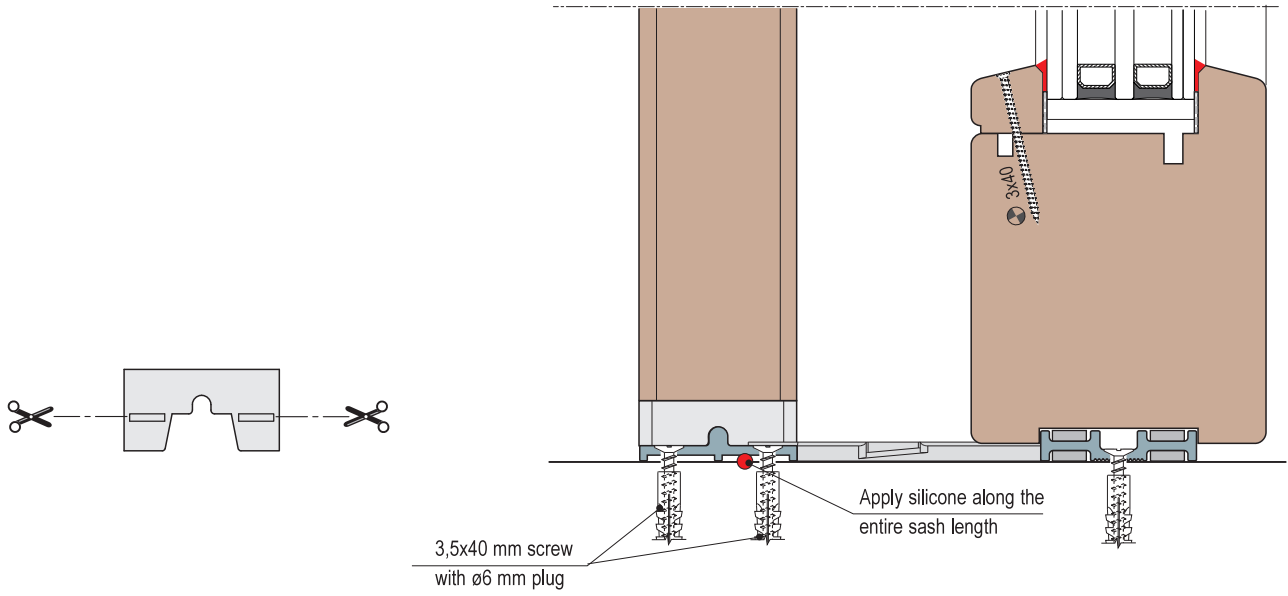

Lower point vertical section - sliding sash

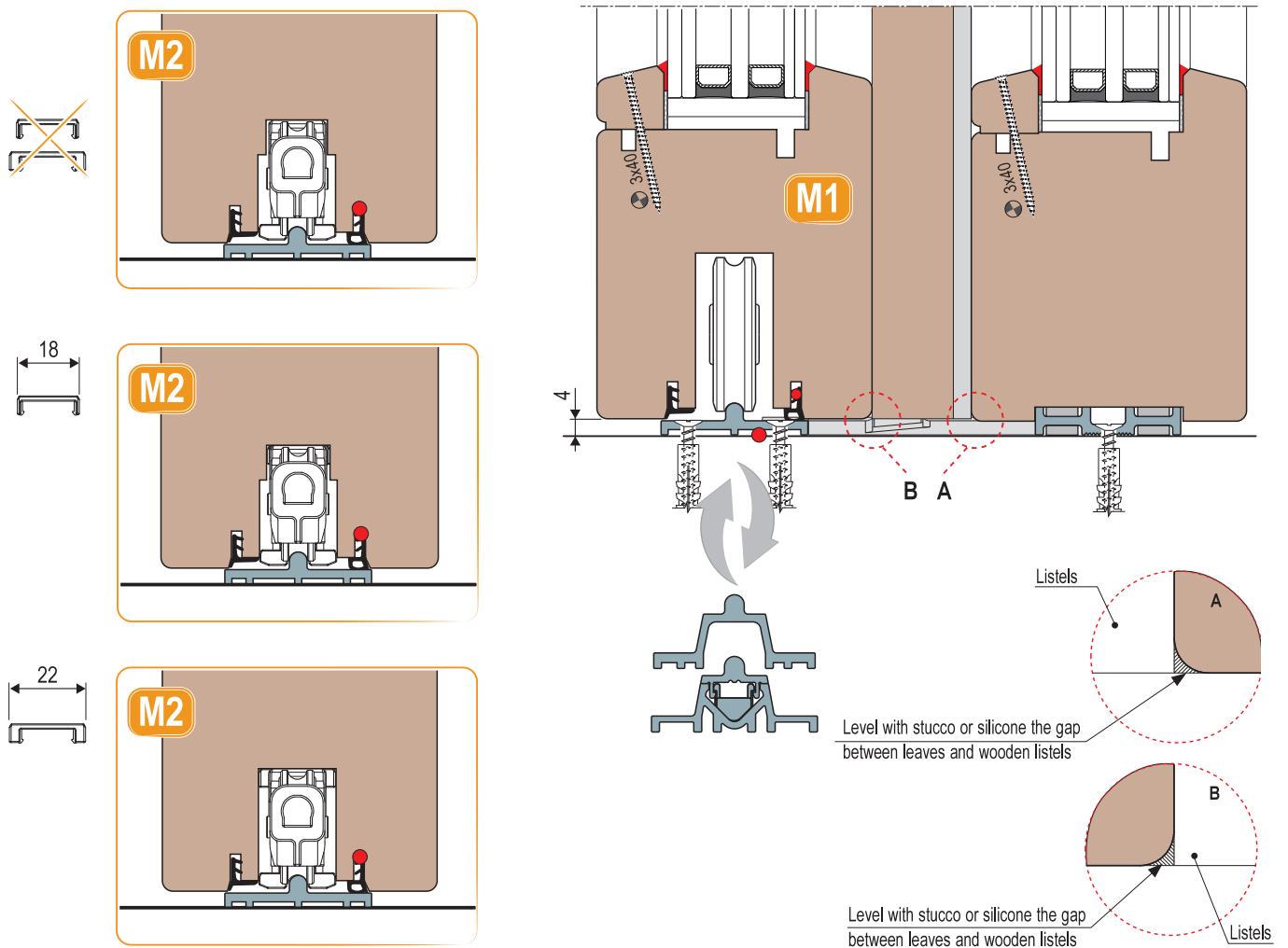

Millings - Vertical section, upper point

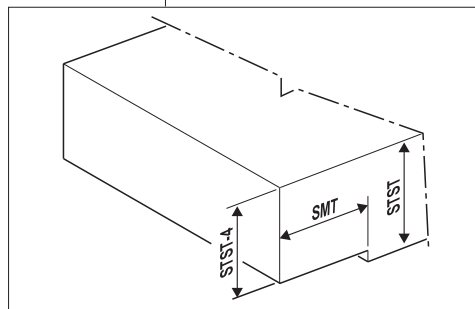
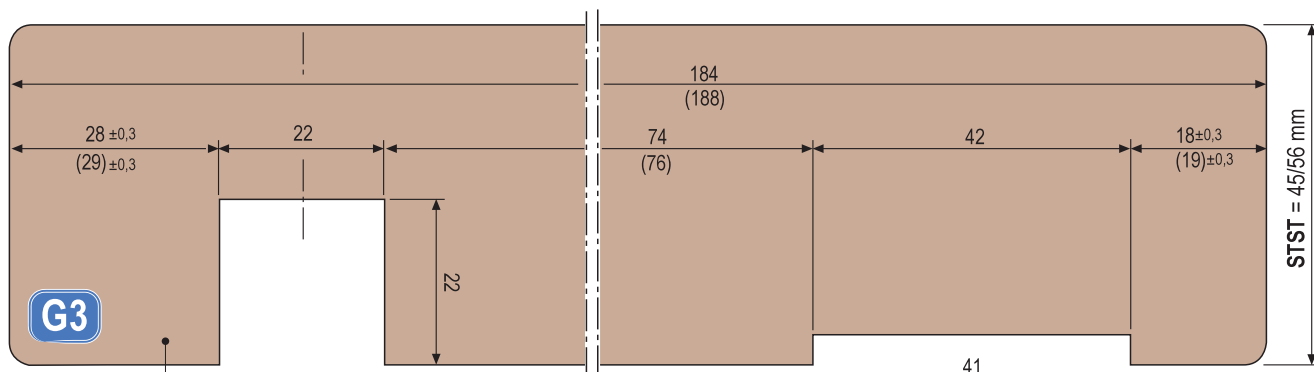

Layout E
MET-2xSMT+4
Layout A
MET-2xSMT+2

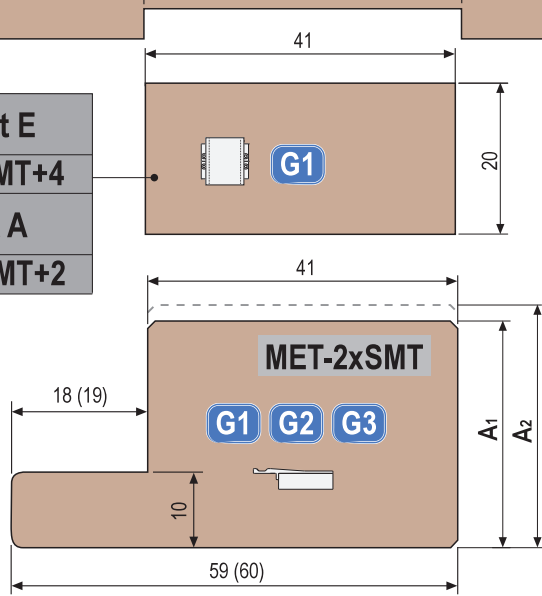

	16		6
--	----	--	---

	G1	G2	G3
A ₁ = 30	✓	✓	✓
A ₂ = 33	✗	✗	✓

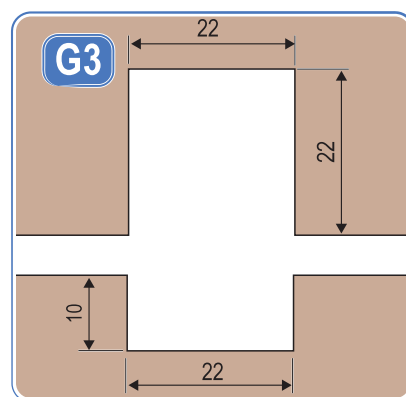
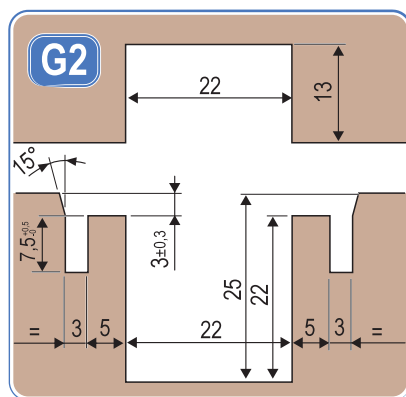
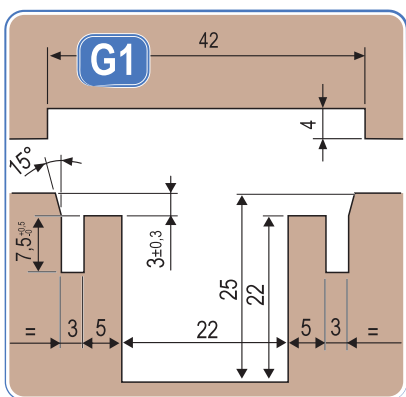
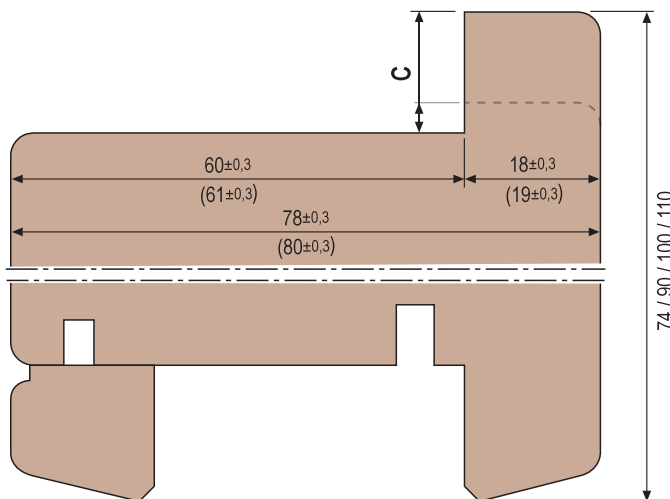
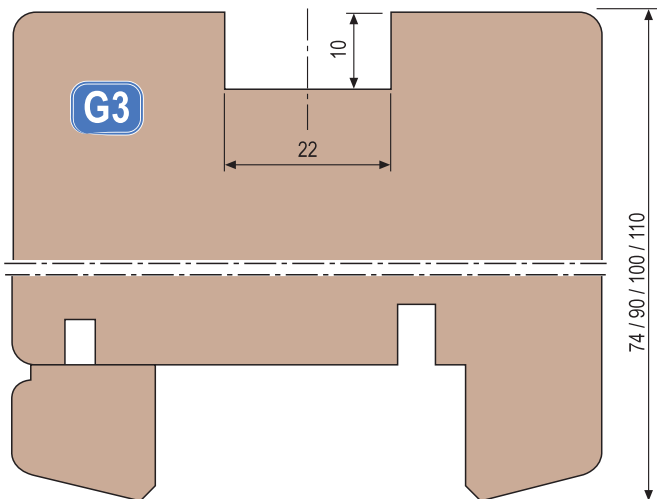

Millings - Vertical section, lower point



It is possible to realise a lower transom height included between 74 and 90 mm; in this case, it is necessary to use XC S-Line carriages with lower transom between 90 and 110 mm. It is possible to use both carriages.

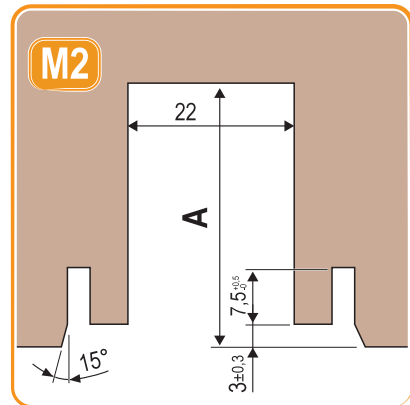
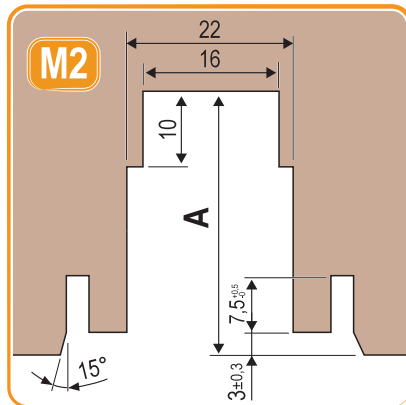
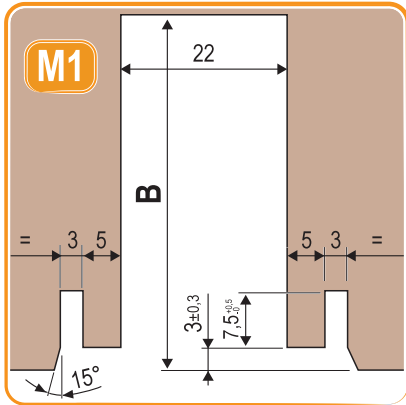
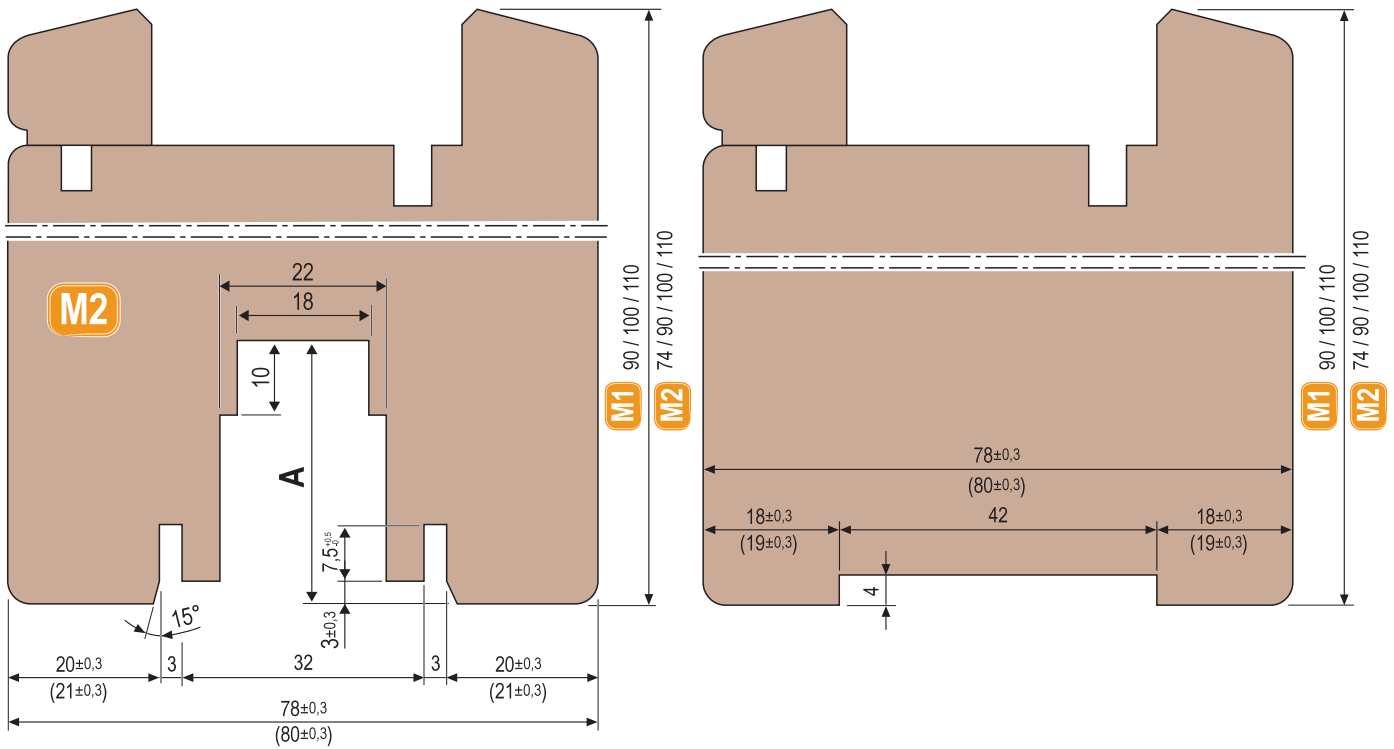

	A	B
	35±0,5	47±0,5
	45±0,5	57±0,5

Millings - Horizontal section, sliding sash

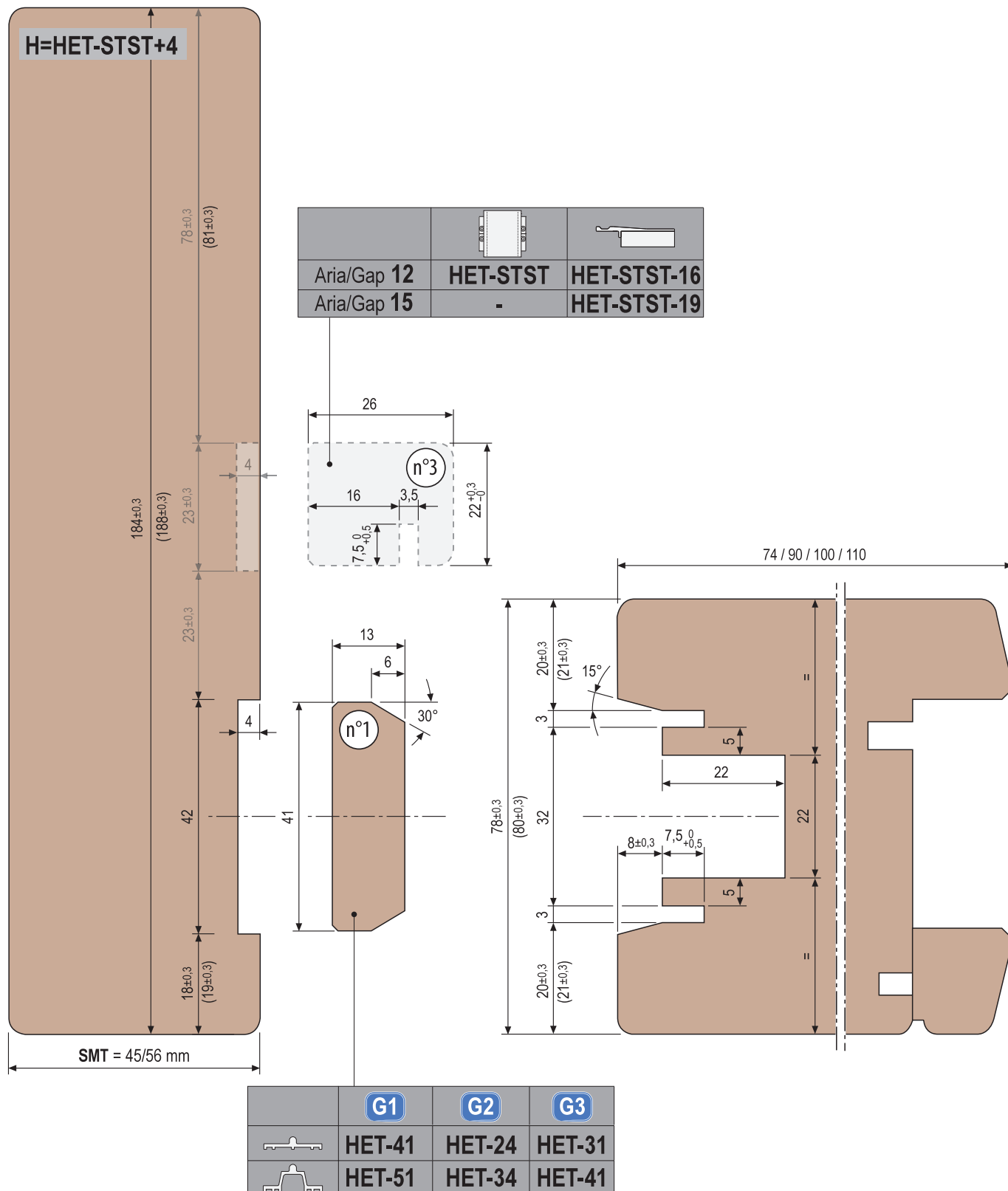

Millings - Horizontal section, fixed sash

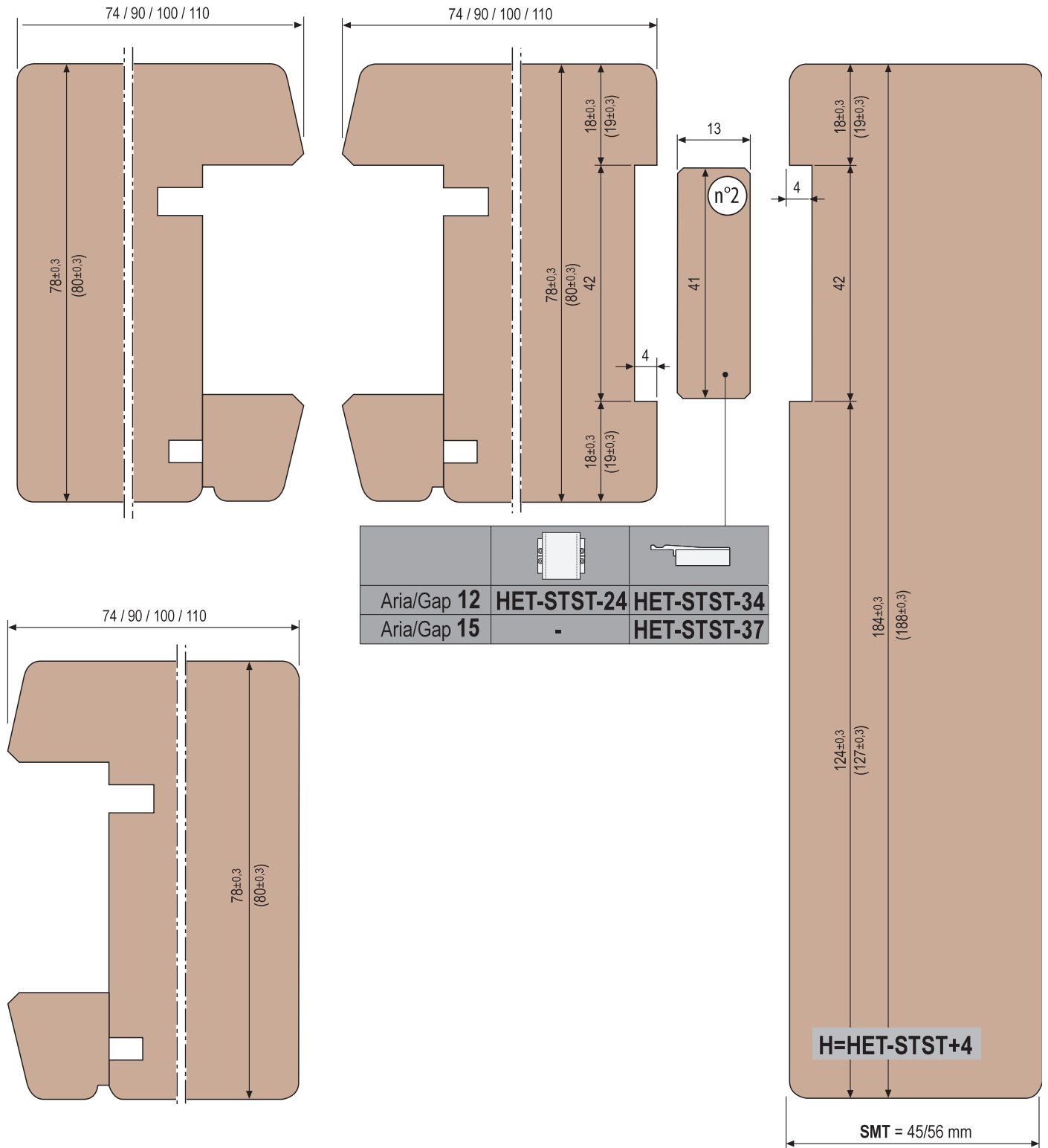

Millings - Horizontal section, central point

Uni-V

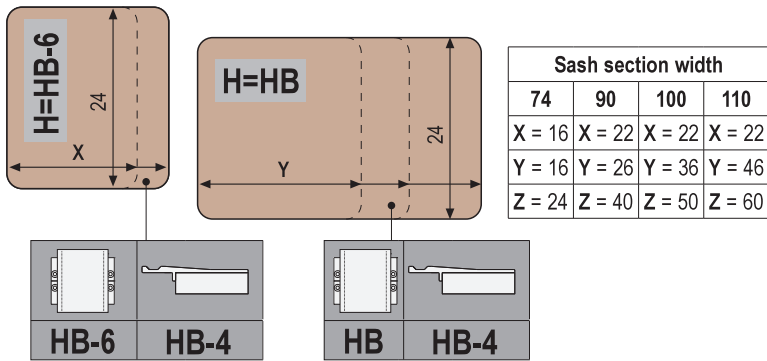

Uni-V Mini

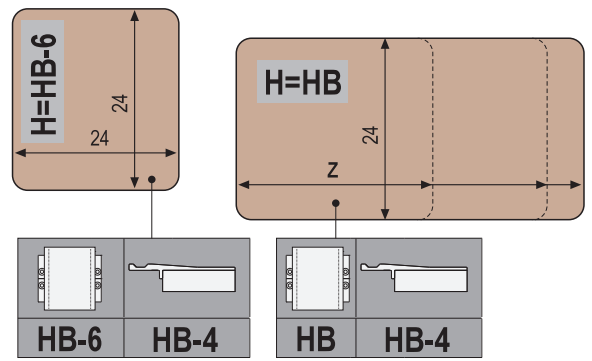

Basic

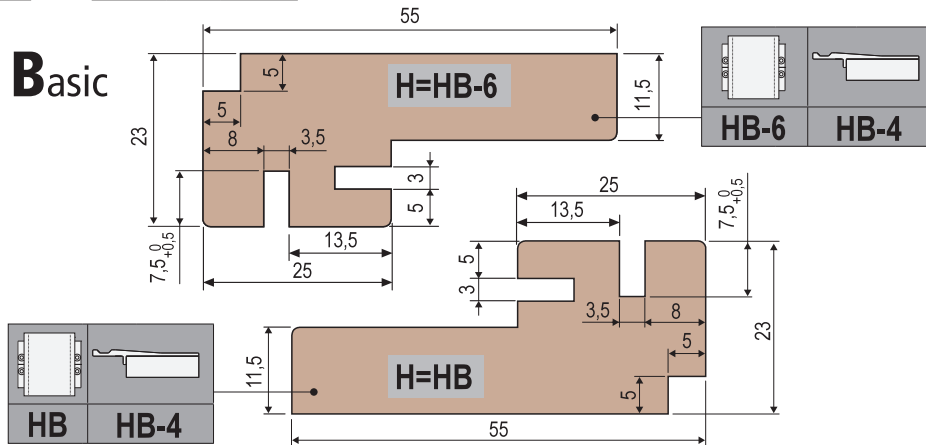

Millings - Central point horizontal section, coaxial sashes

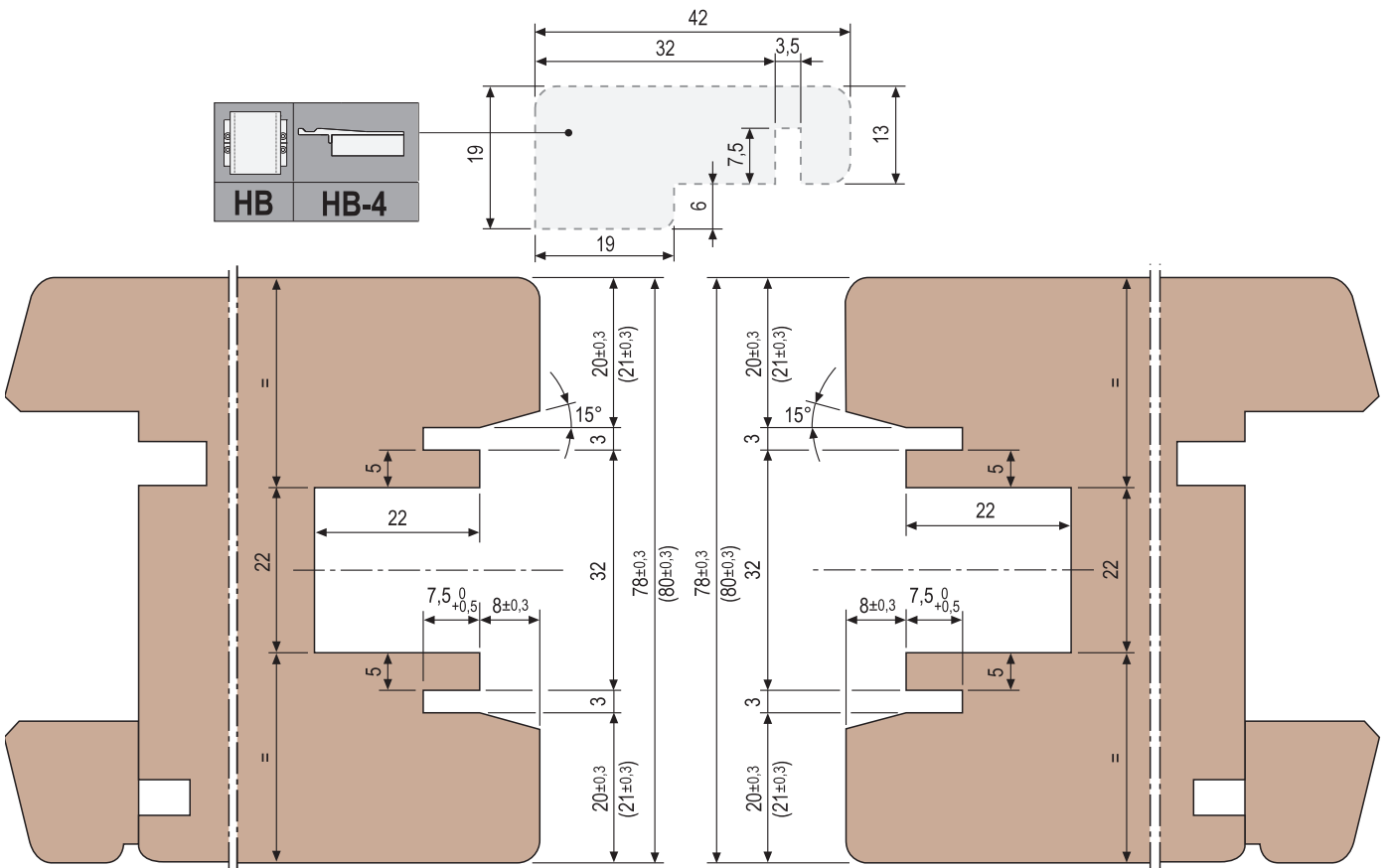

Formulas of components cut

		LAYOUT A			LAYOUT E		
	XC 	HB-94	HB-94	HB-99	HB-94	HB-94	HB-99
	XC S-Line 						
	XC 						
	XC S-Line 						
	XC 	2 (pieces) 80 mm +					
	XC S-Line 	2 (pieces) 80 mm +					
		-	MET-2xSMT-2	-	-	MET-2xSMT-2	-
		-	-	MET-2xSMT-2	-	-	MET-2xSMT-2
		MET-2xSMT-2	-	-	MET-2xSMT-2	-	-
		LB+4			2 (pieces) LB LB+4		
		MET-2xSMT+2			MET-2xSMT		

	HB-10 HB-14										
	HB-4		HET-STST-51	HET-STST-41	HET-STST-34	HET-STST-41	HET-STST-31	HET-STST-24			
	HB-16	HB-14									
			HB-75	HB-28	HB-28	HB-65	HB-18	HB-18			

LAYOUTS B & F

- Sash with only one bottom rail with the possibility for a baseboard.
- Vertical - bottom outside gasket: balloon gasket with vulcanized EPDM corner.
- Inside face EPDM gasket to cover the milled section.
- PVC top gasket with fin.
- Water, air, wind, and soft body impact tests conducted with glass: 44.1/15/33.1 (minimum usable).
- 28 mm distances between the sashEg.
- Layout F constructed with symmetric central point with aluminium pin holder and end caps for closing the openings.

Calculation of dimensions, sliding sashes

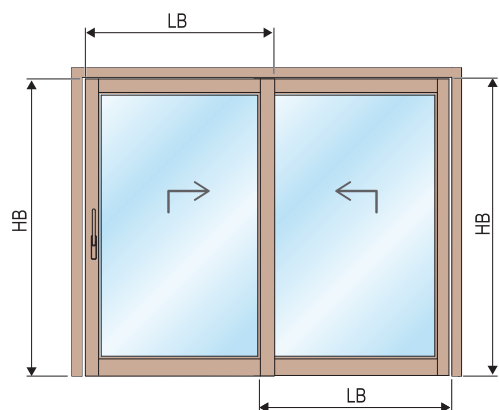

$$HB = HET - (STST + 27 + 4)$$

(Tolerance HB ± 0,5)

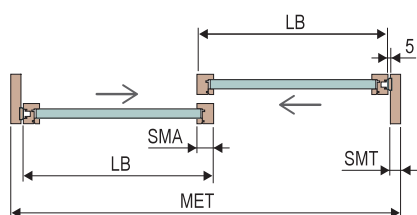
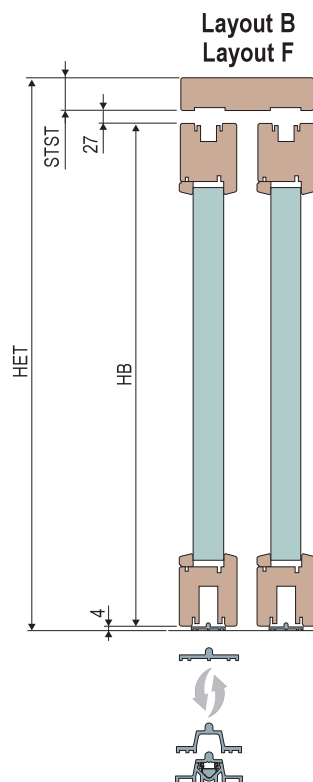

Layout B
2 sliding sashes
 $LB = [MET - 2 \times (SMT + 5)] : 2 + SMA : 2$



Layout F
4 sliding sashes
 $LB = [MET - 15 (2 \times SMT)] : 4 + SMA : 2$



The indications in this section refer to lift-and-slide assemblies with top guide. However, scheme B lift-and-slide assemblies can be constructed with reduced top guide. In this case, refer to the specifications in the section dedicated to schemes A-E.



Since this section of the manual includes only the work and indications that set a B-F scheme apart from an A-E scheme, for omitted information, refer to the section dedicated to A-E schemes.

Hardware diagram with hooks lock

- 1 Hooks lock**
G039EE.03.XX HB=1775-2150 Handle H = 1000
G039EE.04.XX HB=1925-2400 Handle H = 1000
G039EE.05.XX HB=2325-2750 Handle H = 1000
- 2 Additional hook kit - G05008.00.00**
- 3 Microventil. addit. hook kit - G05010.00.00**
- 4 Second sash hooks lock**
GR39EE.03.01 HB=1775-2150 Handle H = 1000
GR39EE.04.01 HB=1925-2400 Handle H = 1000
GR39EE.05.01 HB=2325-2750 Handle H = 1000
- 5 Hooks extension 500 mm - G04600.01.01**
- 6 Covering profile 1000 mm - G04401.02.01**
- 7 Gas spring kit - GMG702.04.00**
- 8 XC basic carriages kit - G04104.00.00**
- 9 XC supp. carriages kit - G04108.00.00**
- 10 XC S-Line carriages kit - G04109.00.00**
- 11 XC S-Line supp. carriages kit - G04110.00.00**
- 12 Carriages connecting rod**
G04601.00.01 L=1000 G04601.00.03 L=1800
G04601.00.02 L=1400 G04601.00.04 L=2700
- 13 Handle fastening plate**
G05371.M5.00 hole M5
G05371.M6.00 hole M6
- 14 Anti-burglar plate kit - G05004.00.00**
- 15 Sensors**
G05006.00.86 grey
G05006.00.93 black
G05003.00.00 clip
- 16 Lateral locking profile for hooks lock**
G01359.03.XX GR3 Predisposit. 2 hooks
G01359.04.XX GR4 Predisposit. 2 hooks
G01359.05.XX GR5 Predisposit. 2 hooks
G01359.13.XX GR3 Predisposit. 3 hooks
G01359.14.XX GR4 Predisposit. 3 hooks
G01359.15.XX GR5 Predisposit. 3 hooks
G01359.23.XX GR3 Predisposit. signal system
G01359.24.XX GR4 Predisposit. signal system
G01359.25.XX GR5 Predisposit. signal system
- 17 Extens. for lock. prof. for hooks lock**
G01360.01.XX L=500
- 18 Coax. sashes lock. prof. for hooks lock + caps**
G01373.13.XX L=2075 HB=1775-2150 with strik. hooks
G01373.14.XX L=2325 HB=1925-2400 with strik. hooks
G01373.15.XX L=2750 HB=2325-2750 with strik. hooks
- 19 Coax. sashes lock. prof. extens. for hooks, 500 mm**
G01364.01.XX with strik. hook
- 20 Striker for lock hook - G06201.00.XX**
- 21 Strik. for lock hook with signal system - G06203.00.XX**
- 22 Lower thermal pad - G01400.07.93**
- 23 Upper guide**
G00734.01.XX L=3000
G00734.02.XX L=4000
G00734.03.XX L=6000
- 24 Shaped cap for upper guide (F)**
- 25 2 mm thick. (F)**
- 26 Thermal cap for lock (F)**
- 27 Rear upper covering cap (F)**
- 28 Rear low. covering cap (F)**
- 29 Door stop**
G00204.00.91 white G00204.00.93 black
G00204.00.86 grey
- 30 Low rail**
G00738.01.XX L=3000
G00738.02.XX L=4000
G00738.03.XX L=6000
- 31 Profile for up. and low. "C" track**
G01739.01.XX L=3000 G01739.03.XX L=5000
G01739.02.XX L=4000 G01739.04.XX L=6000
- 32 Snap-in rail for "C" track**
G02739.01.XX L=3000 G02739.03.XX L=5000
G02739.02.XX L=4000 G02739.04.XX L=6000
- 33 High rail kit + snap-in profile**
G01104.01.XX L=3000 G01104.03.XX L=5000
G01104.02.XX L=4000 G01104.04.XX L=6000
- 34 High rail and sliding prof. fast. clip - G01110.01.00**
- 35 High rail**
G00739.01.XX L=3000
G00739.02.XX L=4000
G00739.03.XX L=6000
- 36 Uni-V central point kit**
G02208.25.KK L=2500
G02208.31.KK L=3100
G02208.40.KK L=4000
- 37 Uni-V central point caps kit**
G01610.DX.93 right
G01610.SX.93 left
- 38 Uni-V Mini central point kit**
G02211.25.KK L=2500 G02211.40.KK L=4000
G02211.31.KK L=3100
- 39 Uni-V Mini central point caps kit**
G01623.DX.93 right G01623.SX.93 left
- 40 External side gasket (balloon)**
G020DX.09.93 - G020SX.09.93 L1500 x H2500
G02000.08.93 L3000 x H3000
- 41 PVC upper flexible gasket**
G00733.02.01 L=40
G00733.02.02 L=200
- 42 Flexible gasket for central point**
G00733.04.01 L=40
G00733.04.02 L=200
- 43 Brush for decompression chamber**
G02002.16.00 L=1600 G02002.31.00 L=3100
G02002.25.00 L=2500 G02002.31.20 L=3100 (tube)
G02002.25.20 L=2500 (tube)
- 44 Brush up. thermal pad - G00728.12.15**
- 45 Thick. for brush pad - G00728.27.00**
- 46 Milling low cap for high rail**
G00811.57.00 high rail
G00811.47.00 low rail
- 47 Thermal pad for high guide**
G01413.27.0B 120 mm
- 48 EPDM gasket - G01416.17.15**
- 49 XC anti-derailed device - G01611.02.00**
- 50 Rod guide - G05102.00.00**
- 51 S-Line anti-derailed device - G01611.01.00**
- 52 S-Line rod guide - G05104.00.00**
- 53 Handle access. kit for 78&92 thick.**
G05390.00.00 screws M5
G05390.01.00 screws M6
- 54 Connecting kit jamb - transom - G00728.00.23**
- 55 Handle**

(F) Caps kit for universal upper guide
G00203.01.JJ high rail
G00203.02.JJ low rail

XX = 01 alum. silver 02 alu. electrocolour KK = 01 silver 93 black
EE = 27 backset 27,5 37 backset 37,5

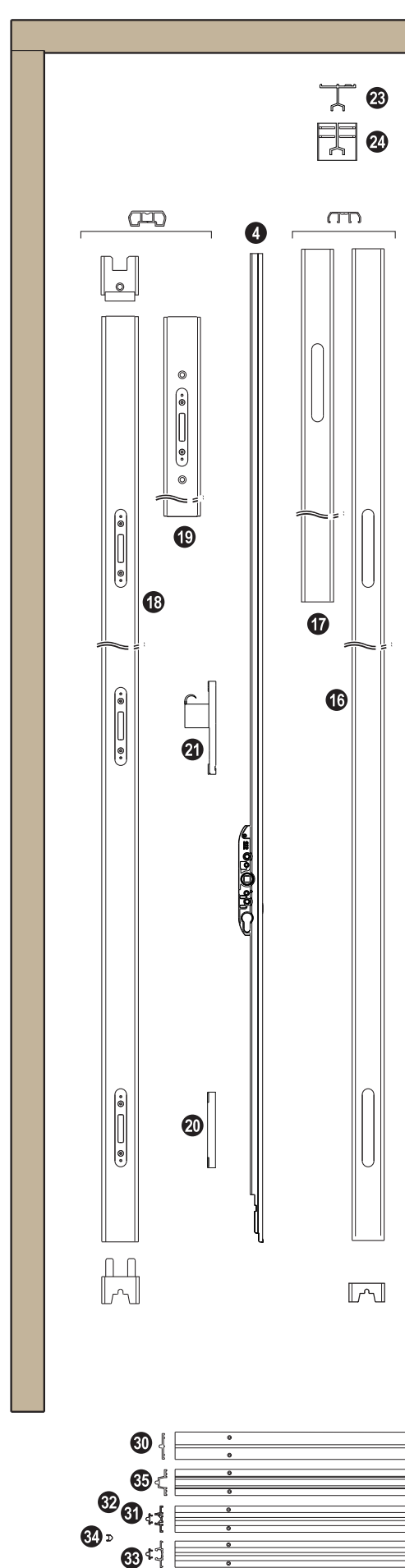

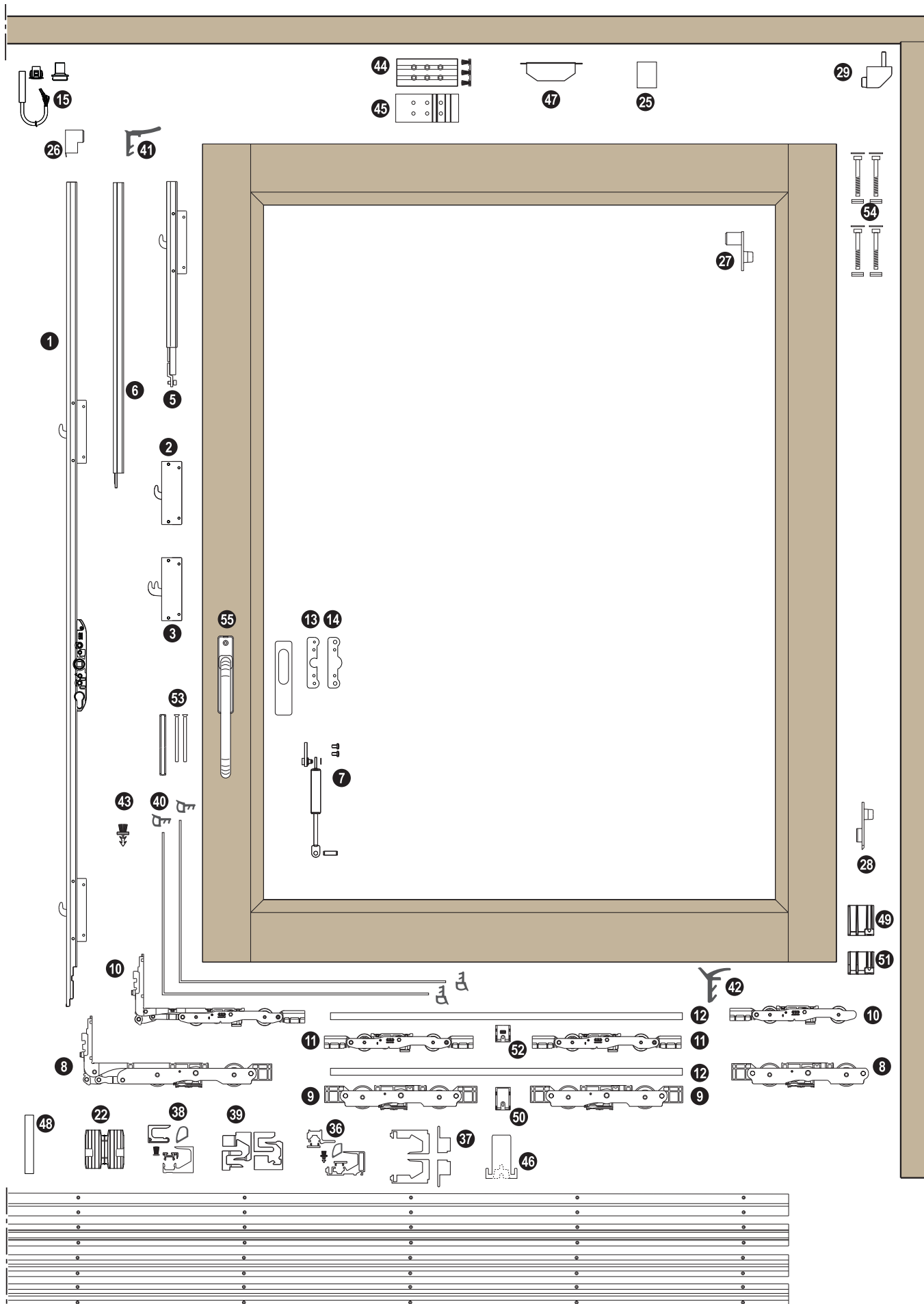

Hardware diagram with pins lock

- 1** Pins lock
 - G040EE.01.XX Handle H = 400 HB=800-1200
 - G040EE.02.XX Handle H = 400 HB=1170-1800
 - G040EE.03.XX Handle H = 1000 HB=1770-2150
 - G040EE.04.XX Handle H = 1000 HB=1920-2400
 - G040EE.05.XX Handle H = 1000 HB=2401-2750
- 2** Pins extension 500 mm - G04401.01.01
- 3** Covering profile 1000 mm - G04401.02.01
- 4** Gas spring kit - GMG702.04.00
- 5** XC basic carriages kit - G04104.00.00
- 6** XC suppl. carriages kit - G04108.00.00
- 7** XC S-Line carriages kit - G04109.00.00
- 8** XC S-Line supp. carriages kit - G04110.00.00
- 9** Carriages connecting rod
 - G04601.00.01 L=1000 G04601.00.03 L=1800
 - G04601.00.02 L=1400 G04601.00.04 L=2700
- 10** Handle fastening plate
 - G05371.M5.00 hole M5
 - G05371.M6.00 hole M6
- 11** Anti-burglar plate kit - G05004.00.00
- 12** Sensors
 - G05006.00.86 grey
 - G05006.00.93 black
 - G05003.00.00 Clip
- 13** Pin holder profile for lateral point
 - G01341.00.XX L=1800 HB=800-1800
 - G01341.01.XX L=2900 HB=1770-2900
 - G01341.02.XX L=2900 HB=2401-2900
- 14** Locking profile for coaxial sashes + caps
 - G01361.01.XX L=1125 HB=810-1200
 - G01361.02.XX L=1725 HB=1175-1800
 - G01361.03.XX L=2075 HB=1775-2150 with caps
 - G01361.04.XX L=2325 HB=1925-2400
 - G01361.05.XX L=2750 HB=2325-2750
 - G01340.01.XX L=1125 HB=810-1200
 - G01340.02.XX L=1725 HB=1175-1800 with caps and ventilat. pin
 - G01340.03.XX L=2075 HB=1775-2150
 - G01340.04.XX L=2325 HB=1925-2400
 - G01340.05.XX L=2750 HB=2325-2750
- 15** Coax. sashes lock. prof. extens. for pins, 500 mm
G01361.97.XX
- 16** Coax. sashes lock. prof. extens. for pins, 1000 mm
G01757.00.XX
- 17** Pin
 - G40728.00.03 for closing
 - G04902.01.00 for ventilation
- 18** Lower thermal pad - G01400.07.93
- 19** Upper guide
 - G00734.01.XX L=3000
 - G00734.02.XX L=4000
 - G00734.03.XX L=6000
- 20** Shaped cap for upper guide (F)
- 21** 2 mm thick. (F)
- 22** Terminal cap for lock (F)
- 23** Rear upper covering cap (F)
- 24** Rear lower covering cap (F)
- 25** Door stop
 - G00204.00.91 white G00204.00.93 black
 - G00204.00.86 grey
- 26** Low rail
 - G00738.01.XX L=3000
 - G00738.02.XX L=4000
 - G00738.03.XX L=6000
- 27** Profile for up. and low. "C" track
 - G01739.01.XX L=3000 G01739.03.XX L=5000
 - G01739.02.XX L=4000 G01739.04.XX L=6000
- 28** Snap-in rail for "C" track
 - G02739.01.XX L=3000 G02739.03.XX L=5000
 - G02739.02.XX L=4000 G02739.04.XX L=6000
- 29** High rail kit + snap-in profile
 - G01104.01.XX L=3000 G01104.03.XX L=5000
 - G01104.02.XX L=4000 G01104.04.XX L=6000
- 30** High rail fastening kit and slid. prof. - G01110.01.00
- 31** High rail
 - G00739.01.XX L=3000
 - G00739.02.XX L=4000
 - G00739.03.XX L=6000
- 32** Uni-V central point kit
 - G02208.25.KK L=2500
 - G02208.31.KK L=3100
 - G02208.40.KK L=4000
- 33** Uni-V central point caps kit
 - G01610.DX.93 right
 - G01610.SX.93 left
- 34** Uni-V Mini central point kit
 - G02211.25.KK L=2500 G02211.40.KK L=4000
 - G02211.31.KK L=3100
- 35** Uni-V Mini central point caps kit
 - G01623.DX.93 right G01623.SX.93 left
- 36** External side gasket (balloon)
 - G020DX.09.93 - G020SX.09.93 L1500 x H2500
 - G02000.08.93 L3000 x H3000
- 37** PVC upper flexible gasket
 - G00733.02.01 L=40
 - G00733.02.02 L=200
- 38** Flexible gasket for central point
 - G00733.04.01 L=40
 - G00733.04.02 L=200
- 39** Brush for decompression chamber
 - G02002.16.00 L=1600 G02002.31.00 L=3100
 - G02002.25.00 L=2500 G02002.31.20 L=3100 (tube)
 - G02002.25.20 L=2500 (tube)
- 40** Brush upper terminal pad - G00728.12.15
- 41** Thick. for brush pad - G00728.27.00
- 42** Milling lower pad for high rail
 - G00811.57.00 high rail
 - G00811.47.00 low rail
- 43** Thermal pad for high guide
G01413.27.0B 120 mm
- 44** EPDM gasket - G01416.17.00
- 45** XC anti-derailed device - G01611.02.00
- 46** Rod guide - G05102.00.00
- 47** S-Line anti-derailed device - G01611.01.00
- 48** S-Line rod guide - G05104.00.00
- 49** Handle accessories kit for 78&92 thick.
 - G05390.00.00 screws M5
 - G05390.01.00 screws M6
- 50** Connecting kit jamb - transom - G00728.00.23
- 51** Handle

(F) Caps kit for universal upper guide

- G00203.01.JJ high rail
- G00203.02.JJ low rail

XX = 01 alum. silver KK = 01 silver
 02 alu. electrocolour 93 black

EE = 27 backset 27,5
 37 backset 37,5

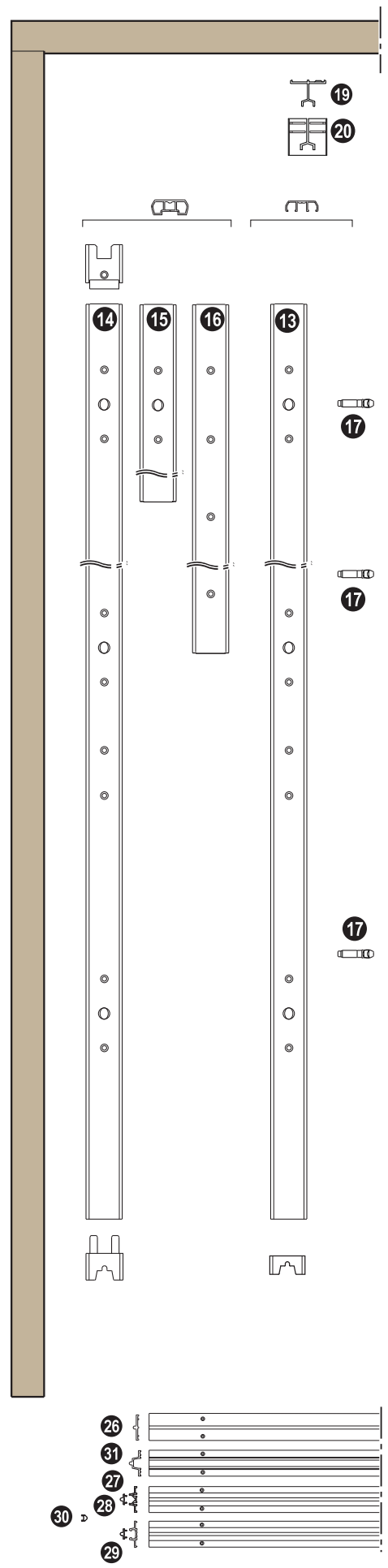

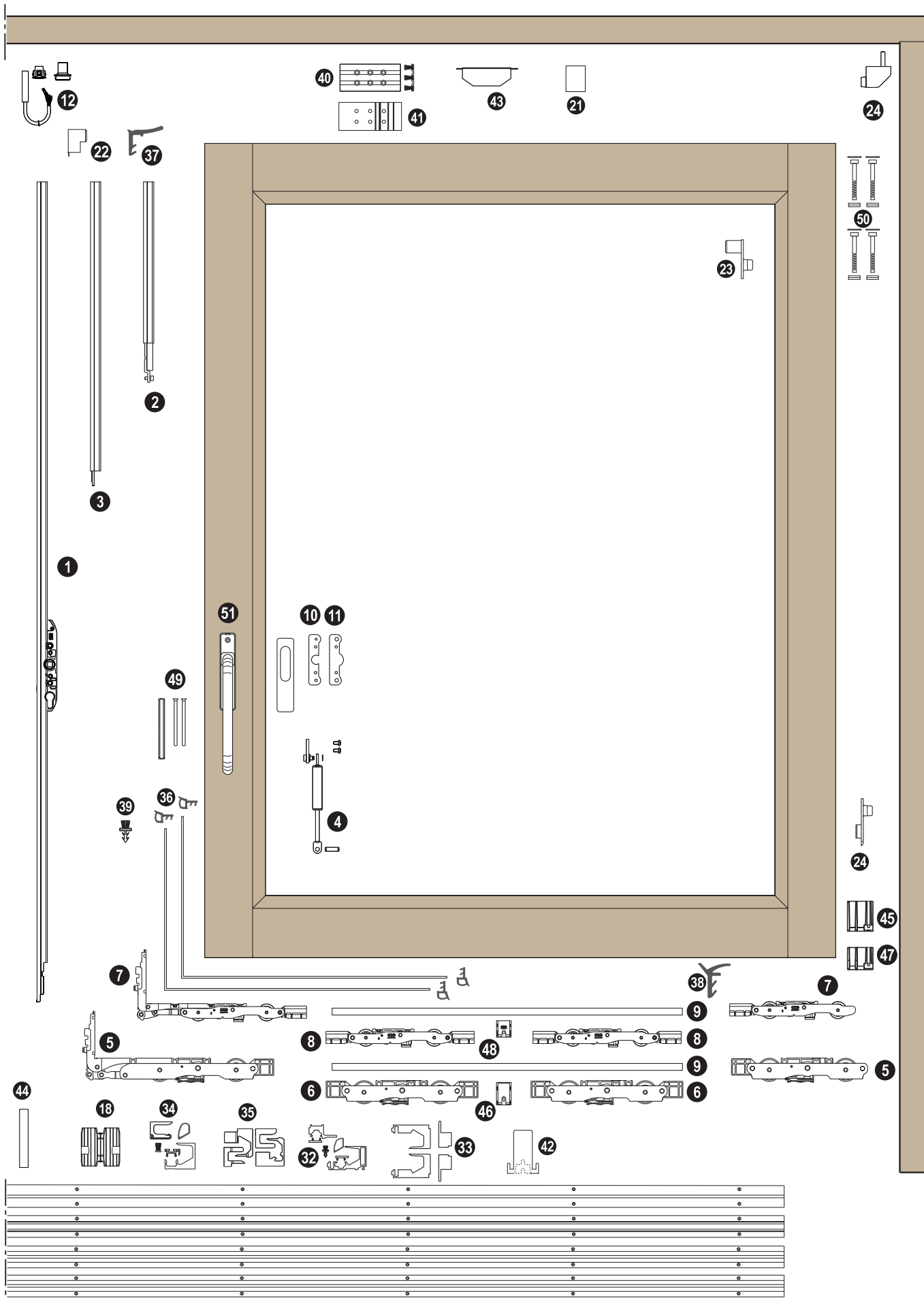

Horizontal section

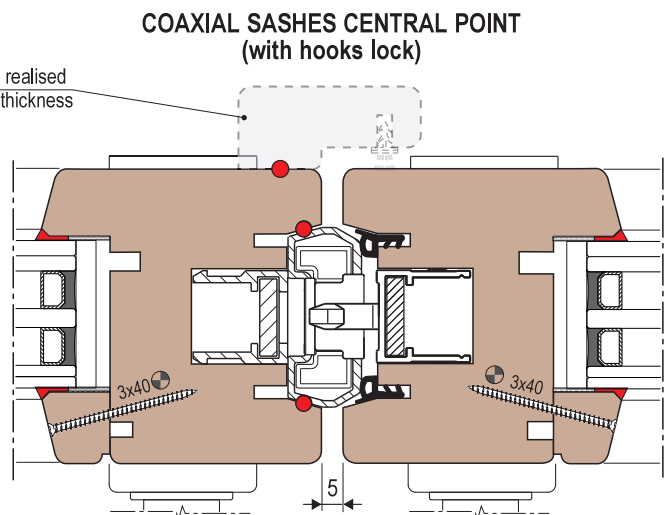
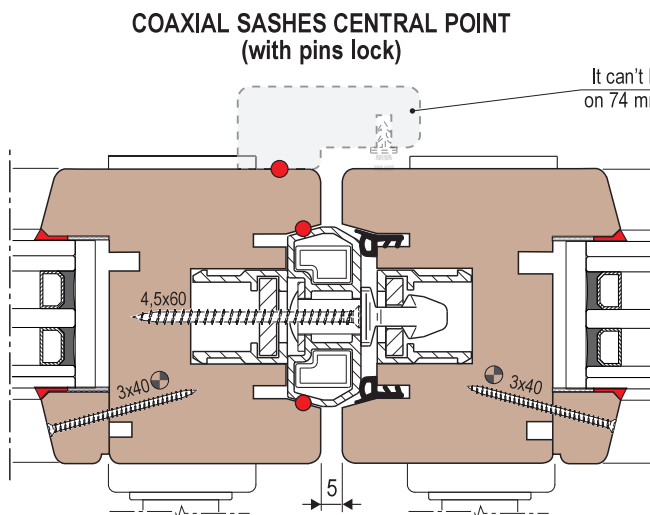
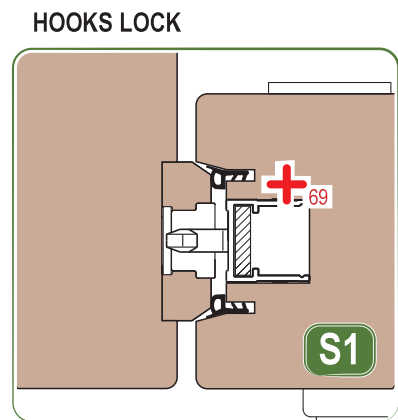
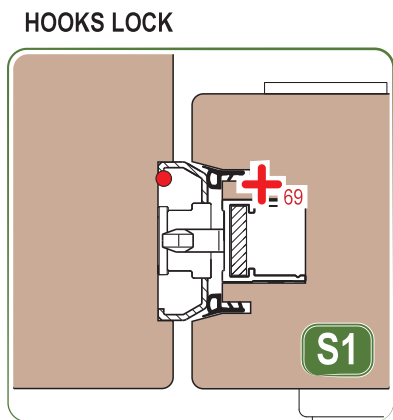
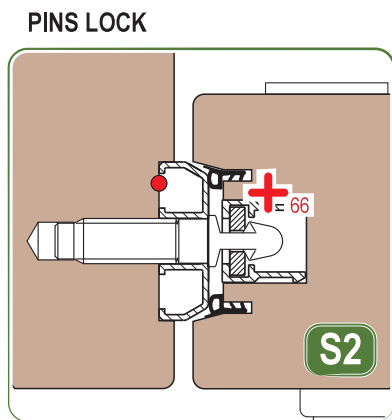
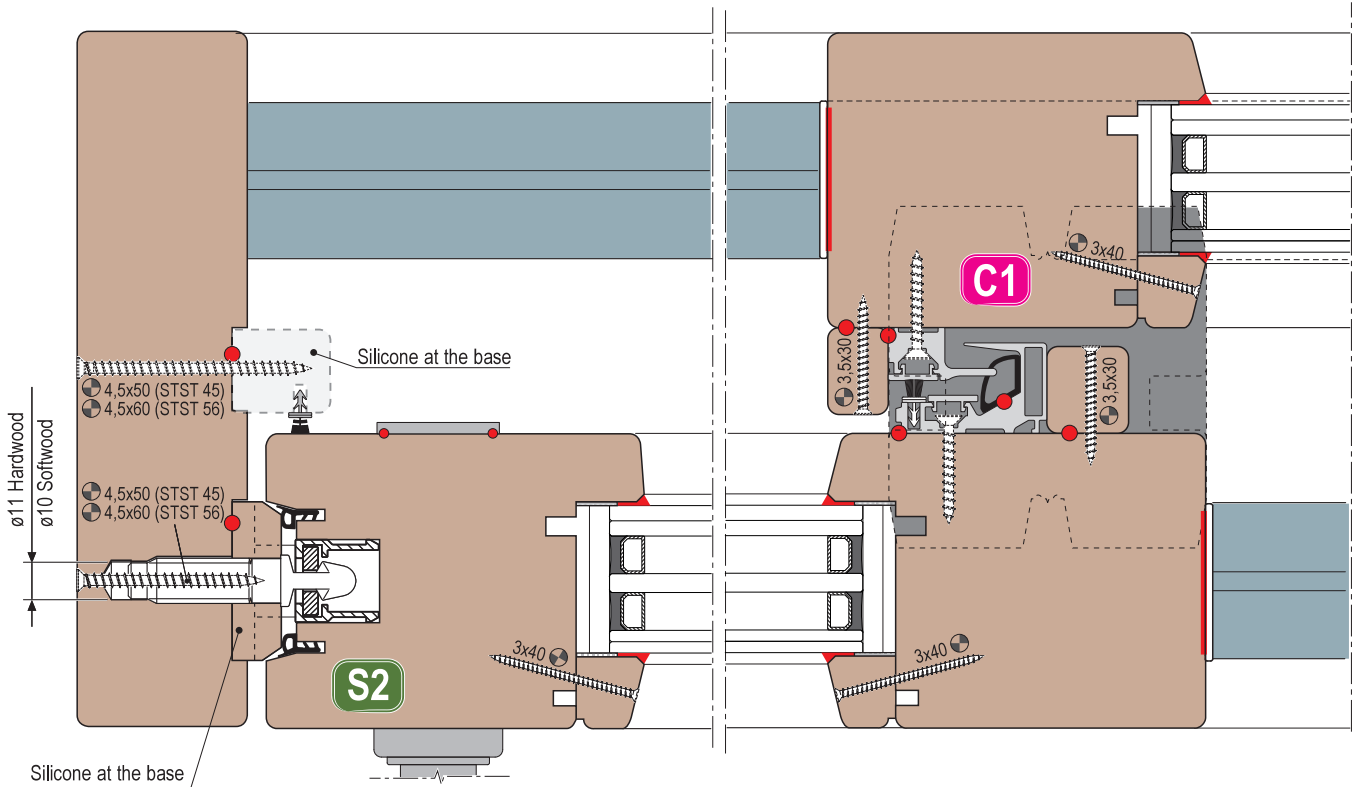

It can't be realised on 74 mm thickness

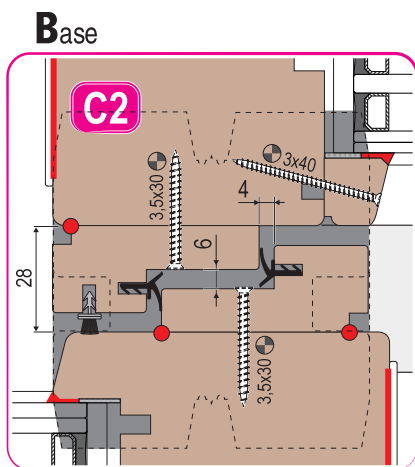
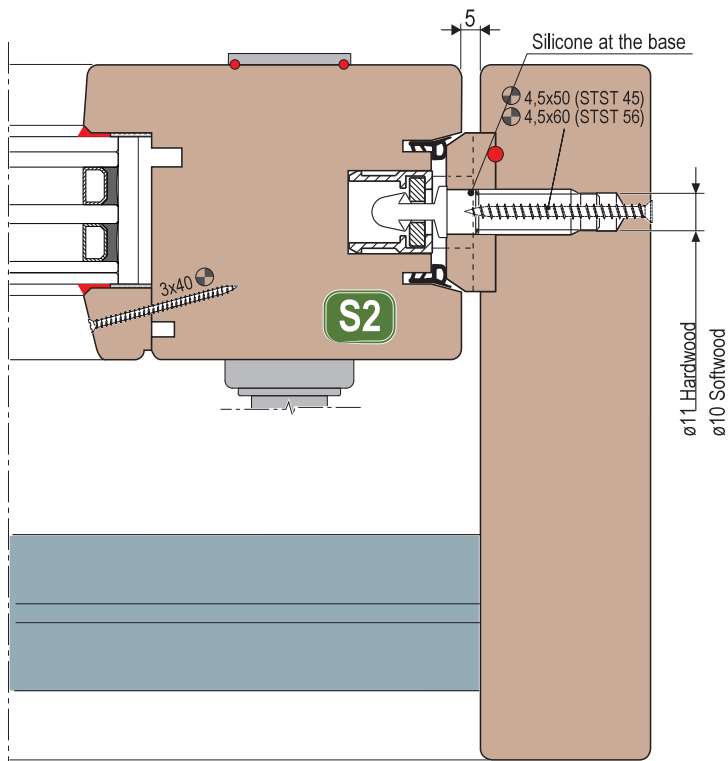

Align the pad to the external sash jamb

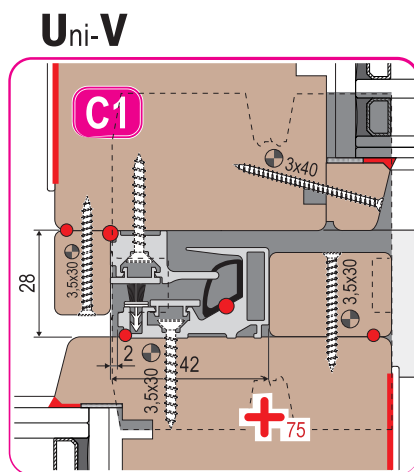

Position the pad as indicated

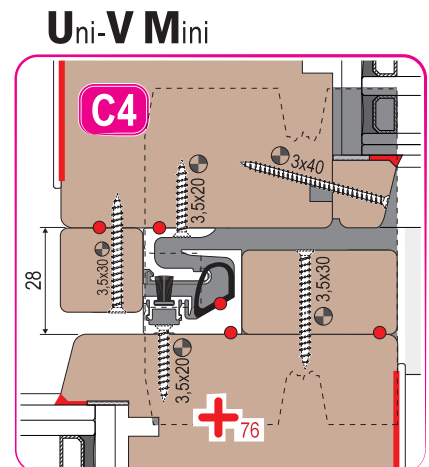

Position the pad as indicated

	Uni-V	Uni-V Mini	Base
Sash section width 74	X = 26	X = 26	
Sash section width 90	X = 10	X = 10	-
Sash section width 100	X = 6	-	-
Sash section width 110	-	-	-

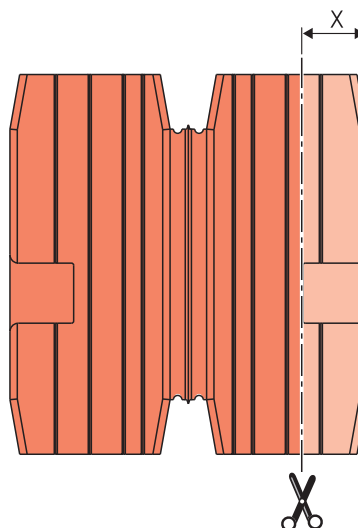

Jams and listels building details

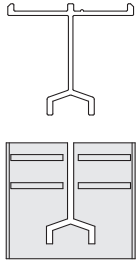

CAP CUT DETAIL

LISTEL N.1 WITH LOW RAIL

LISTEL N.1 WITH HIGH RAIL

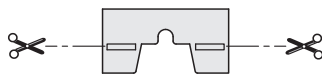
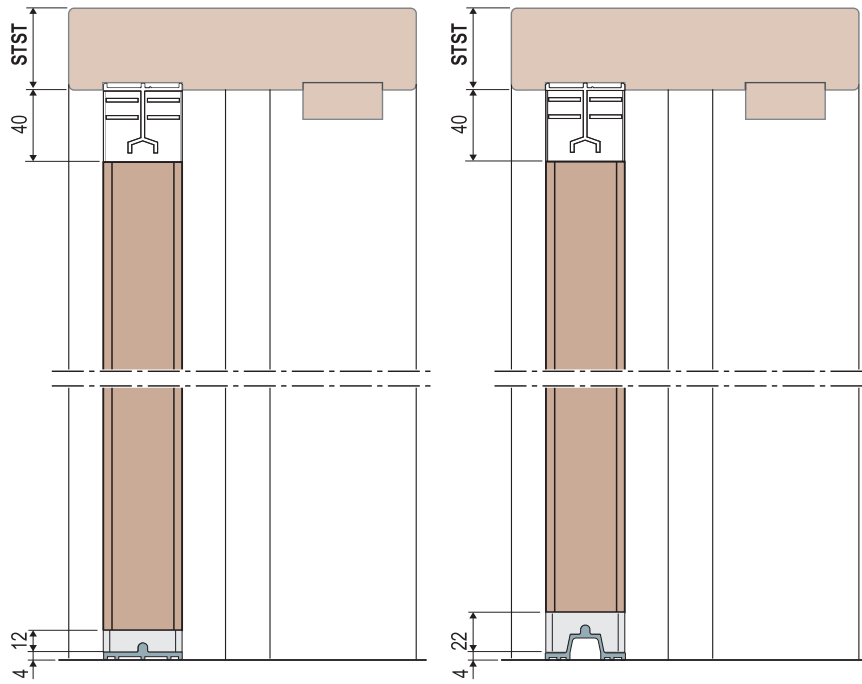

CAP CUT DETAIL
(only with low rail)

Vertical section, upper point

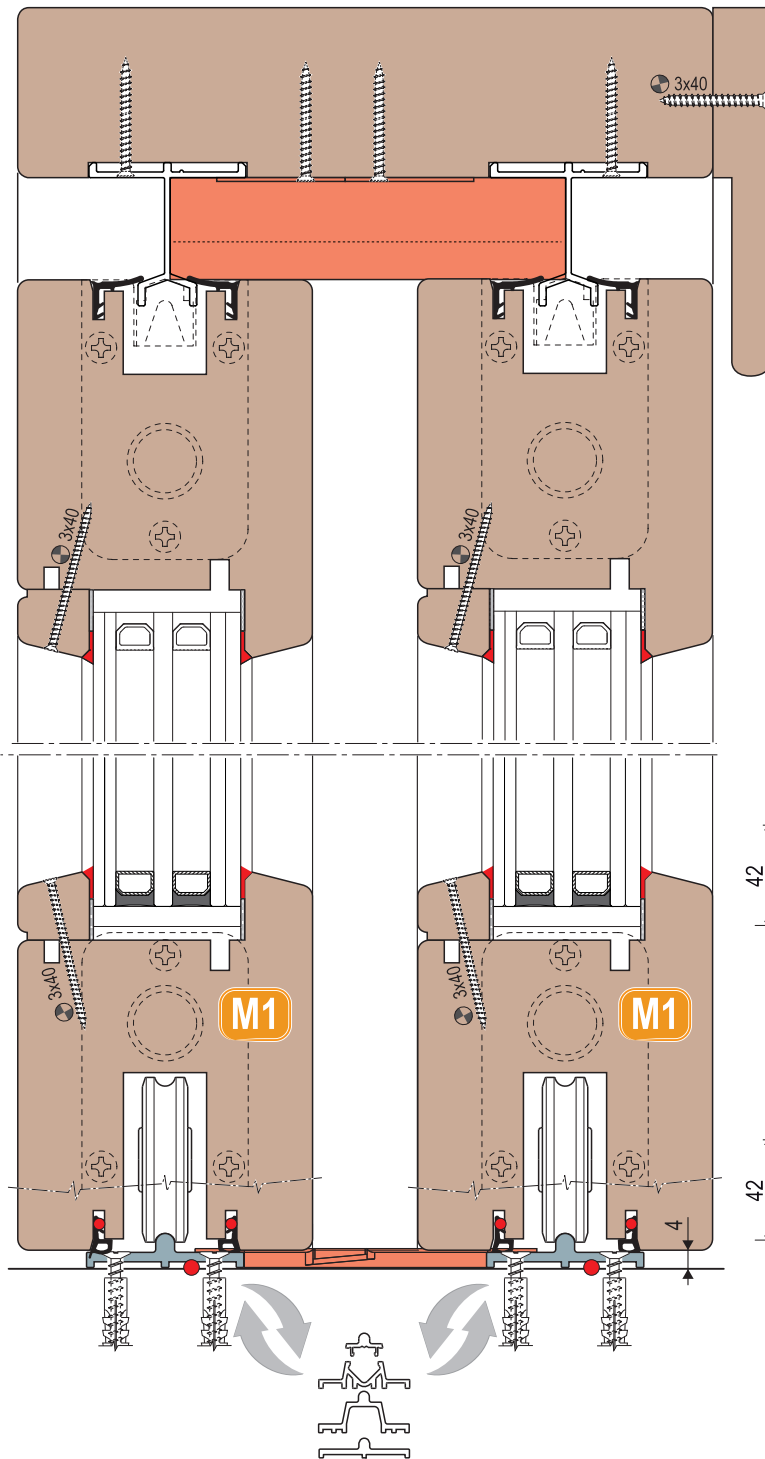

TOP PAD POSITIONING
(the brush strip with adapter is an alternative solution to the sponge pad)

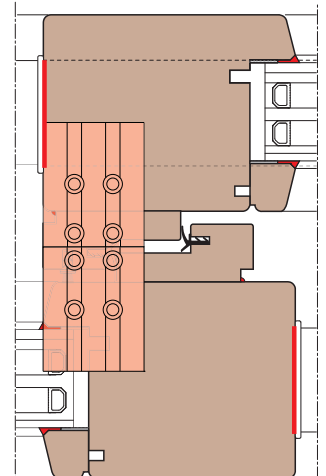
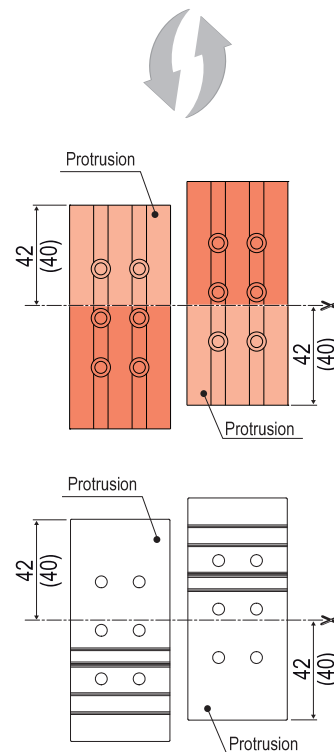
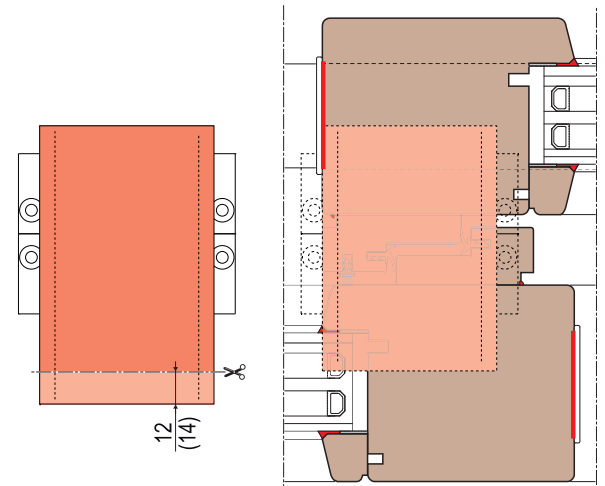

XC S-LINE CARRIAGES
(SEAT 16 mm)

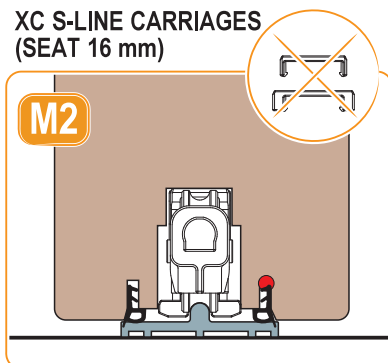

XC S-LINE CARRIAGES
(SEAT 18 mm)

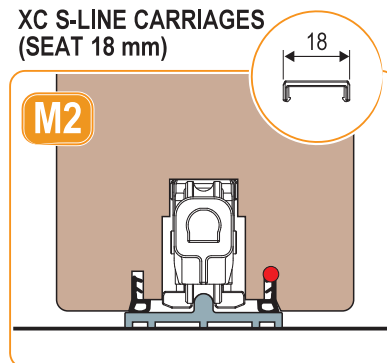

XC S-LINE CARRIAGES
(SEAT 22 mm)

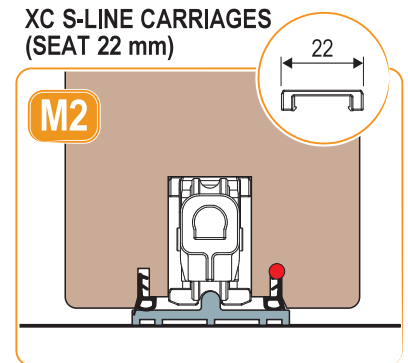

Wood millings: frame jamb horizontal section

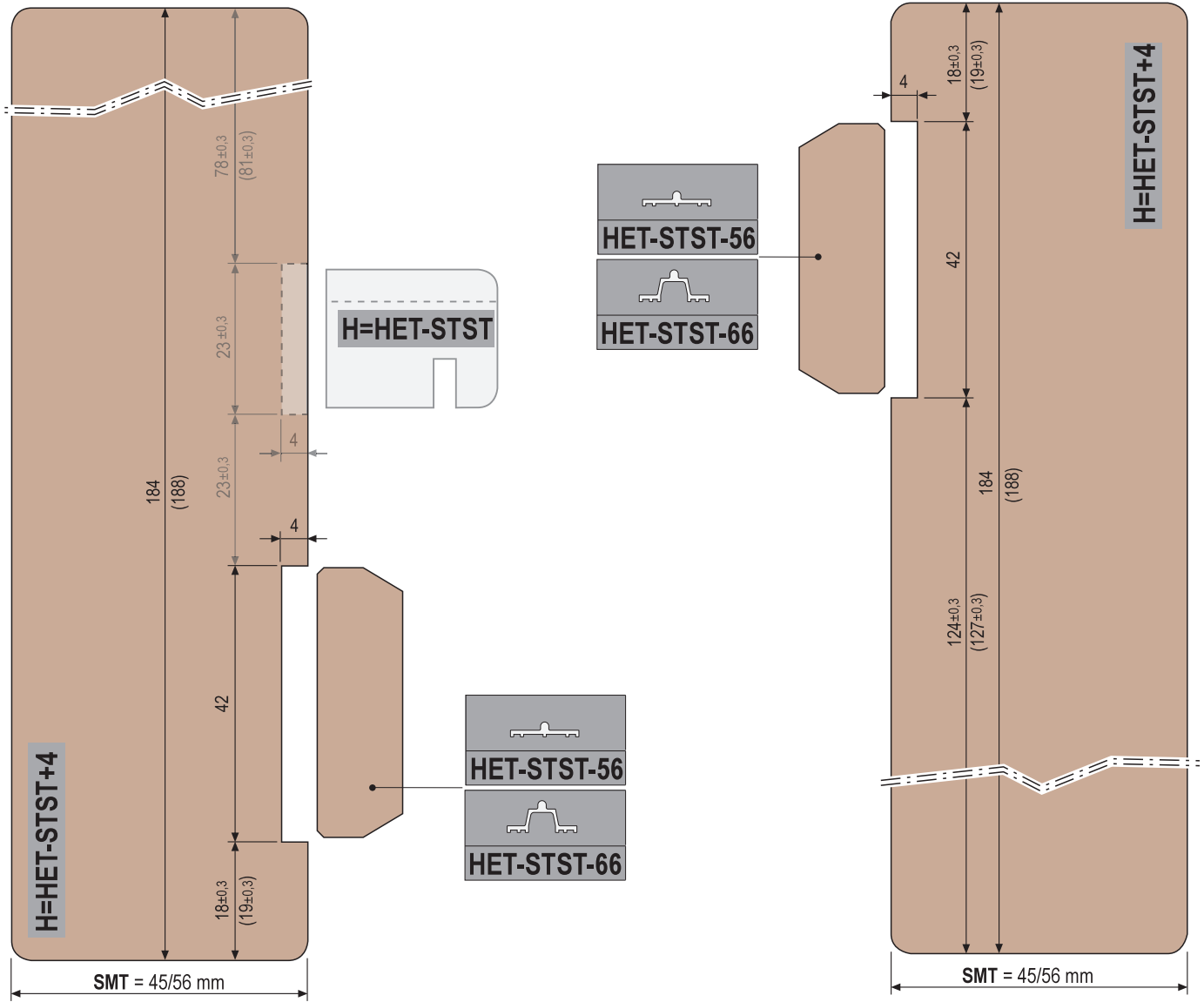

Wood millings: central point horizontal section

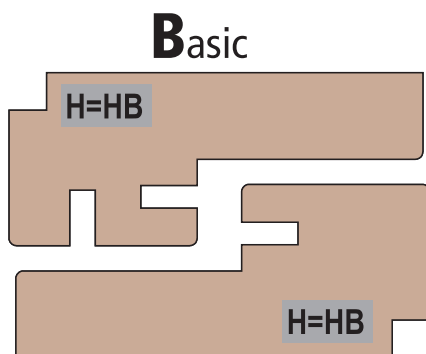
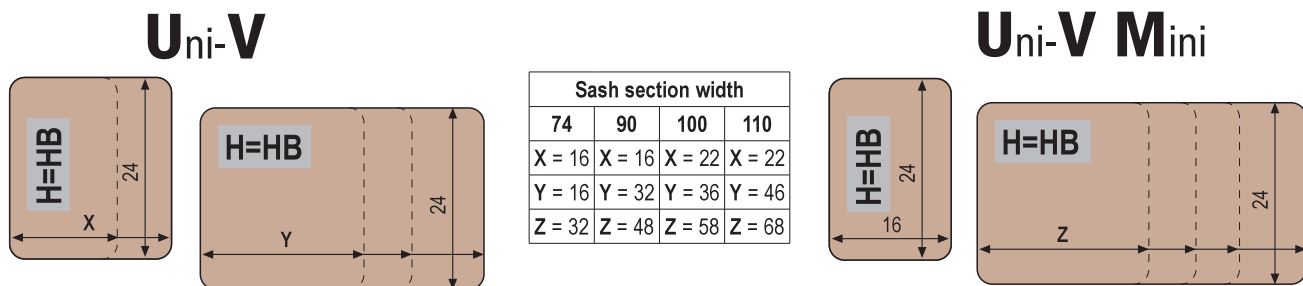

Wood millings: upper frame transom vertical section

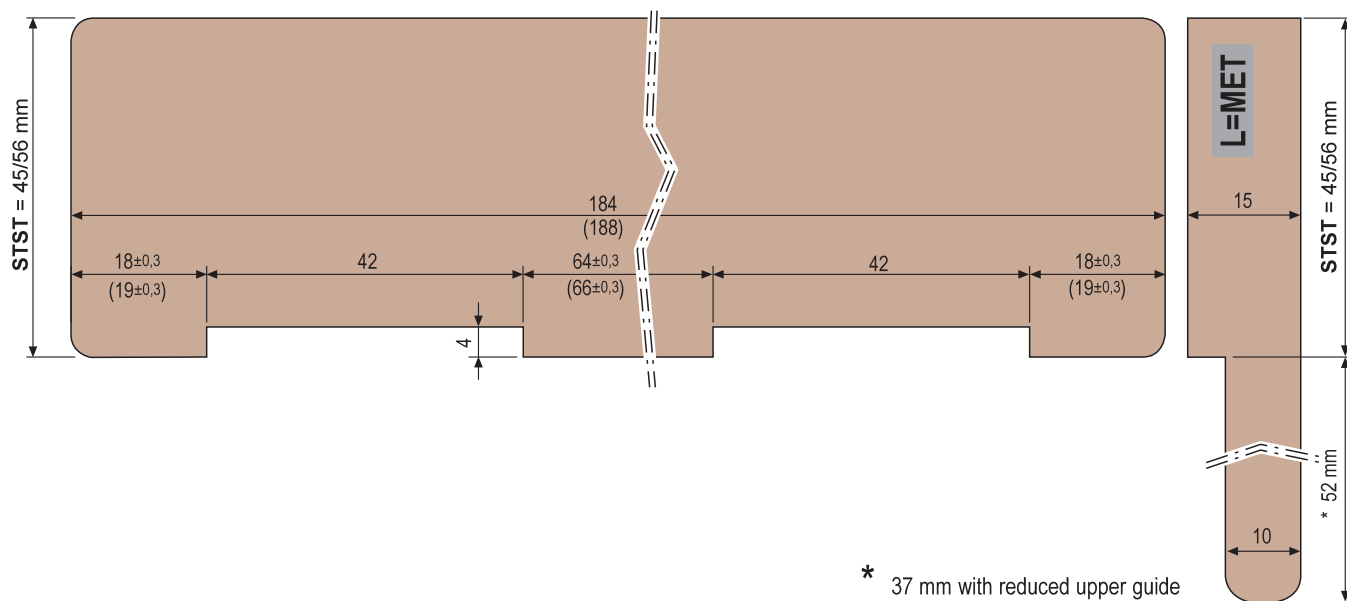

Building details, layouts B & F

TOP LOCKING PROFILE



The top locking profile is not used. A top insulating pad positioned between the top guides is used.

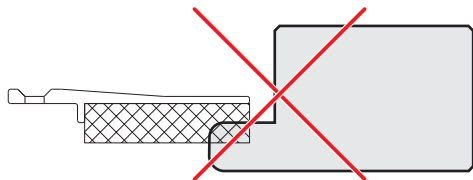

BRUSH LISTELS FOR DECOMPRESSION CHAMBER



The brush holder listel in the side point (layout B) is facultative.



BOTTOM PAD



Do not cut the excess part of the bottom pad.

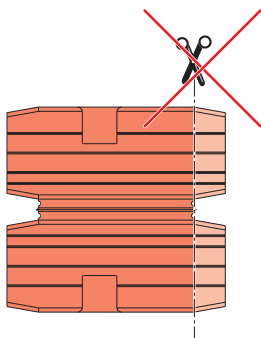

REAR LOWER PAD CUT



Cut the exceeding part of the lower pad according to seat dimension of XC S-LINE carriage.

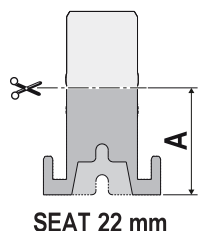
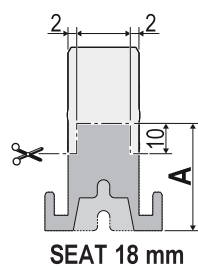
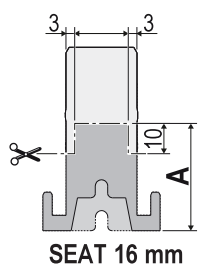

	A
	35
	45

POSITION OF ANTI-DERAIL BLOCKS



Install 2 blocks on each central sash.
Install 1 block on each side sash.

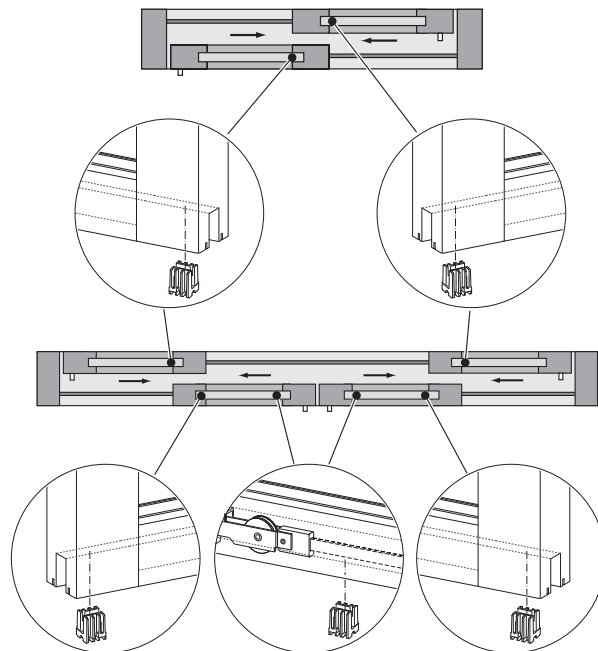

POSITION OF BOTTOM REAR SEALING PAD



Position the bottom rear sealing pad between the cap and the anti-derail block.

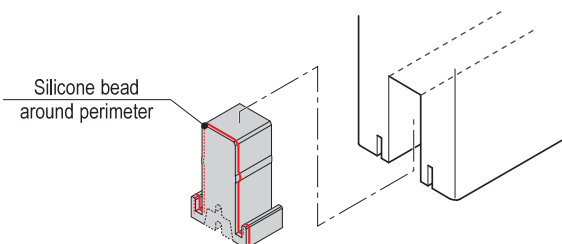
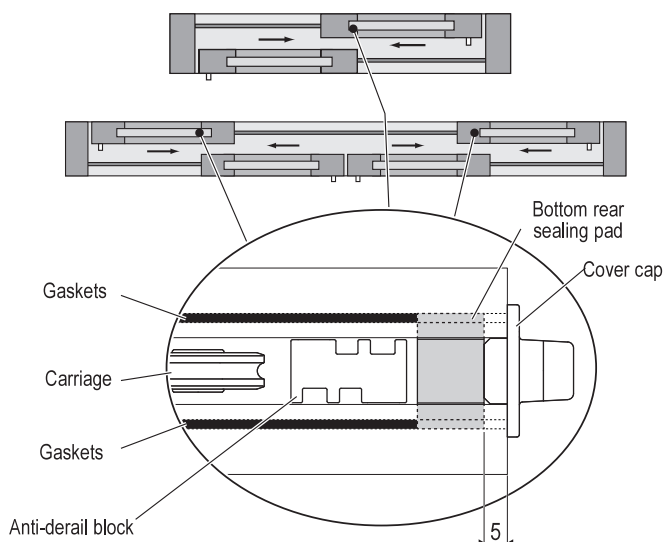

Formulas of components cut

		LAYOUT B	LAYOUT F
		HB-94	HB-94
		2 (pieces) 80 mm +	
		2 (pieces) 80 mm +	
		2 (pieces) MET-2xSMT+2	2 (pieces) MET-2xSMT
		2 (pieces) MET-2xSMT-2	2 (pieces) MET-2xSMT-2

	HB-10
	HB-4
	HB-10

LAYOUTS A & E, LAYOUTS B & F - ASSEMBLY OPERATIONS

Positioning of central listels on the sashes

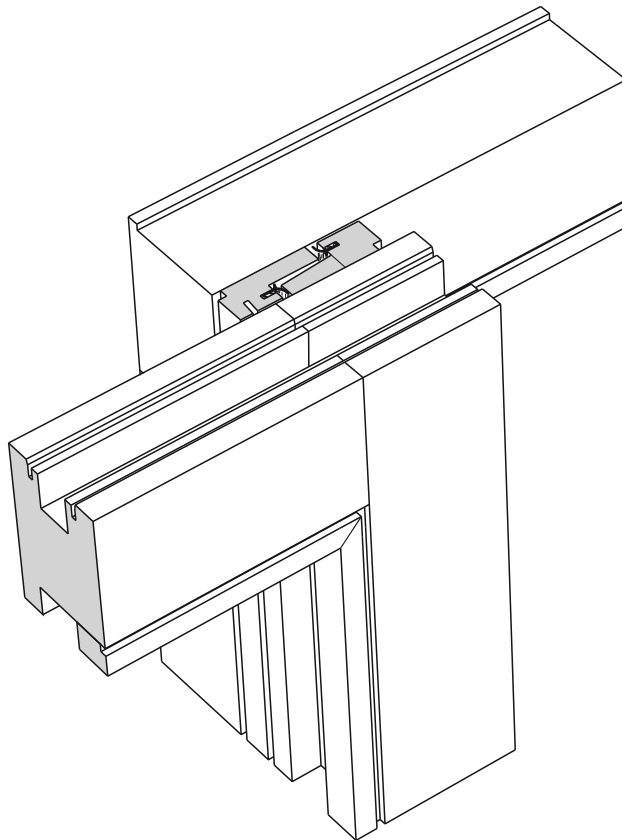

**Top part of stiles
shaping detail**
(only with top insulation pad)

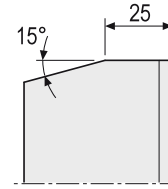

Shaping of sliding sash listel

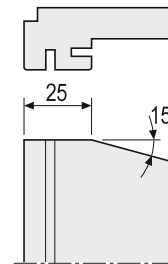

Shaping of sliding sash listel
(only for layout B and F)

Pad application on central jambs

Before installing the lower pads,
make a silicone beadaround
perimeter as indicated.

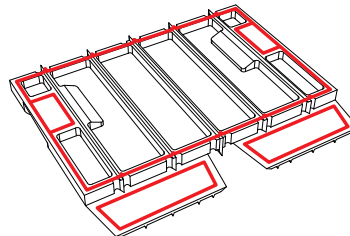

Lock holes realisation

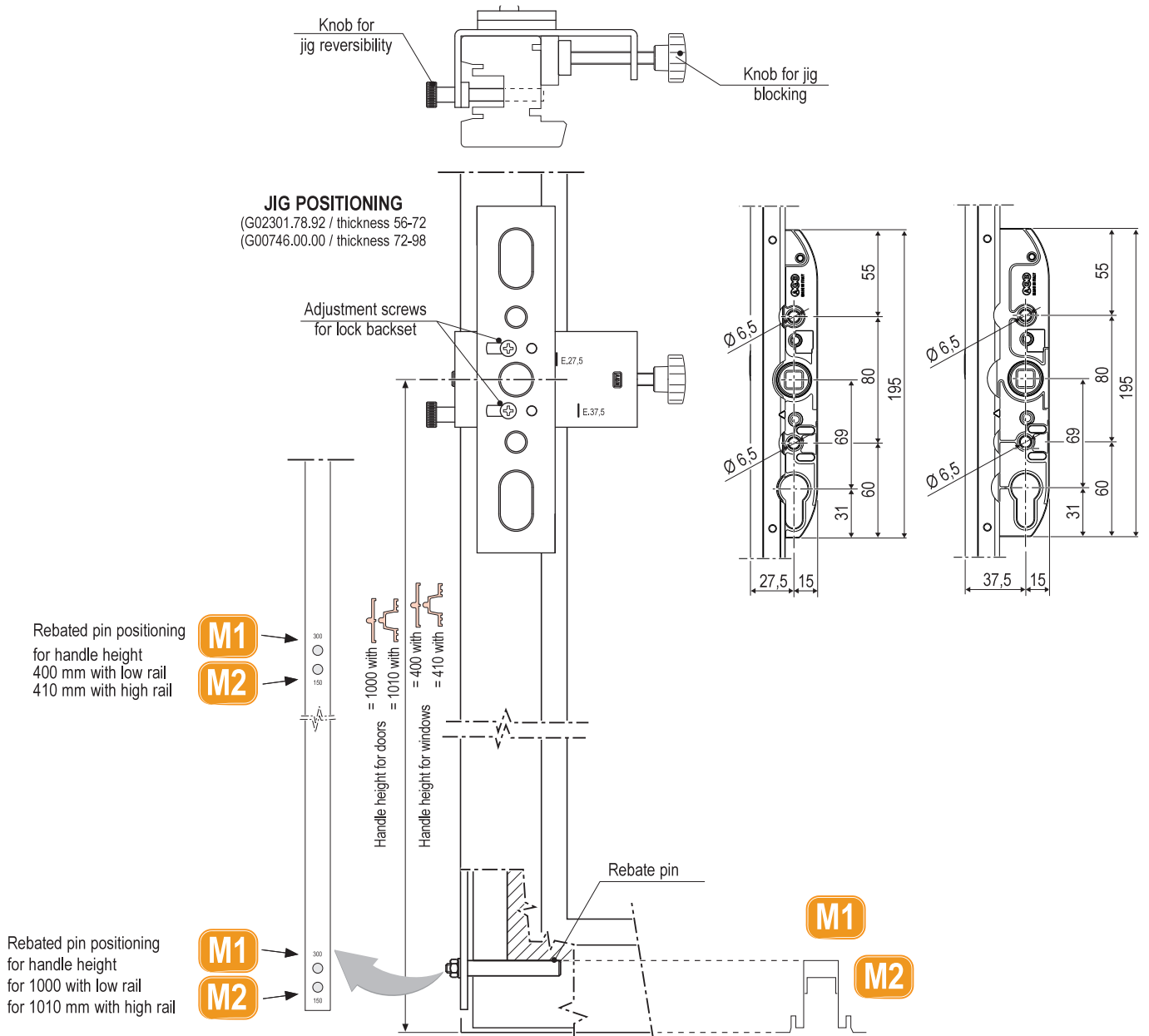

DRILLING FOR HANDLE

VIEW "A" - INT. SIDE

DRILLING FOR EXTERNAL PULL HANDLE

VIEW "B"

Backset	X
27	27,5
37	37,5

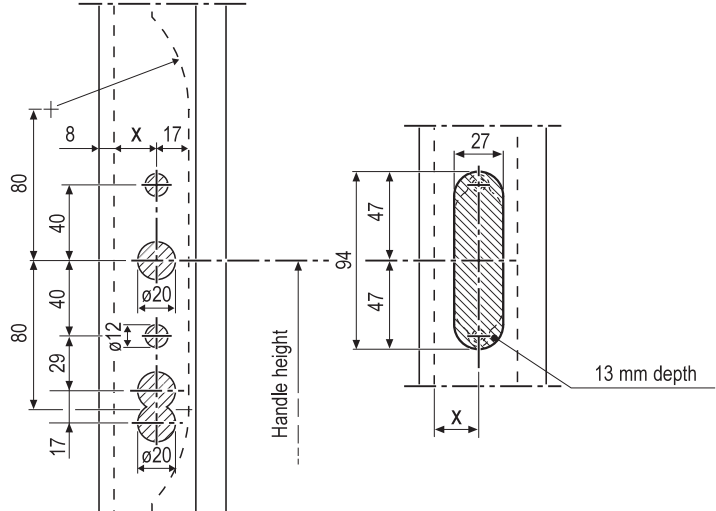
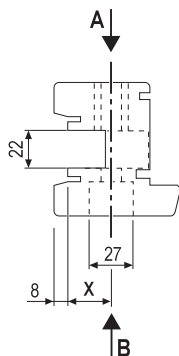

Accessories for single sash configuration with guide 22x22

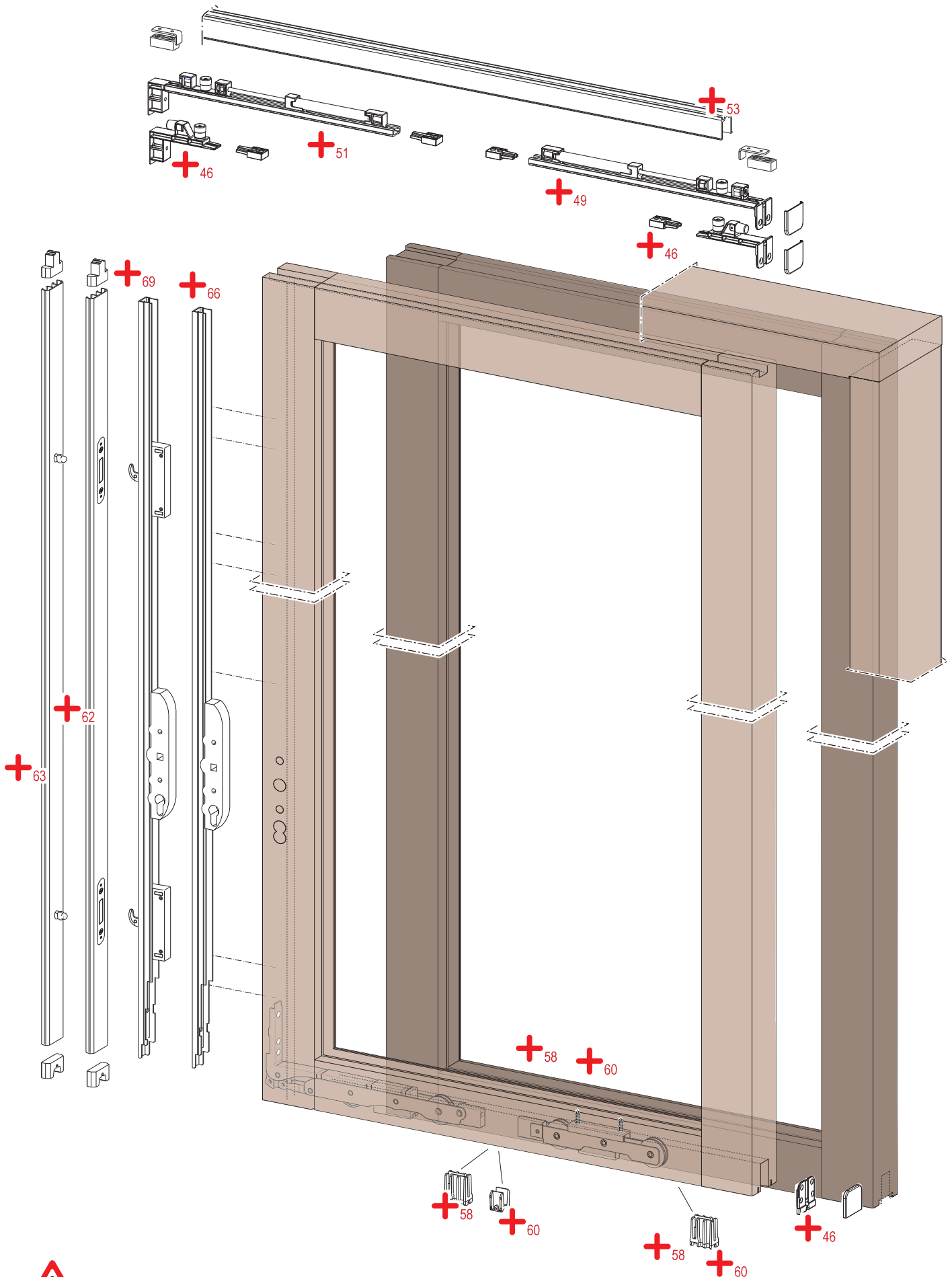

Carriages and locks in this picture are indicative only.

Accessories for single sash configuration with guide 22x13

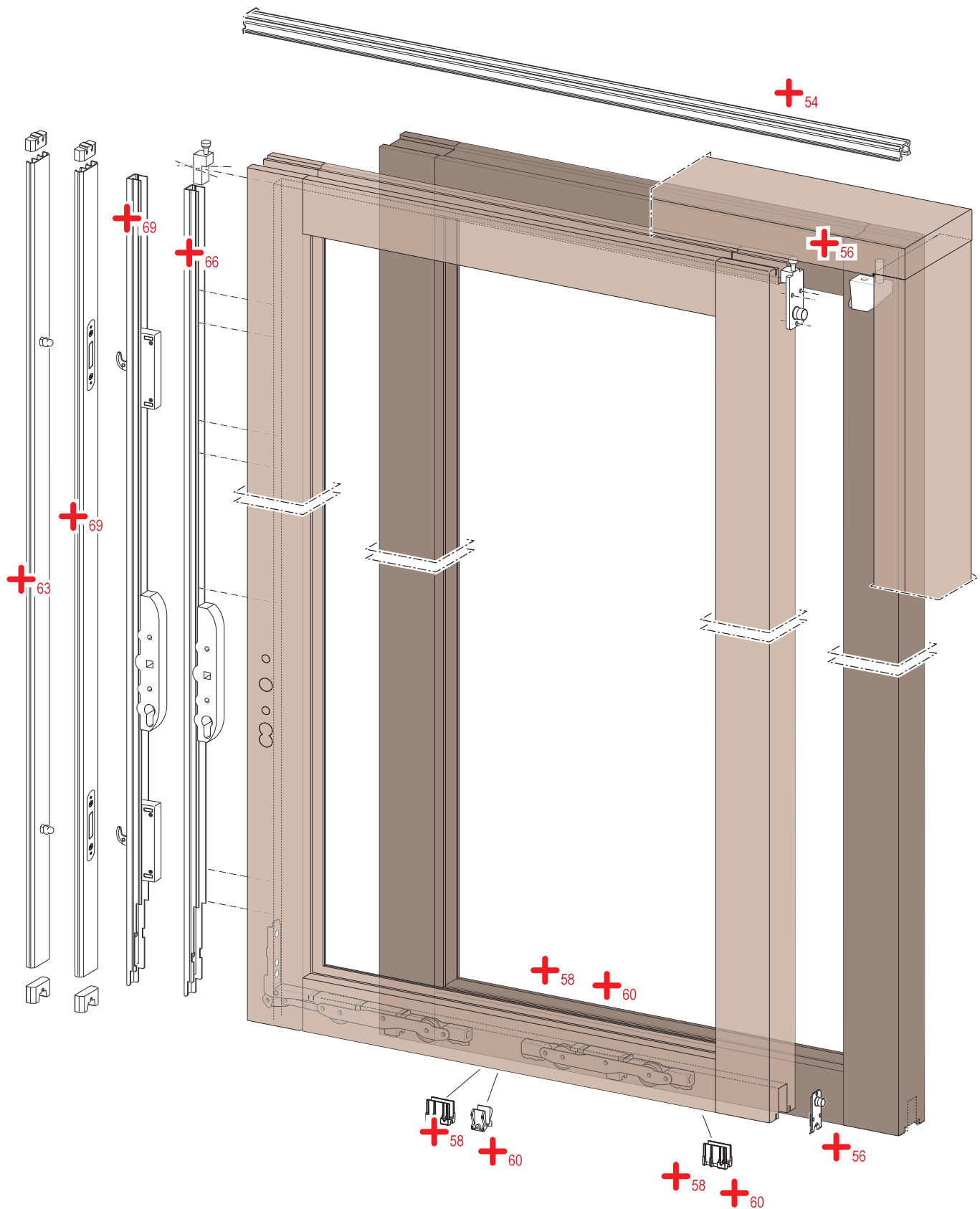

Carriages and locks in this picture are indicative only.

Accessories for coaxial sashes configuration with guide 22x13

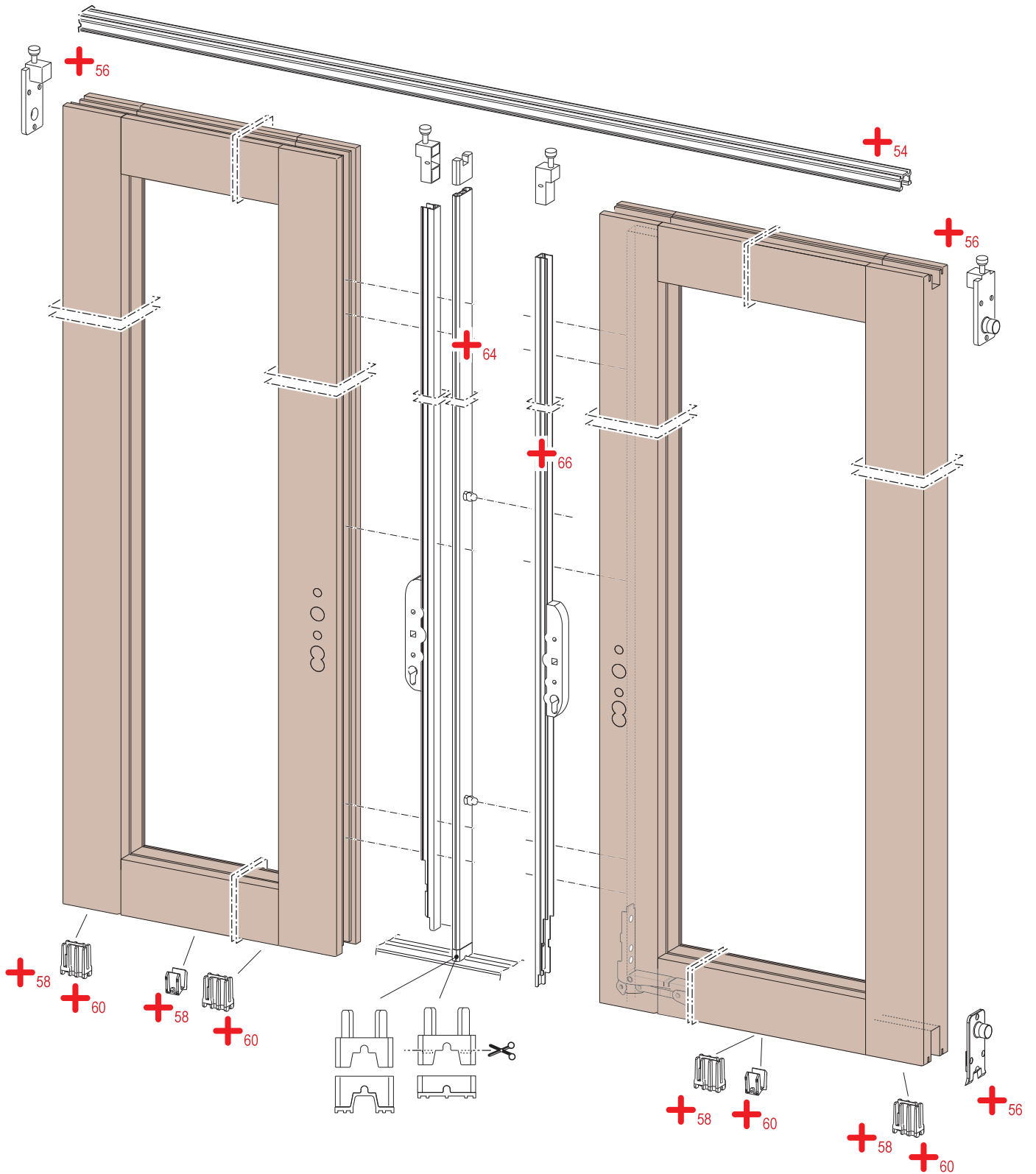

Carriers and locks in this picture are indicative only.

Accessories for coaxial sashes configuration with guide 22x22

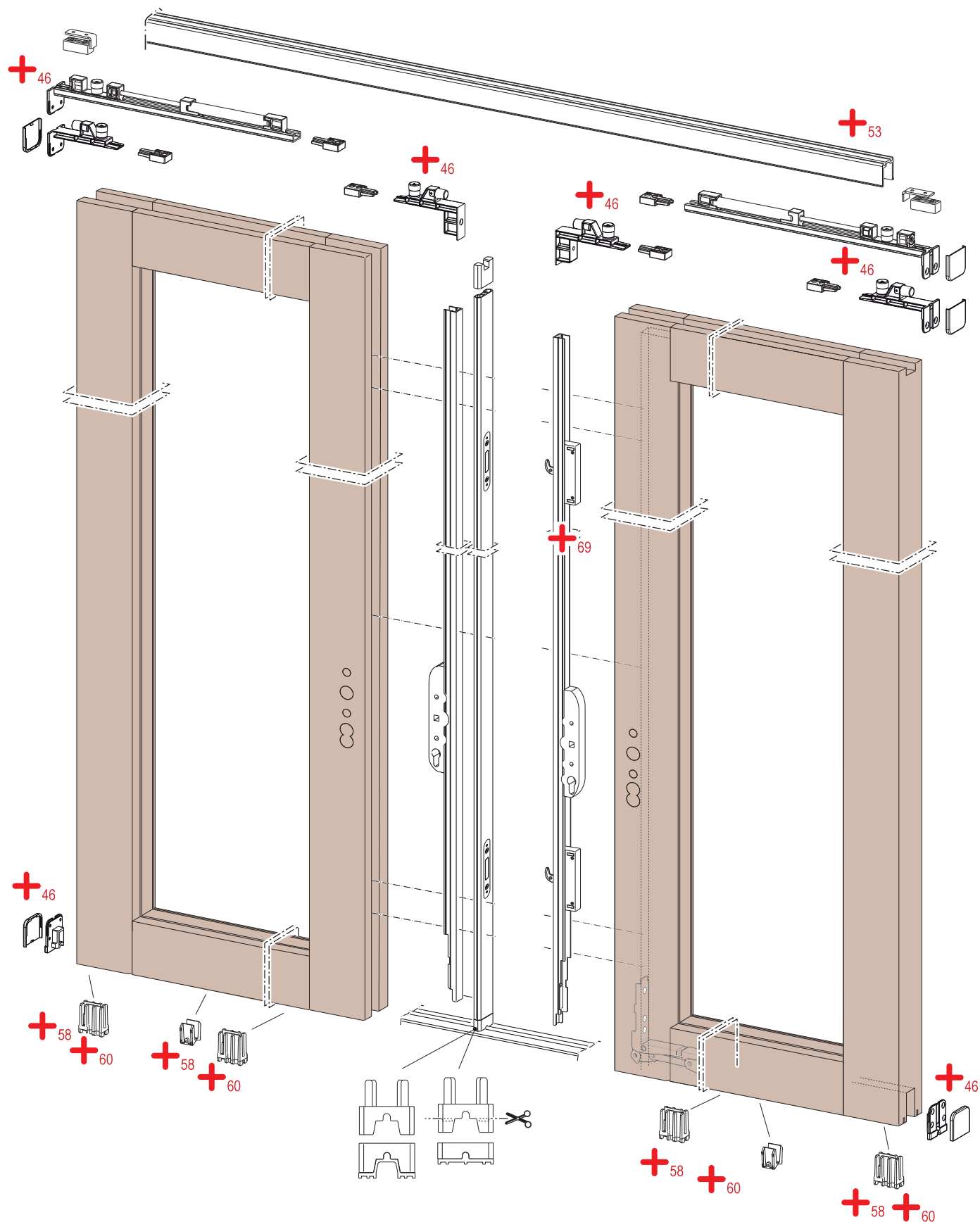

Carriages and locks in this picture are indicative only.

Sash assembly

WITH REDUCED TOP GUIDE AND INSULATING PAD

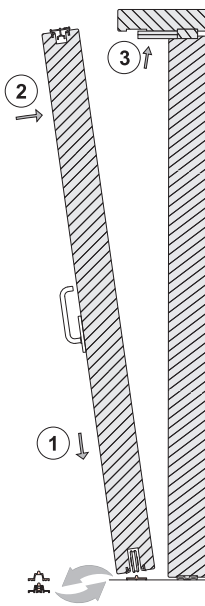

WITH REDUCED TOP GUIDE AND LOCKING PROFILE

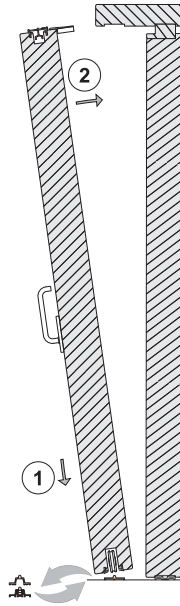

WITH TOP GUIDE AND INSULATING PAD

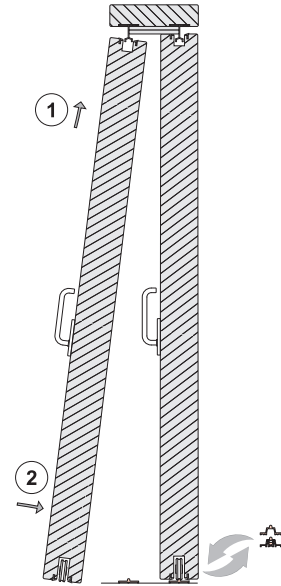

Locking pins assembly

+₆₃

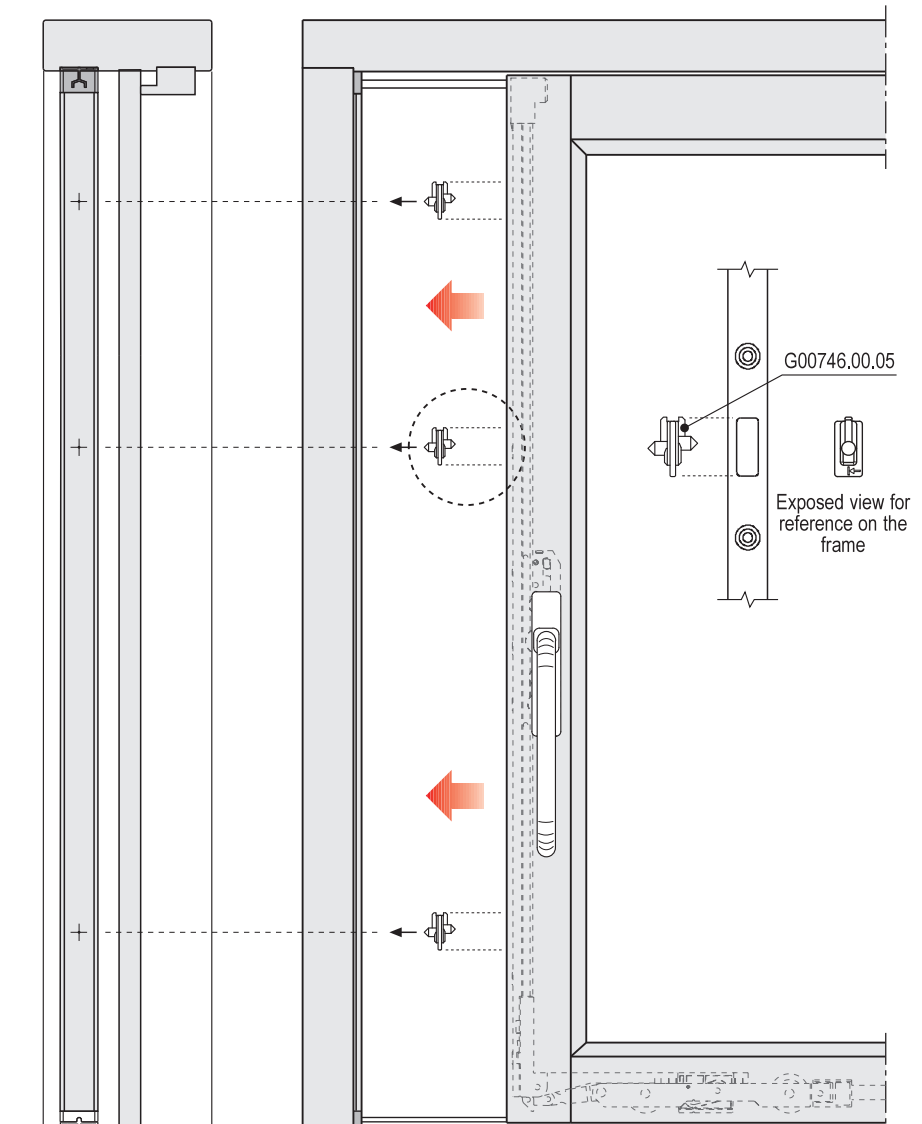
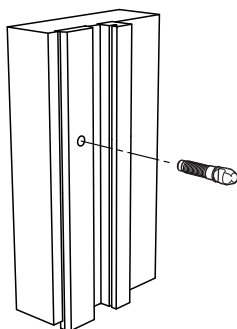
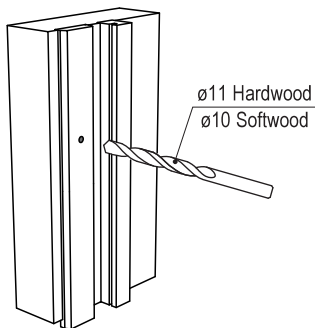

Frame corner joint (alternative solution)



Solution valid only for systems with frame of a thickness of 56 mm; frame jamb-crossbeam assembly using G00728.00.23 kit ensures simple, safe mounting of the entire system, also ensuring optimal mechanical resistance and damp-proofing.

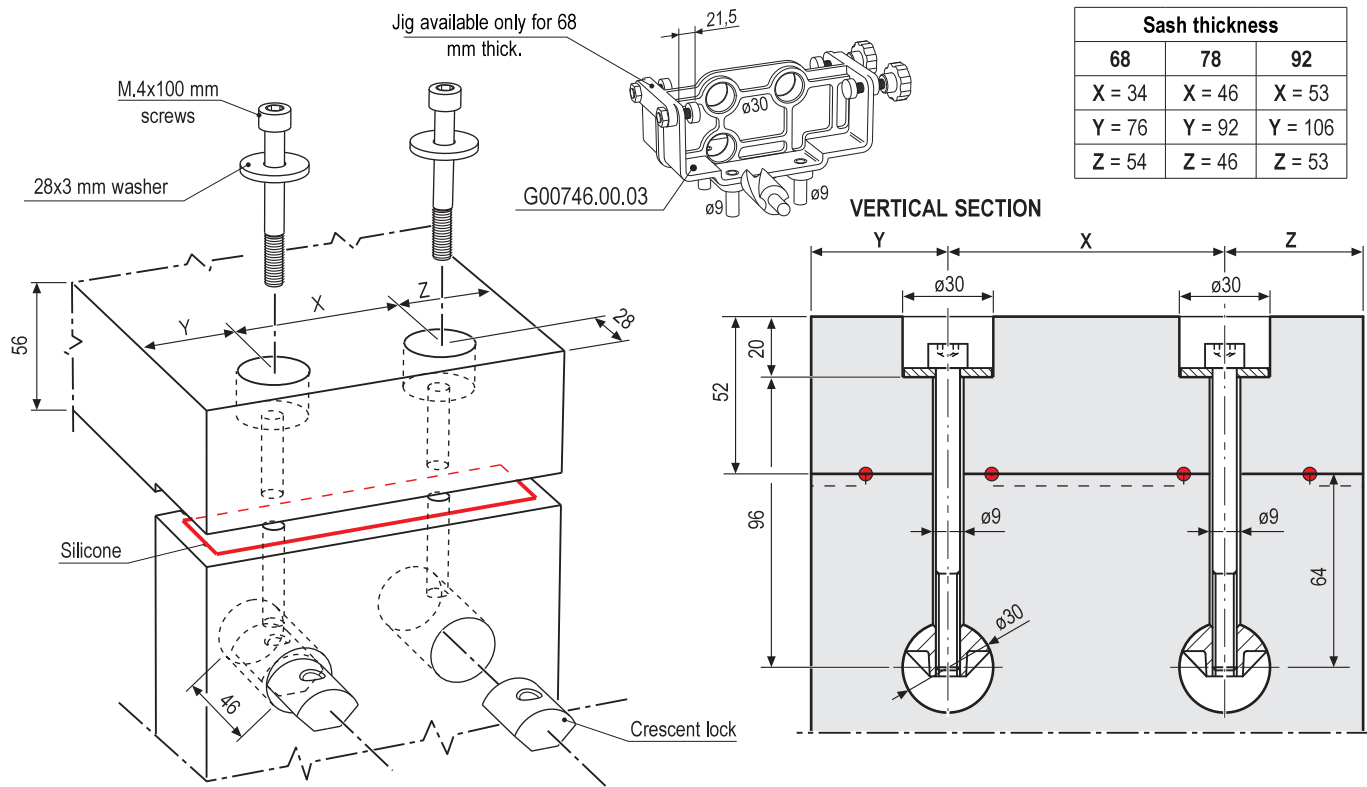

Use of gas spring kit

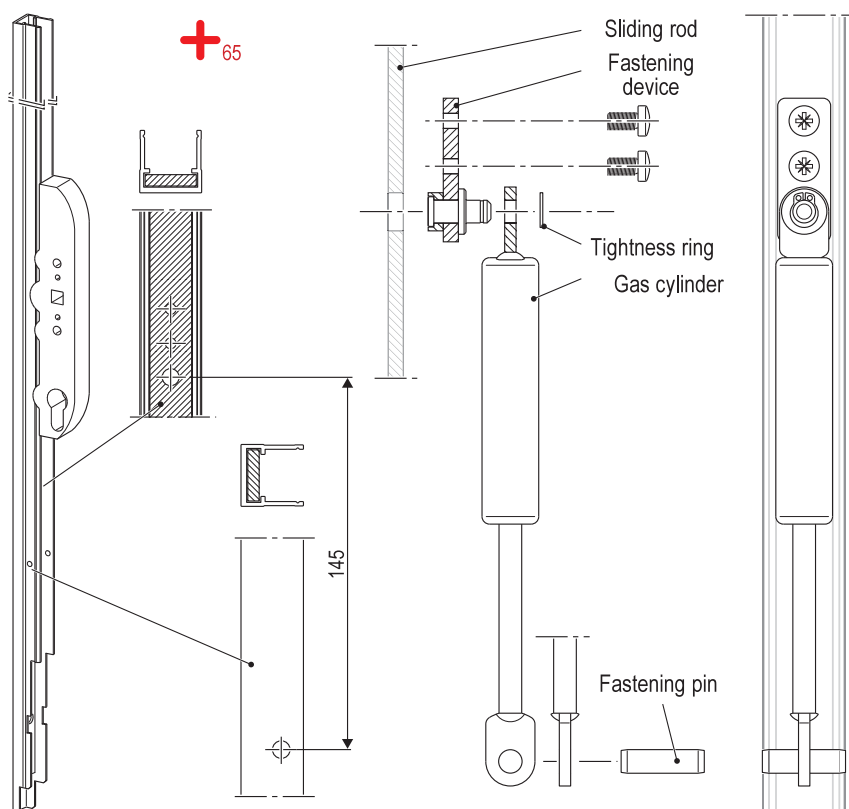

STEPS FOR THE CONTROL OF PRODUCTION PROCESS (FPC)

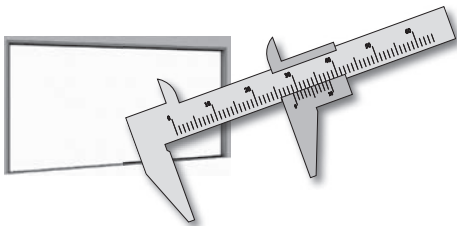

Frame components measurement and solutions for air-water tightness

- 1 - Find the length and width of upper transom and vertical jambs.
- 2 - Check the length and depth of millings to host the aluminium upper guide and wooden listels are compliant to what indicated in this technical manual.
- 3 - Check the width and length of listels.
- 4 - Check that the length of threshold, the sliding profile and the glass holder profile corresponds to the indications of this technical manual.

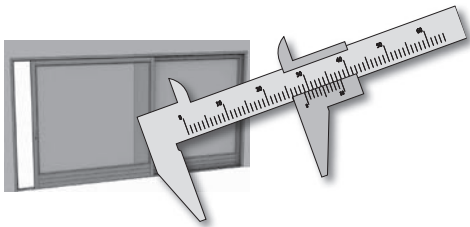

Sashes components measurement and solutions for air-water tightness

- 1 - According to the frame measurements, please calculate the sashes measurements according to the indications reported in the technical manual (LxH) and check that sash dimensions are compliant to the ones calculated before.
- 2 - Check the sashes orthogonality (square) measuring the diagonals, it is very important they are equal for the correct functioning and closing.
- 3 - Check the sash adapter is exactly the one indicated in this manual.
- 4 - Check the millings width for the carriages housing and check that they are in the middle of the sash thickness.
- 5 - Check the depth and width of millings to host the gaskets checking the status, they can't have dirt or glue/paint.
- 6 - Check the depth and position the lock milling.
- 7 - Check the coplanarity of jamb/lower transom joints, eventually level with stucco in order to keep the tightness strong.
- 8 - The double glazing glass has to be siliconed flush to the rebate, perimetrically from outside, on wooden frames and aluminium glass holder profile.
- 9 - Silicone even on internal glass holder or use specific gaskets.
- 10 - Make a silicone bead around perimeter inside the external lower gasket groove before inserting it.

TECHNICAL ATTACHMENTS

Caps kit for embedded upper guide 22x22

Article	Ref.	Description	Material	Use	Fastening
Rear lower cap	❶	It covers the carriage milling of the lower transom.	Plastic material	It covers the sash lower milling.	3,5x20 mm screws.
Cover (2x)	❷	Cover for the lower cap and the rear bumper glider.	Plastic material	It covers the lower cap and the fastening of the upper rear glider.	Snap-in
Shaped cap for upper guide	❸	Cap to be inserted between the locking profile and the guide.	Rubber	To be jointed.	To be inserted with silicone.
Shaped cap for lower rail	❹	To guarantee the system tightness.	Rubber	Apply under the profile with silicone on the back.	
Device for frame guide	❺	Rebate for the glider pad or for the damper.	Zamak	To be placed and fastened into the upper guide.	4x45 mm screws.
Glider fastening hold-device and damper (2x)	❻	Mechanical block of the glider.	Zamak	Fasten using front and rear caps as a jig.	4x30 mm screws.
Front cap with reference glider	❼	Sliding glider and closing brake.	Plastic material / zamak / steel	To fasten the sash in opening.	4x30 mm screws.
Damper kit with closing brake	❽	Sliding glider and opening brake.	Plastic material / zamak / steel	To fasten the sash in opening.	4x30 mm screws.
Fixed sash adapter (x4)	❾	Filling adapter for fixed sash.	Plastic material	Compensator adapter between sash and frame.	To be inserted.

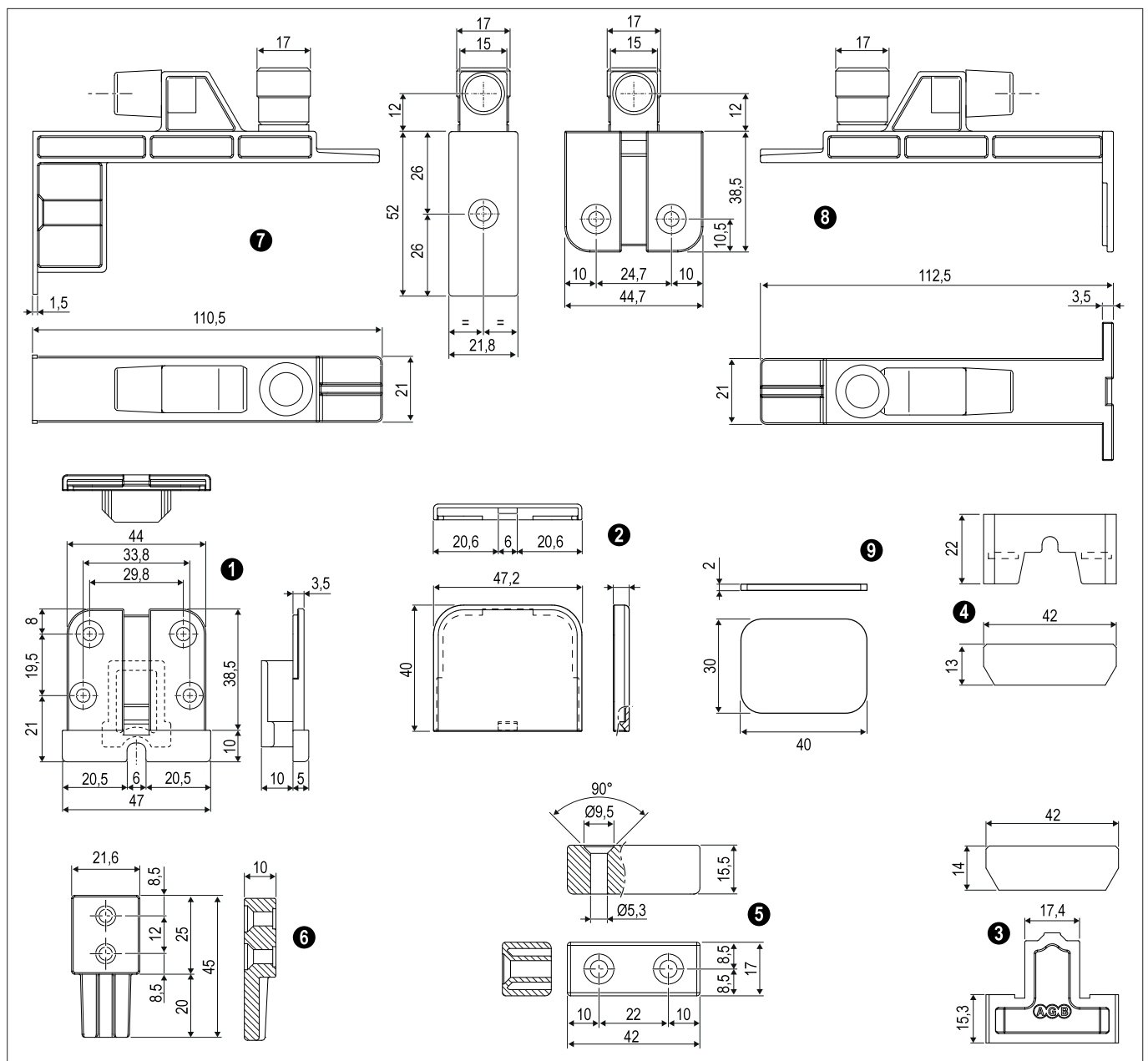

Caps kit for embedded upper guide 22x22

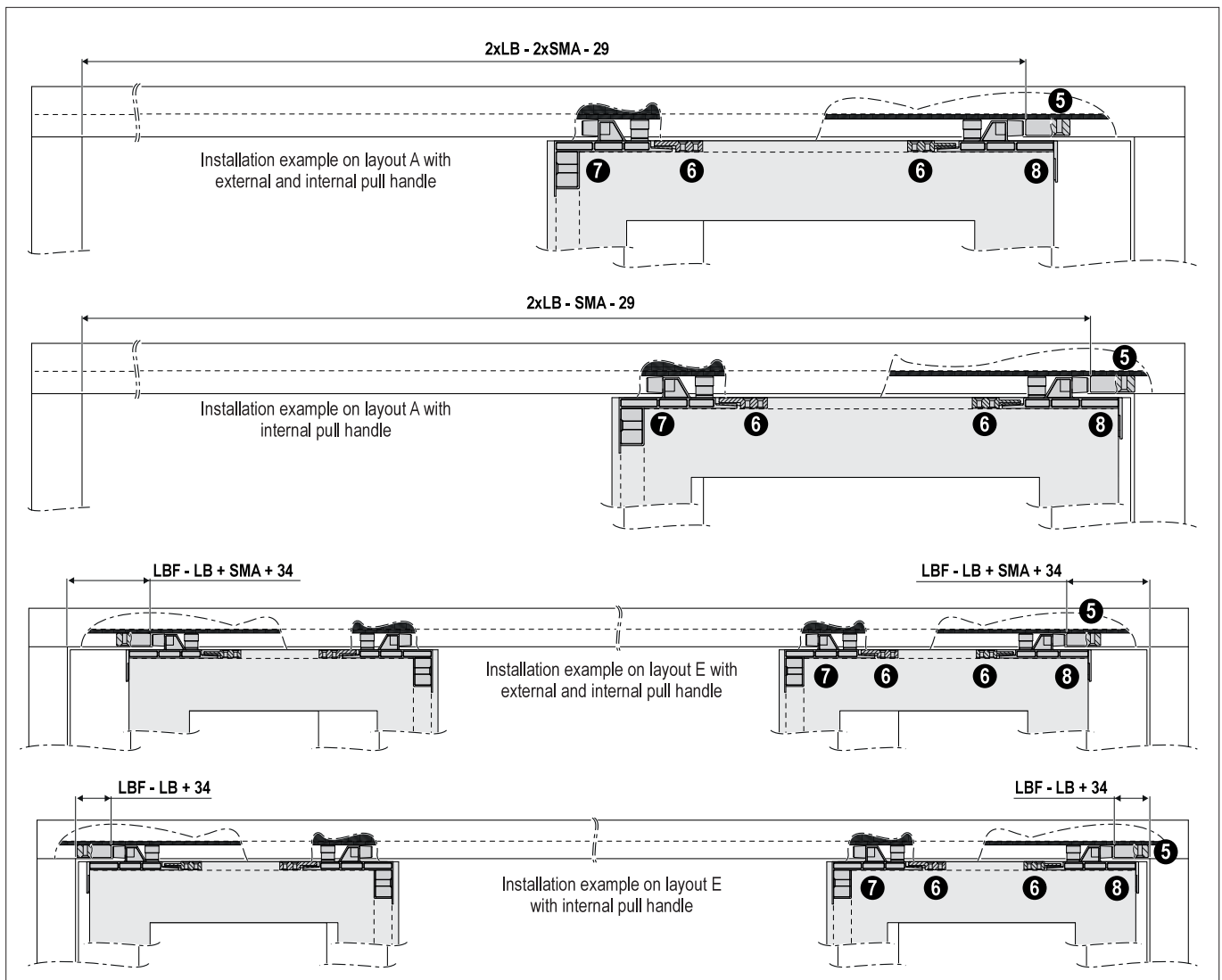
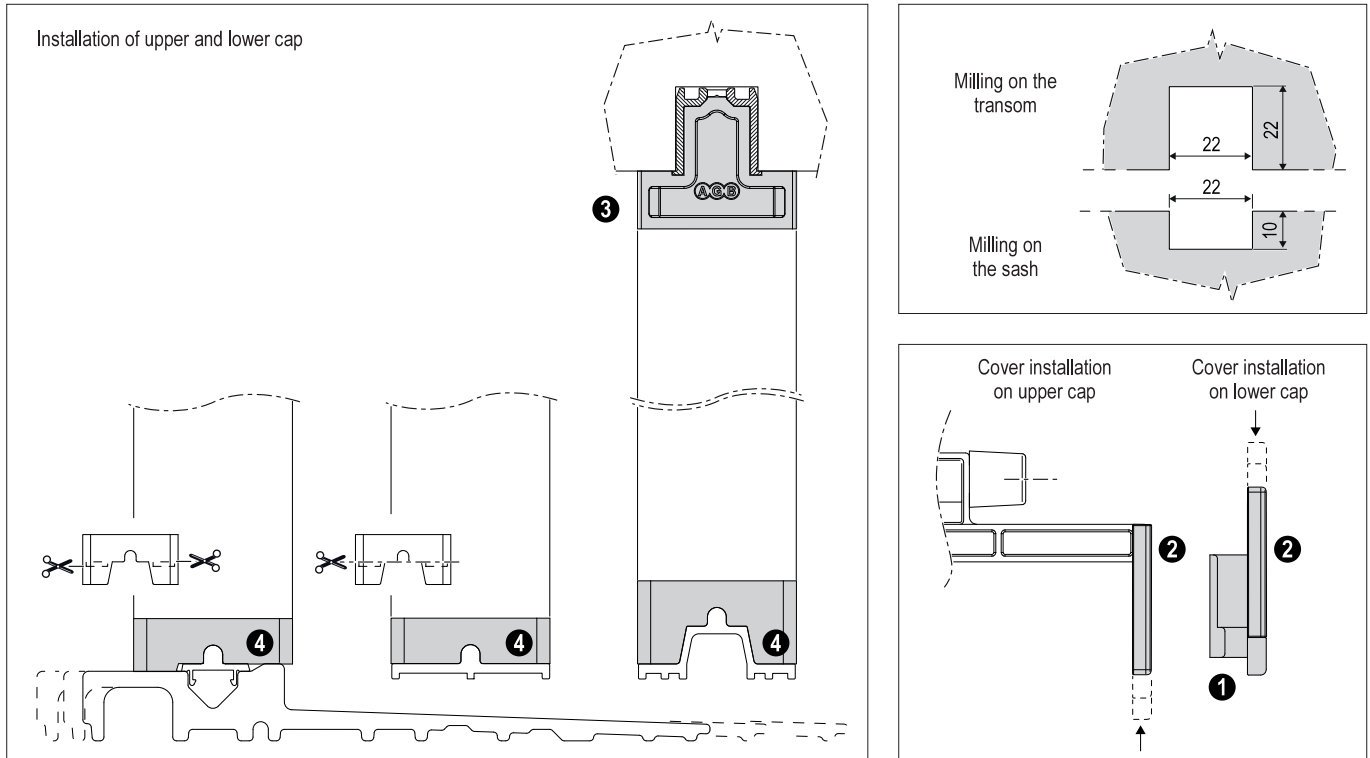

Caps kit for embedded upper guide 22x22

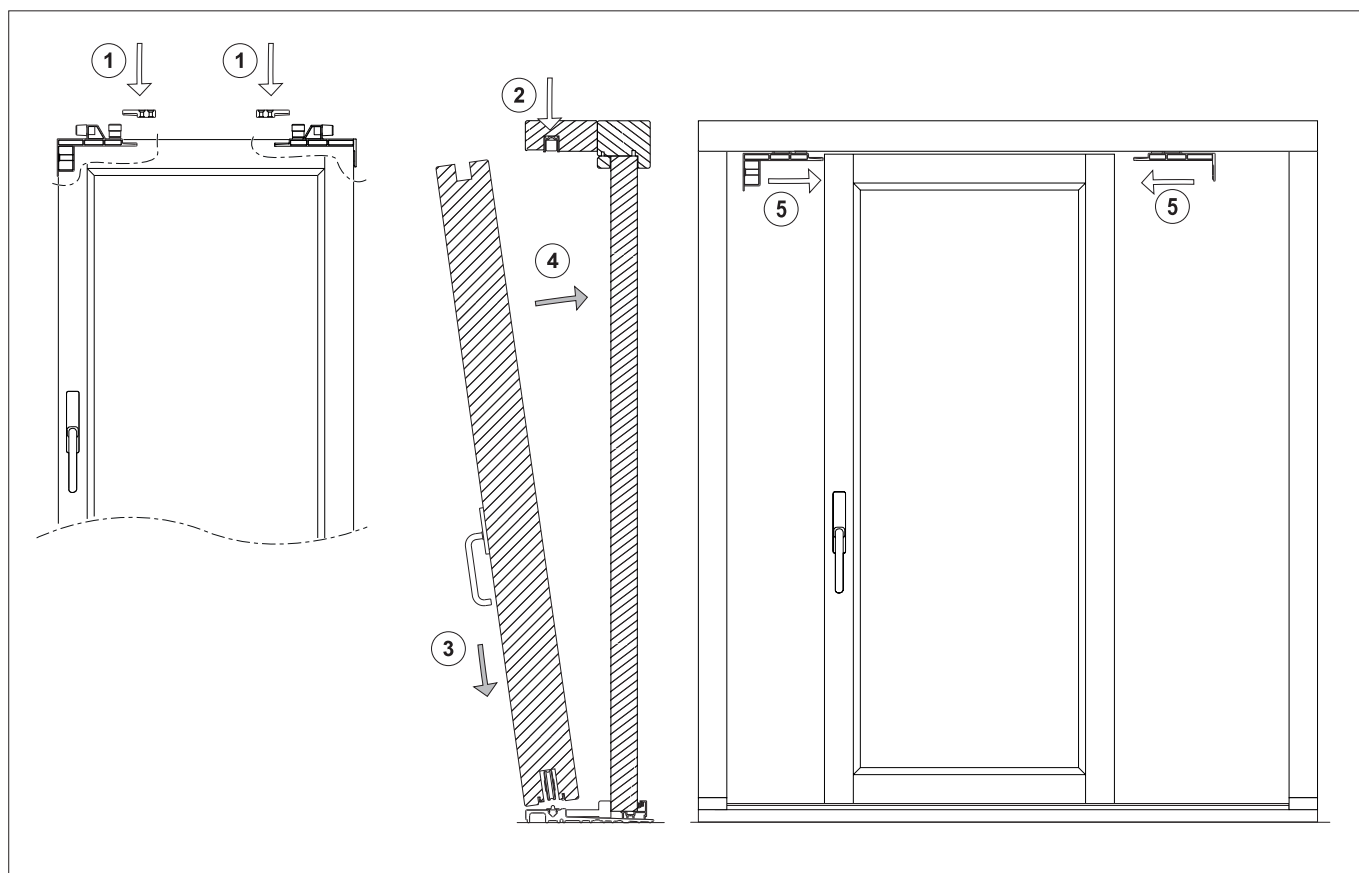

- ① Using the glider/s as a jig, fasten the hold device/s into the sliding sash, not installed yet; then, remove the caps;
- ② Place the device/s in the right position indicated in this technical documentation;
- ③ Place the sash on the rail with the carriages in opening position;
- ④ Place the sash in vertical position;
- ⑤ Fasten the gliders on the sliding sash.

Article	Grey RAL 7035	Black
Caps kit for embedded upper guide 22x22	G00232.00.86	G00232.00.93

Damper kit with opening brake

Article	Ref.	Description	Material	Use	Fastening
Rear cap with glider as a guide	①	Sliding glider and opening brake.	Plastic material / zamak / steel	To fasten the sash in opening.	4x30 mm screws.
Magnetic contrast	②	It allows the damper activation in closing/opening.	Steel	To be applied under the contrast as a guide if you use the brake.	4x30 mm screws.

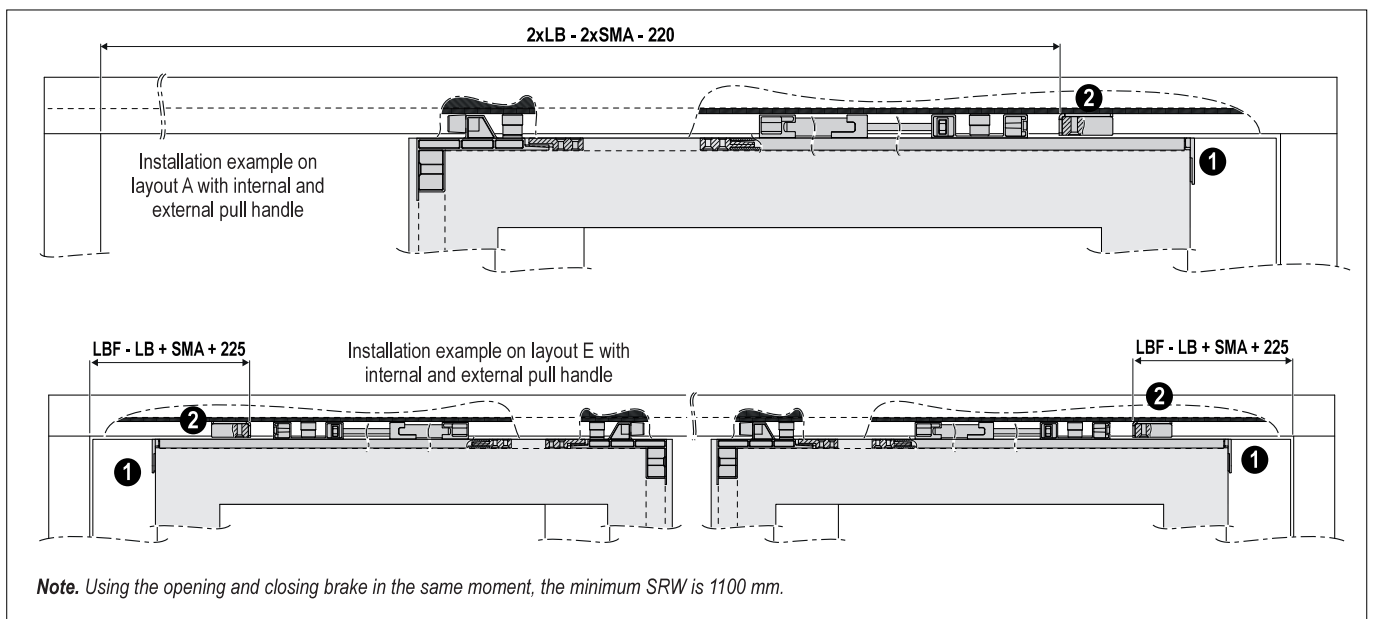
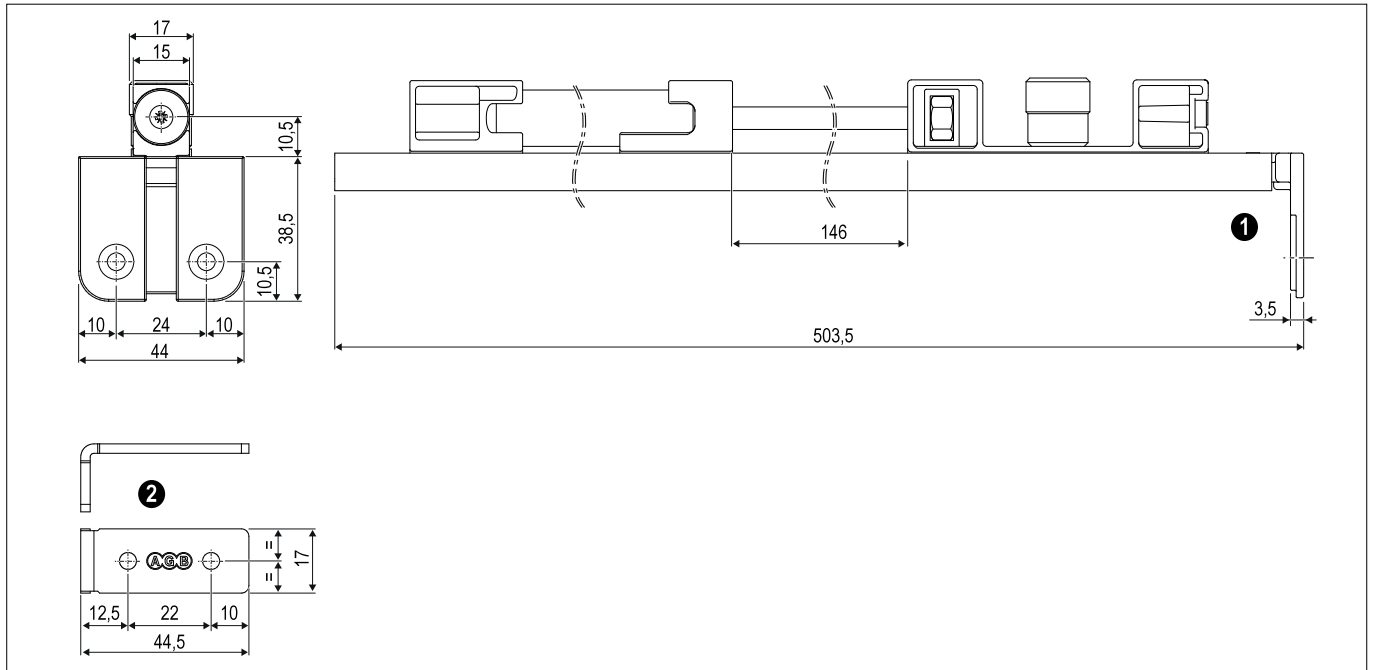

Damper kit with opening brake

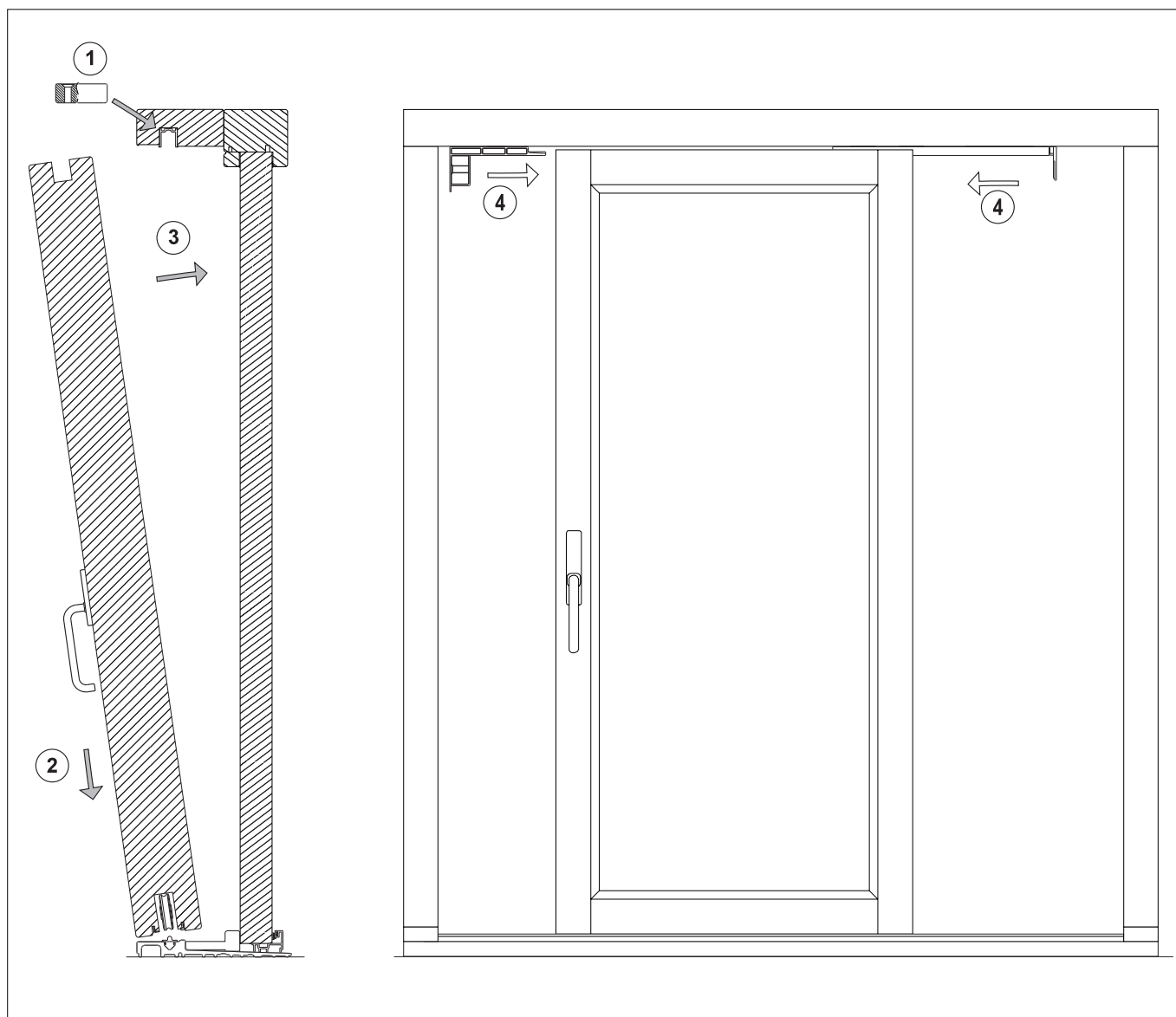

- ① Place the device/s in the right position indicated in this technical documentation;
- ② Place the sash on the rail with the carriages in opening position;
- ③ Place the sash in vertical position;
- ④ Fasten the gliders on the sliding sash.

Article	Grey RAL 7035	Black
Loading capacity 80-200 kg	G00232.13.86	G00232.13.93
Loading capacity 200-440 kg	G00232.14.86	G00232.14.93

Damper kit with closing brake

Article	Ref.	Description	Material	Use	Fastening
Front cap with damper	❶	Sliding glider and closing brake.	Plastic material / zamak / steel	To stop the sash in opening.	4x30 mm screws.
Magnetic contrast	❷	It allows the damper activation in opening.	Steel	To be applied under the contrast as a guide if you use the brake.	4x45 mm screws.
Device for frame guide	❸	Rebate for the glider pad or for the damper.	Zamak	-	4x45 mm screws.

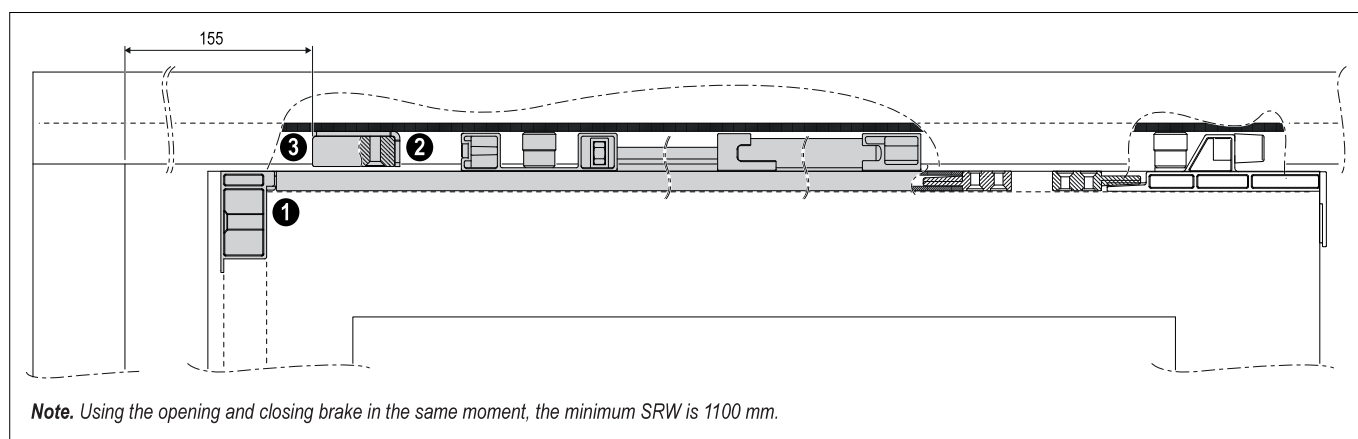
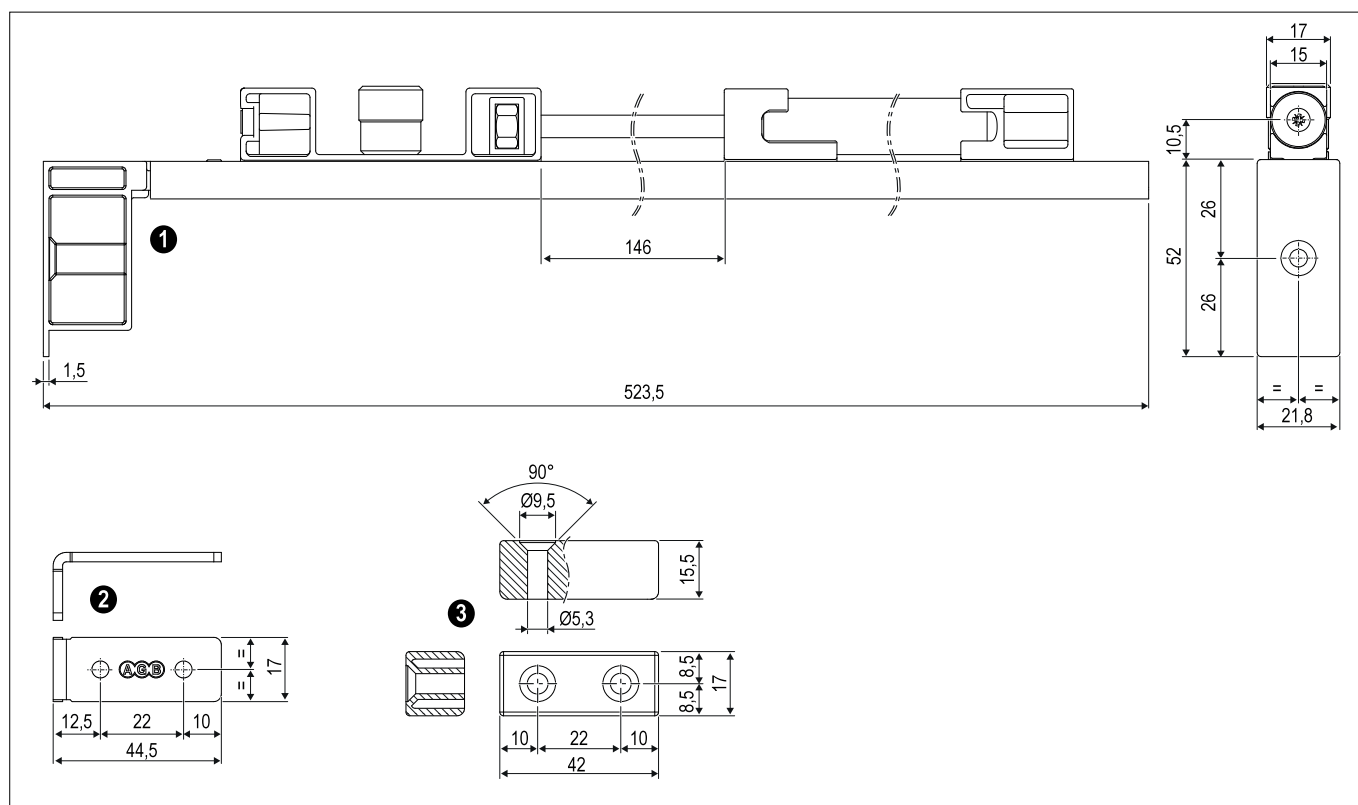

Damper kit with closing brake

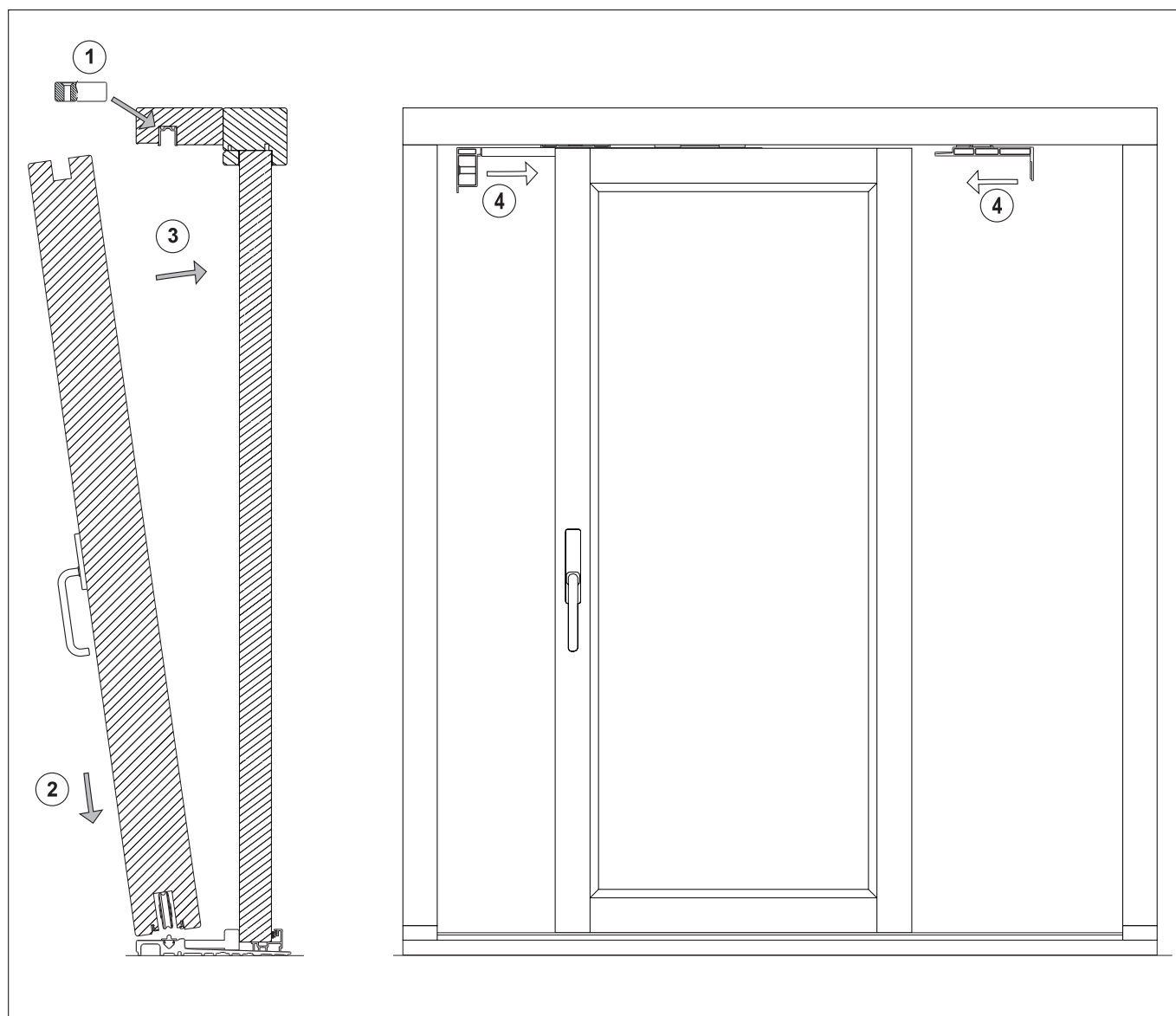

- ① Place the device/s in the right position indicated in this technical documentation;
- ② Place the sash on the rail with the carriages in opening position;
- ③ Place the sash in vertical position;
- ④ Fasten the gliders on the sliding sash.

Article	Grey RAL 7035	Black
Loading capacity 80-200 kg	G00232.11.86	G00232.11.93
Loading capacity 200-440 kg	G00232.12.86	G00232.12.93

Embedded upper guide 22x22

Article	Ref.	Description	Material	Use	Fastening
Embedded upper guide	❶	Guide for sliding gliders of the sliding sash, compatible with AGB systems of closing/opening brake.	Aluminium	Insert in the dedicated milling of the frame upper transom.	4x25 mm screws.

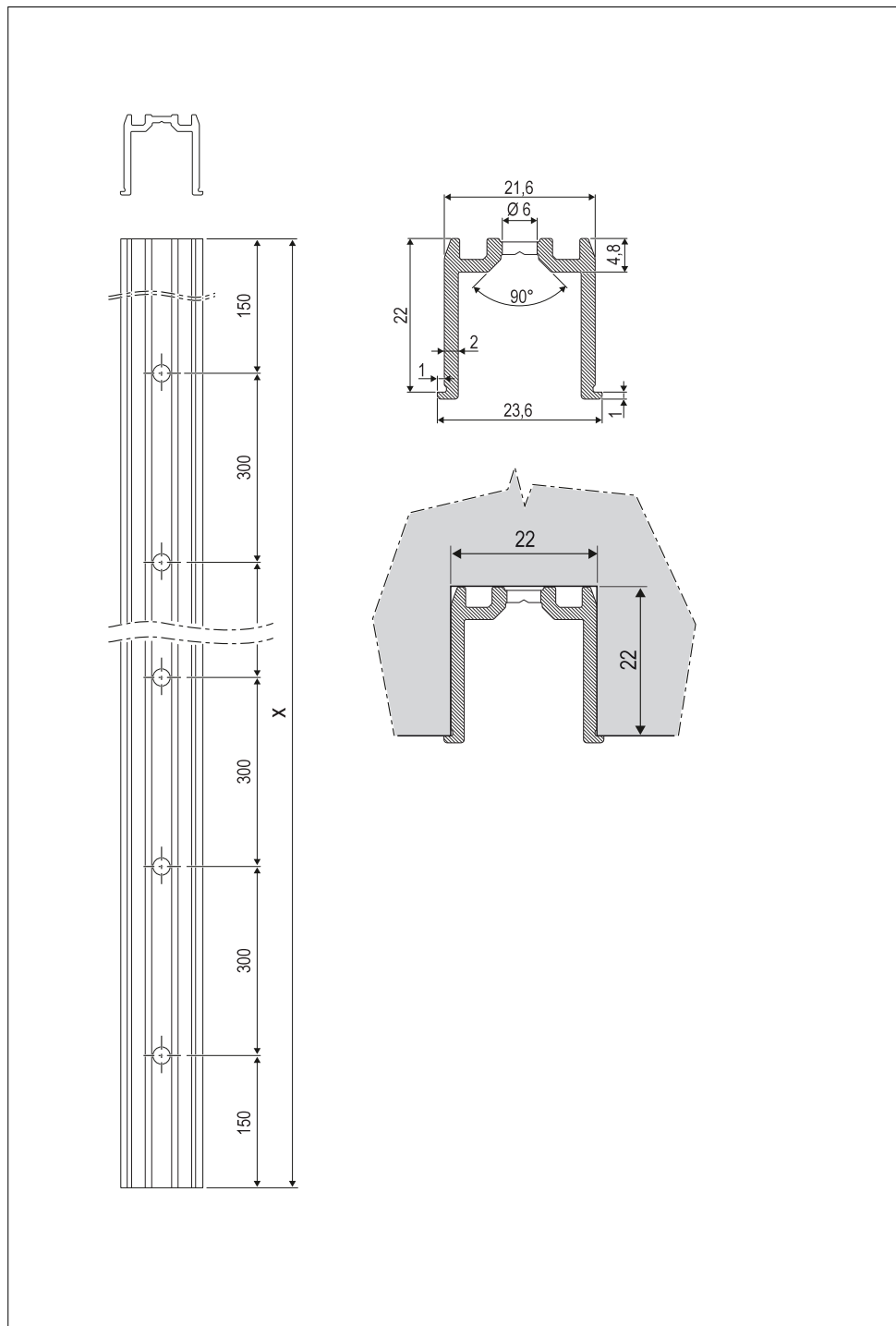

Ref.	Article	Article code, in Silver	Article code, in Electrocoulour	X
❶	Embedded upper guide	G01002.01.01	G01002.01.02	3000
		G01002.02.01	G01002.02.02	4000
		G01002.03.01	G01002.03.02	5000
		G01002.04.01	G01002.04.02	6000
		G01002.05.01	G01002.05.02	7000

Embedded upper guide 22x13

Article	Ref.	Description	Material	Use	Fastening
Embedded upper guide 22x13	❶	Guide for sliding gliders of the movable rod.	Aluminium	Insert in the dedicated milling of the frame upper transom.	4x25 mm screws.

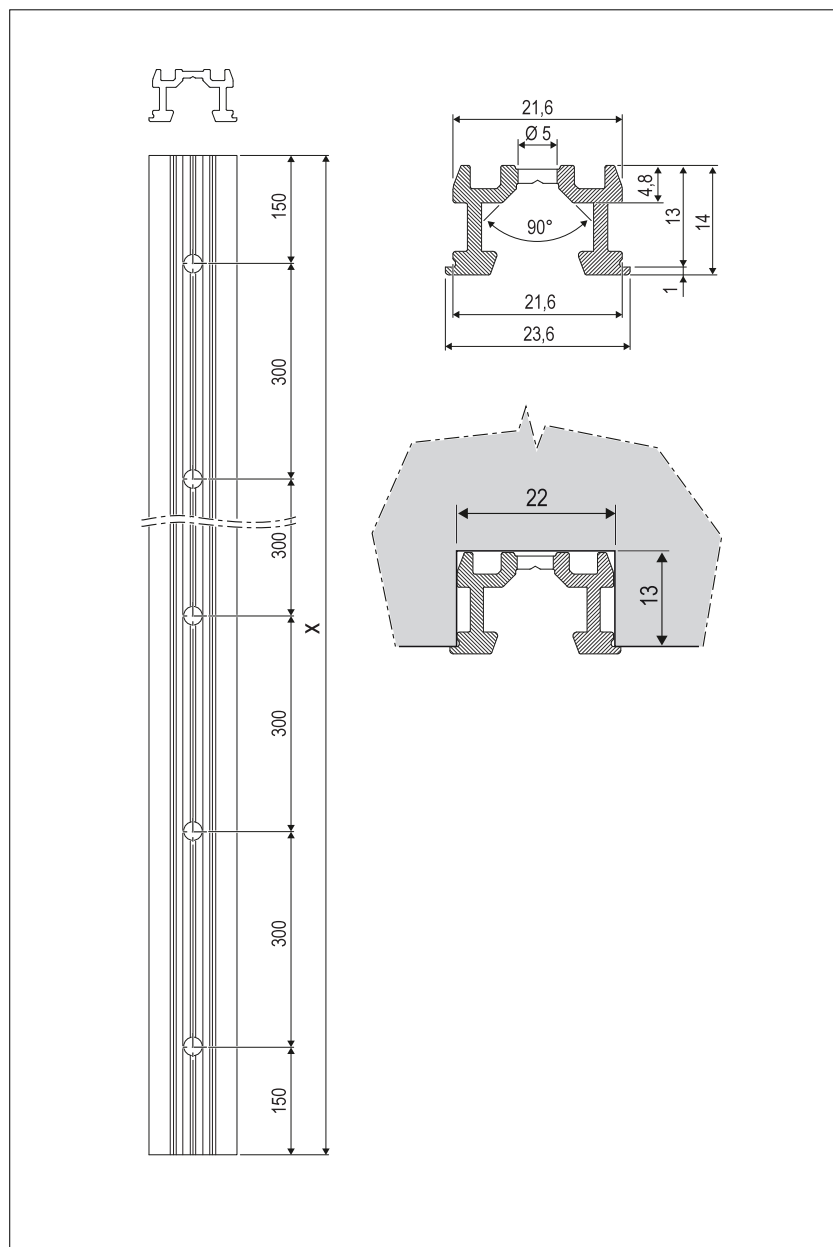

Ref.	Article	Article code, in Silver	Article code, in Electrocoulour	X
❶	Embedded upper guide 22x13	G01000.01.01	G01000.01.02	3000
		G01000.02.01	G01000.02.02	4000
		G01000.03.01	G01000.03.02	5000
		G01000.04.01	G01000.04.02	6000
		G01000.14.01	G01000.14.02	7000

Reduced top guide

Article	Description	Material	Fastening
Reduced top guide	Guide profile in anodized aluminium, with screw holes every 30 cm.	Aluminium	3,5X30 screws

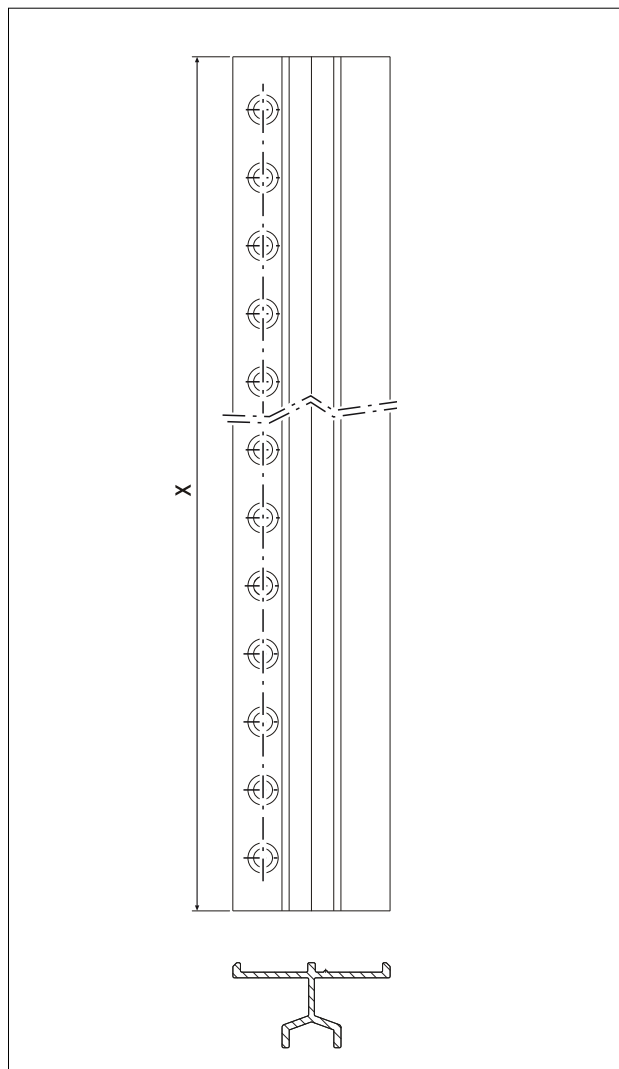

Ref.	Description	Silver	Aluminium Black	X
❶	Reduced top guide	G01734.01.01	G01734.01.02	3000
		G01734.02.01	G01734.02.02	4000
		G01734.03.01	G01734.03.02	5000
		G01734.04.01	G01734.04.02	6000
		G01734.05.01	G01734.05.02	7000

Caps kit for embedded upper guide 22x13 - low rail

Article	Ref.	Description	Material	Use	Fastening
Shaped cap for C track 22x13	1	Cap to be inserted between the locking profile and the guide.	Rubber	To be jointed.	To be inserted with silicone.
Shaped cap for lower rail	2	To guarantee the system tightness.	Rubber	Apply under the profile with silicone on the back.	
Rear lower covering cap	3	Cap to close the hardware groove on the lower transom, in the sash extremity.	Plastic material	-	4x30 mm screws.
Cap and glider for front upper guide	4	Glider for the sash sliding on the concealed guide; the plastic glider is used as covering cap of the upper milling.	Plastic material	Place in the slot between sash and frame.	4x30 mm screws.
Cap and glider for rear upper guide	5				
2 mm adapter for fixed sash	6	Adapter for the fixed sash fastening.	Plastic material	-	To be inserted.

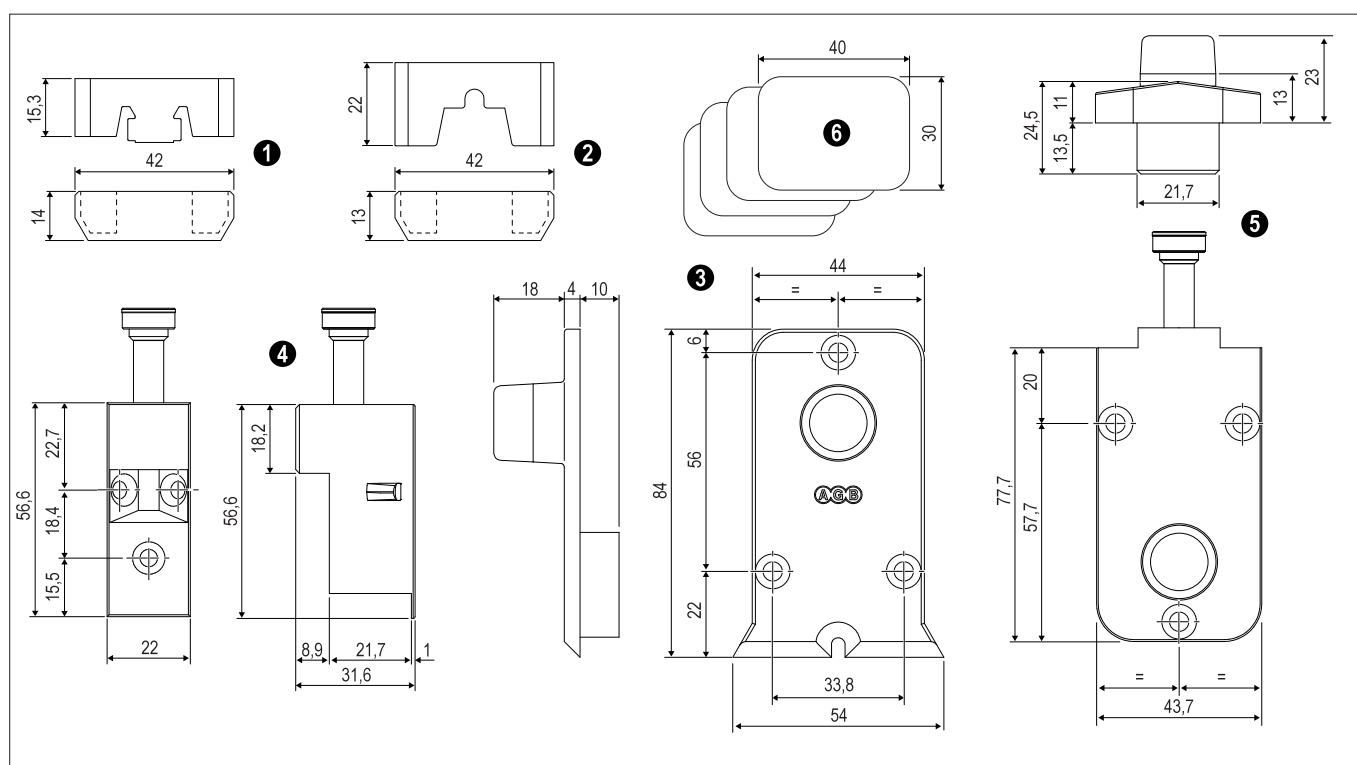

Caps kit for embedded upper guide 22x13 - low rail

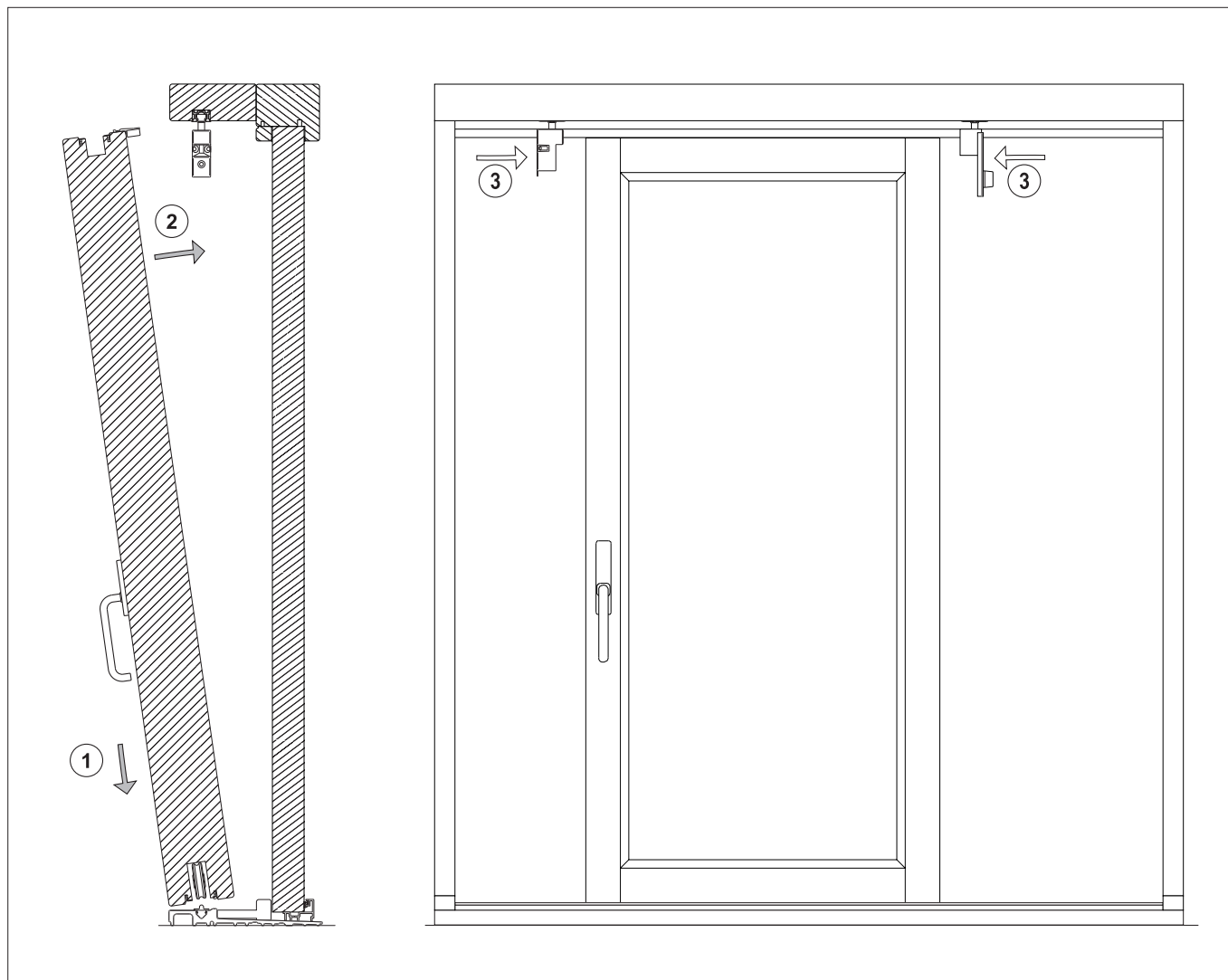

- ① Place the sash on the rail with the carriages in opening position;
- ② Place the sash in vertical position;
- ③ Fasten the gliders on the sliding sash.

Article	Grey RAL 7038	Black
Caps kit for embedded upper guide 22x13 (Imago) - Low rail	G00223.01.86	G00223.01.93

330 kg carriages kit, 440 kg supplementary carriages kit, carriages connecting rod

Article	Ref.	Description	Material	Use	Fastening
Carriages kit, 300 kg	1	Two carriages (front and rear, non-handed) with lift device and lever and rings. The connection between the two carriages is provided by the through cuttable rod. The hooking of the connecting rod is guaranteed by locking grubs with milled base to avoid possible loosening.	Steel	Sliding sashes of weight ≤ 330 Kg	Screws 4,5x35 mm
Carriages kit, 300 kg with adjustable rear carriage	2	Standard front carriage; rear carriage with +3,5 mm in height.			
Supplementary carriages kit	3	Two carriages with lift device. Each carriage has to be coupled to a carriage of the 330 kg kit (front and rear) through connecting rod and locking grubs.	Steel	Sliding sashes of weight ≥ 330 Kg and ≤ 440 kg	Screws 4,5x35 mm
Carriages connecting rod	4	It ensures the connection between a carriage and the other and transfers the movement of opening/closing.	Steel	Cuttable 1 piece	Grubs provided
Bumper / support	5	It allows to download the carriage weight from the sash to the snap-in rail; suitable for aluminium systems where the sash weight in closing position can't be downloaded to the gaskets.	Plastic material	1 for each carriage	Snap-in rail
Rod guide	6	Inserted into the carriage milling, it ensures the correct operation of connecting rod.	Plastic material	1 for each sliding sash	Screws 4x30 mm
Anti-derailed adapter	7	Dedicated zamak adapter that prevents the derailing movement of sliding sash carriages after forces which are orthogonal to the sliding axis (e.g. weather conditions).	Zamak	Install 2 devices on each central sash; install 1 block on each sidesash	Screws 4x30 mm

Note. Level the glass in order to download the weight evenly in correspondance to the carriages.

Note. Please don't distribute the supplementary carriages along the sash but install them coupling the main carriages.

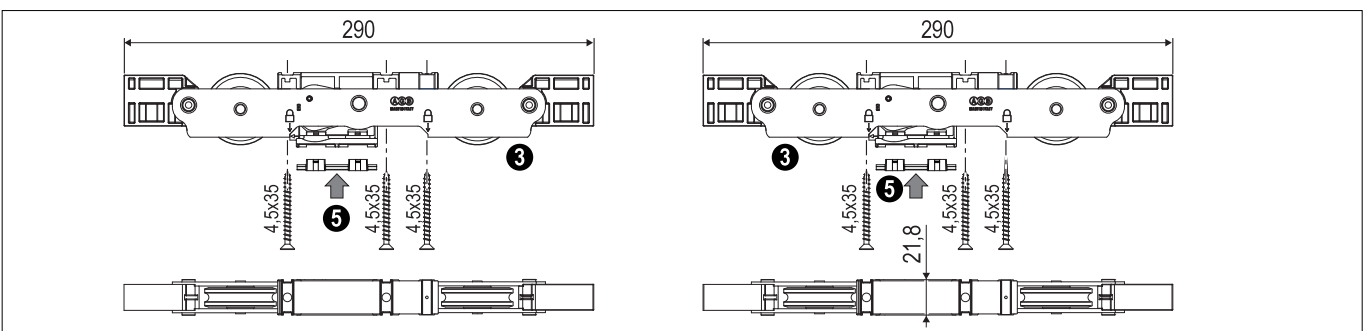
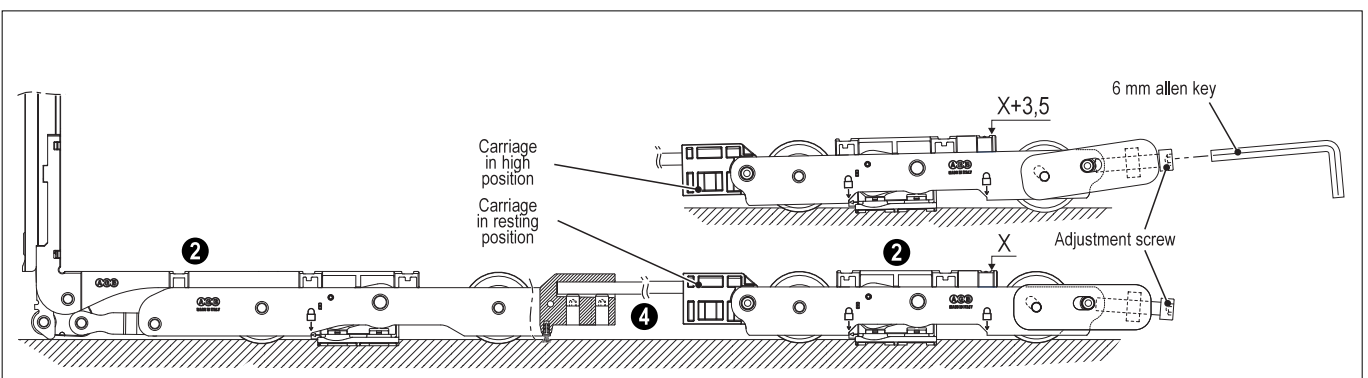
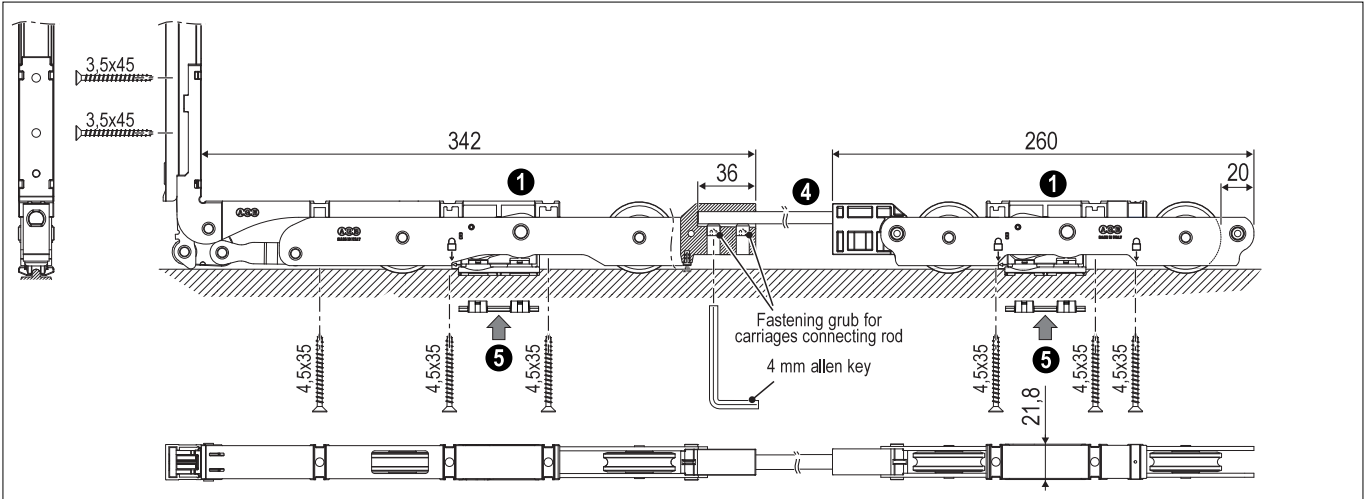

330 kg carriages kit, 440 kg supplementary carriages kit, carriages connecting rod

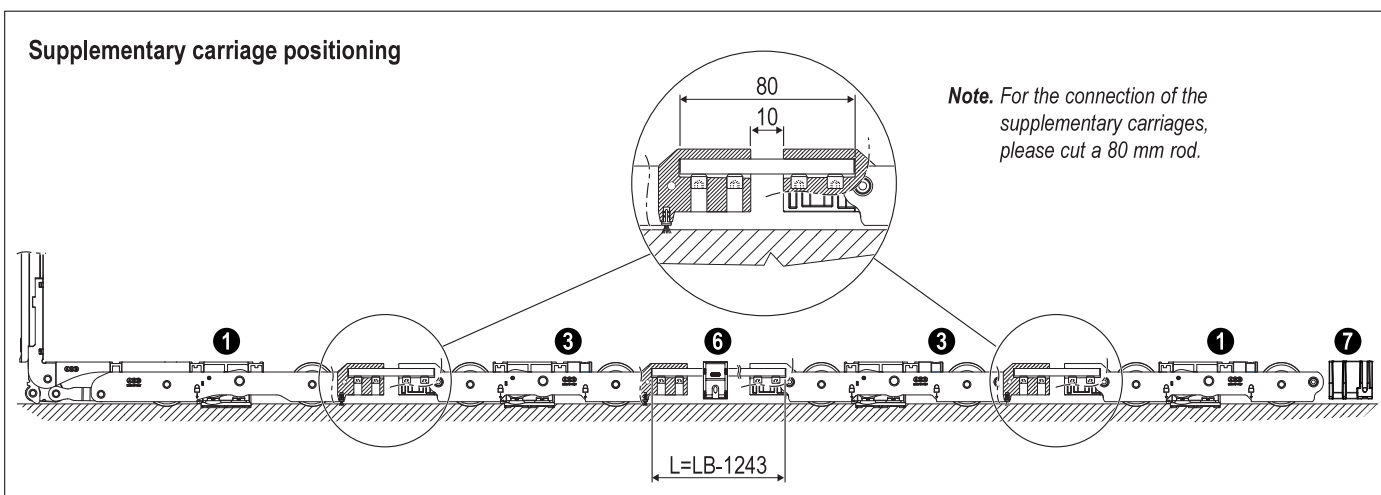
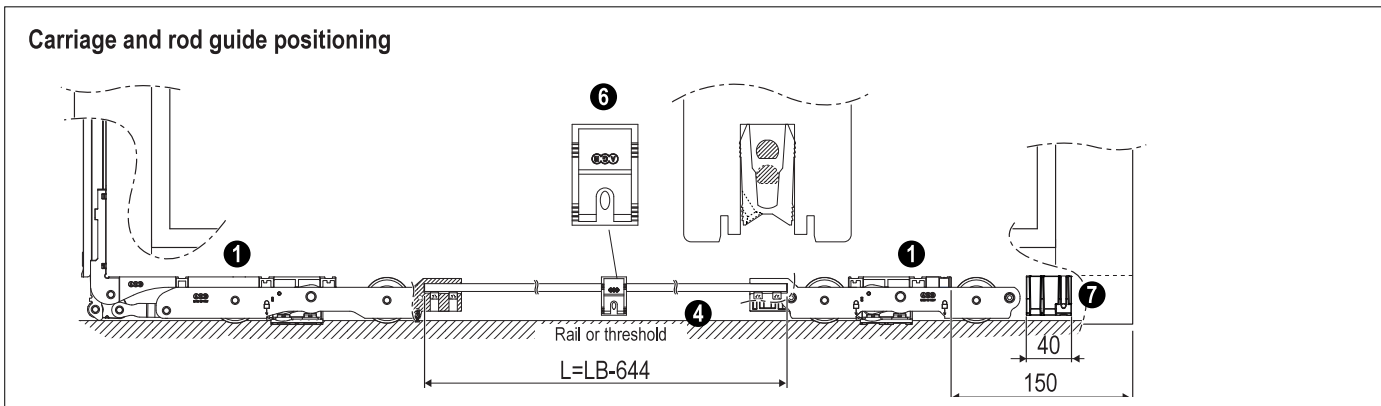
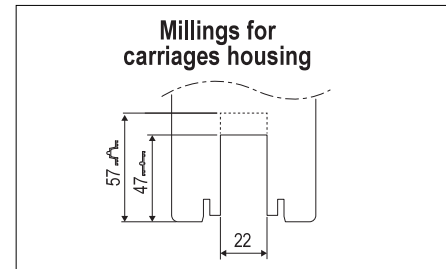
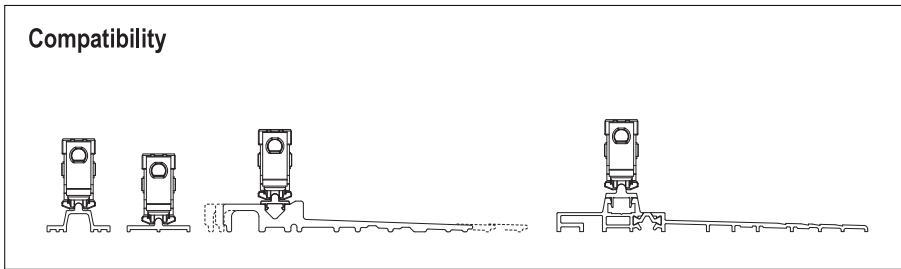

Application fields				
Carriages connecting rod	330 Kg		440 Kg (with supplementary carriages)	
	Min. SW	Max. SW	Min. SW	Max. SW
1000	645	1644	1245	2083
1400		2044		2483
1800		2444		2883
2700		3344		3783

Ref.	Description	Code	Length
1	Carriages kit, 330 kg	G04104.00.00	-
2	Carriages kit, 330 kg, with adjustable rear carriage	G04114.00.00	-
3	Supplementary carriages kit (440 kg)	G04108.00.00	-
4	Carriage connecting rod	G04601.00.01	1000
		G04601.00.02	1400
		G04601.00.03	1800
		G04601.00.04	2700

Ref.	Description	Code
5	Bumper - support	G01437.00.86
6	Rod guide	G05102.00.00
7	Anti-derailed device	G01611.02.00

250 kg XC S-Line carriages kit, 400 kg XC S-Line supplementary carriages kit, XC carriages connecting rod

Article	Ref.	Description	Material	Use	Fastening
Carriages kit, XC S-Line 250 Kg	①	Two carriages (front and rear, non-handed) with lift device and lever and rings. The connection between the two carriages is provided by the through cuttable rod. The hooking of the connecting rod is guaranteed by locking grubbs with milled base to avoid possible loosening.	Steel	Sash weight ≤ 250 Kg	Screws 4,5x35 mm
	②	The adapters allow the carriages assembly on 18 and 22 mm millings.	Plastic material	Use to install the carriages on 18 and 22 mm millings	Clip
Supplementary carriages kit XC S-Line 400 kg	③	Two carriages with lever lifting device and guides. Each carriage has to be coupled with one of the XC S-Line carriages kit (front and rear) by connecting rod and fastening grubbs.	Steel	Sash weight > 250 Kg and ≤ 400 kg	Screws 4,5x35 mm
Connecting rod	④	It ensures the connection between a carriage and the other and transfers the movement of opening/closing.	Steel	Cut 1 piece	Grubs provided
Stop / support	⑤	It allows to download the carriage weight from the sash to the snap-in rail; suitable for aluminium systems where the sash weight in closing position can't be downloaded to the gaskets.	Plastic material	1 for each carriage	Snap-in rail
Rod guide	⑥	Inserted into the carriage milling, it ensures the correct operation of connecting rod.	Plastic material	1 for each sliding sash. Do not use on 16 mm width milling.	Screws 4x30 mm
Anti-derailed adapter	⑦	Dedicated zamak device that prevents the carriages derailment of the sliding sash after orthogonal pushes on the sliding axis (for example weather agents).	Zamak	Install 2 blocks on each central sash; install 1 block on each side sash. Do not use on 16 mm width milling.	Screws 4x30 mm

Note. Level the glass in order to download the weight evenly in correspondence to the carriages.

Note. Please don't distribute the supplementary carriages along the sash but install them coupling the main carriages.

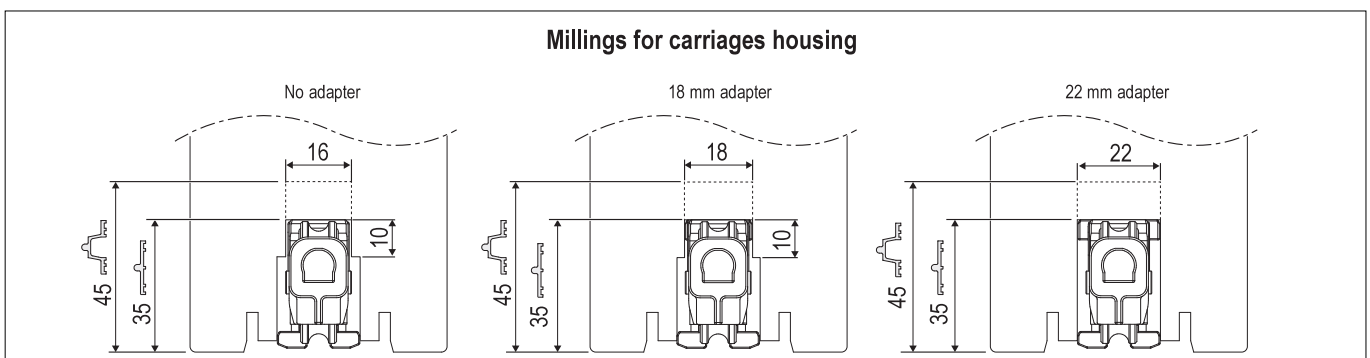
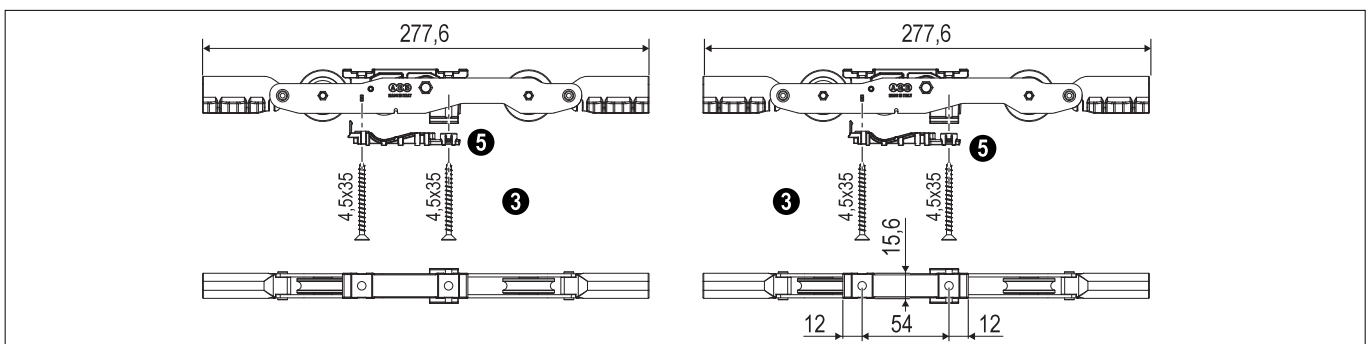
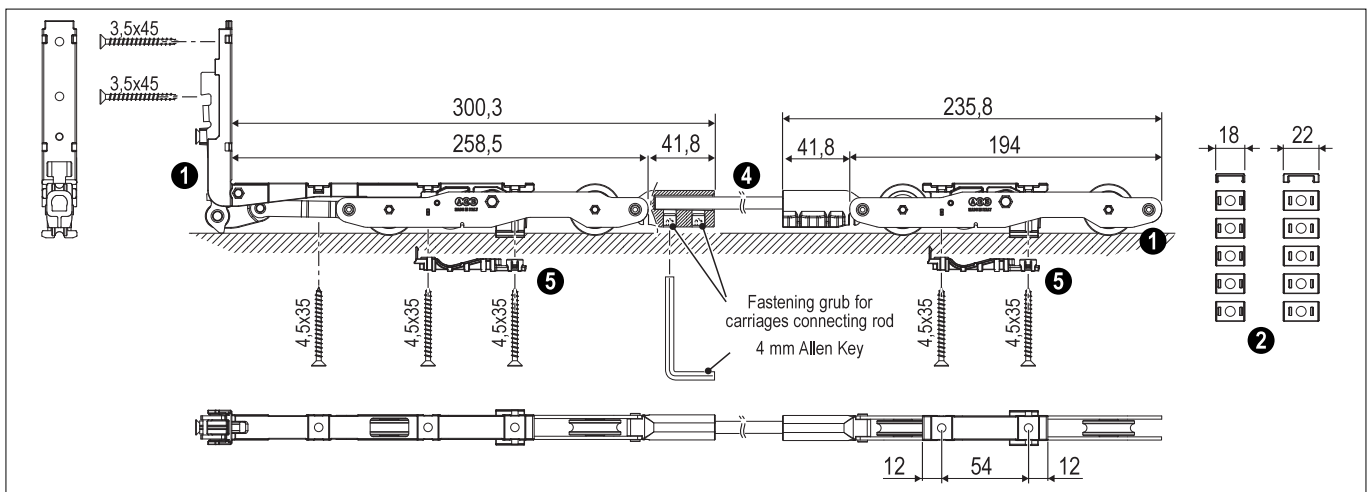

250 kg XC S-Line carriages kit, 400 kg XC S-Line supplementary carriages kit, XC carriages connecting rod

Compatibility

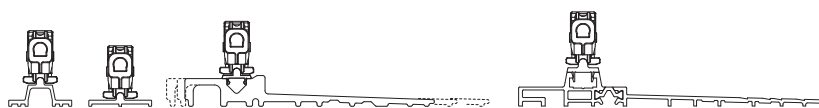

Carriage and rod guide positioning

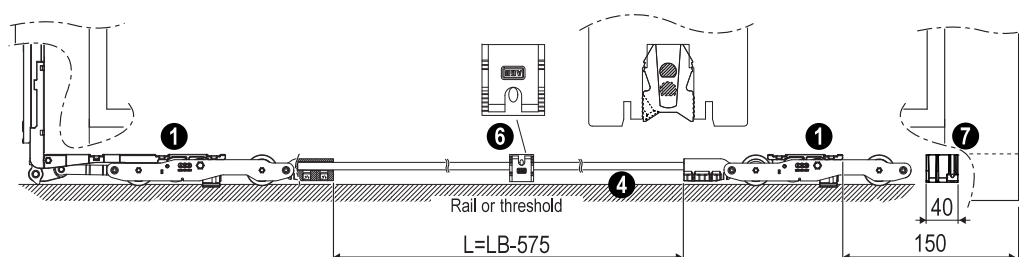

Supplementary carriage positioning

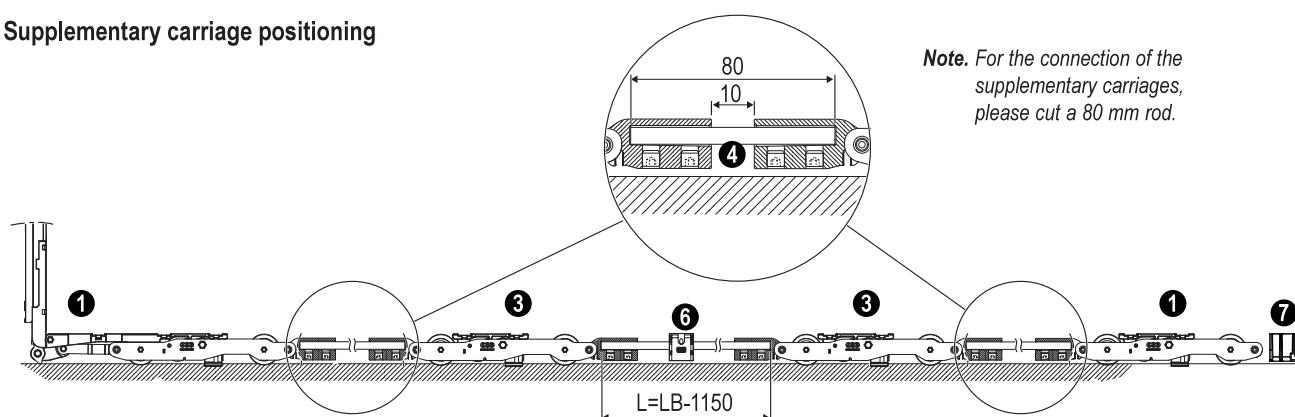

Application fields

Length of connecting rod	250 Kg		400 Kg (with supplementary carriages)	
	Min. SW	Max. SW	Min. SW	Max. SW
1000	580	1575	1160	1990
1400		1975		2390
1800		2375		2790
2700		3275		3690

Ref.	Description	Code	Length
1	250 kg carriages kit	G04109.00.00	-
3	400 kg supplementary carriages kit	G04110.00.00	-
4	Carriage connecting rod	G04601.00.01	1000
		G04601.00.02	1400
		G04601.00.03	1800
		G04601.00.04	2700

Ref.	Description	Code	Length
5	Bumper - support	G02142.00.XX	-
6	Rod guide	G05104.00.00	-
7	Anti-derailed device	G01611.01.00	-

Locking profiles for lateral point and extension

Article	Description	Material	Use	Fastening
1	Pre-drilled locking profile (2 suitable seats)	Aluminium	On lateral point of lift&slide systems, coupled to the lock	Screws 4,5x45 mm
2	Pre-drilled locking profile (3 suitable seats) Note. Not suitable for striker with signal system.			
3	Pre-drilled locking profile (3 suitable seats, the one in the middle for striker with signal system) Note. The central housing is suitable for striker with signal system.			
4	Locking profile extension Installed above the locking profile, it allows the extension of the application field and the addition of a locking point.			

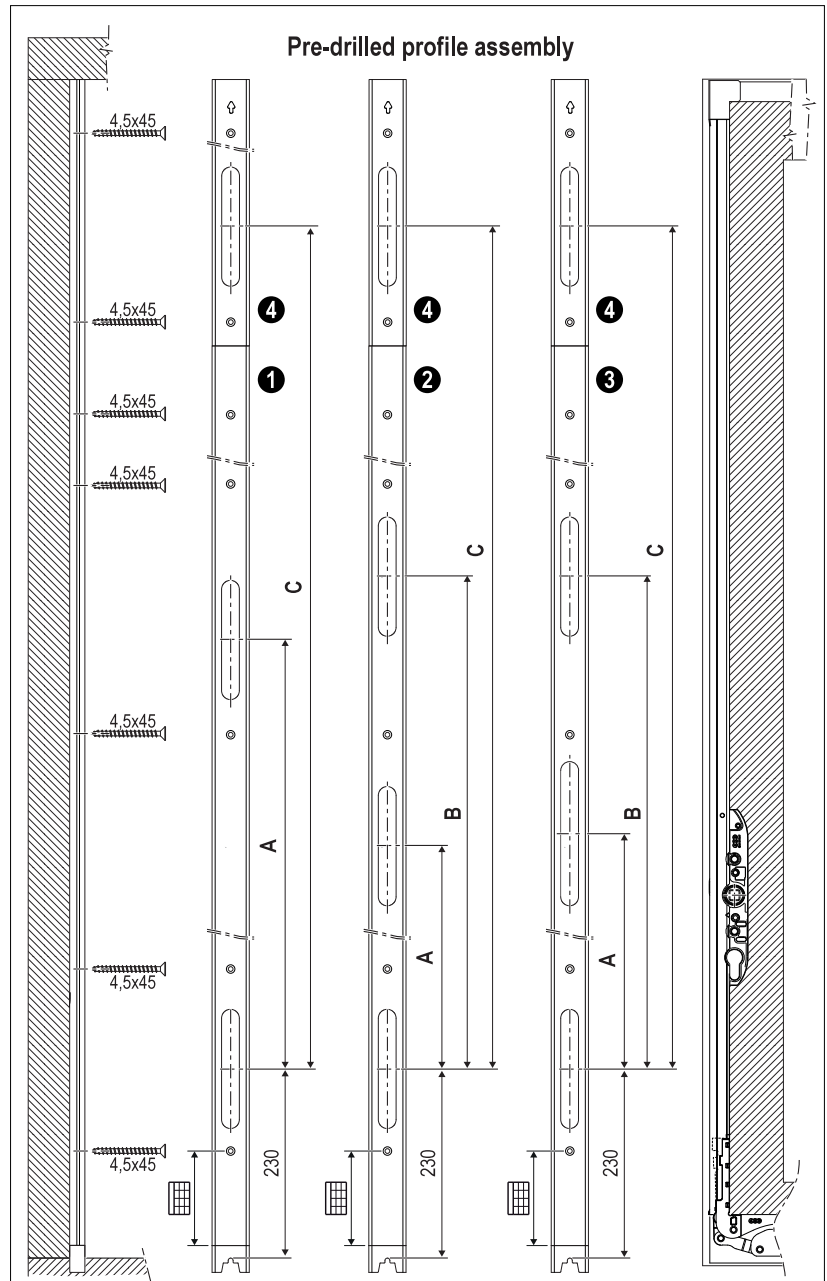
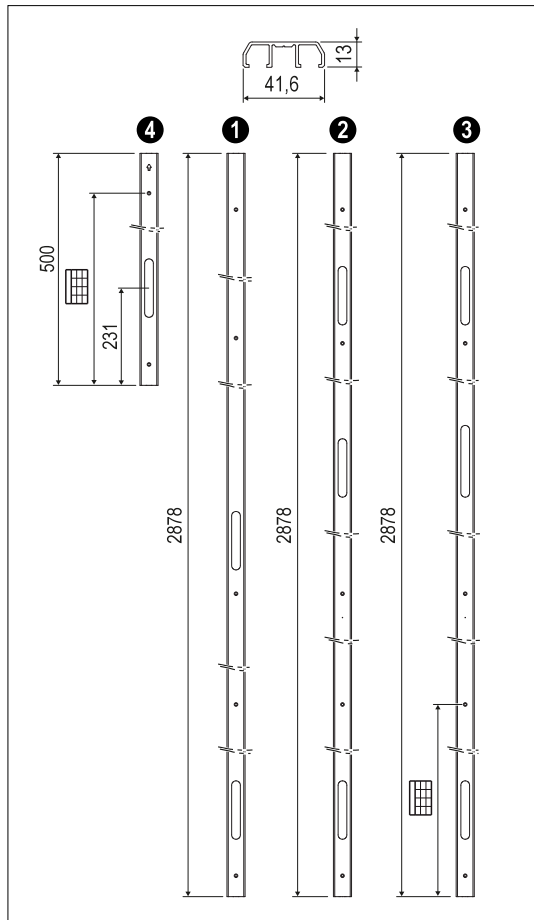

Locking points position					
	GR	Locking profile height	A	B	C (min - max)
1	3	2878	1354	-	1789,5+2137,5
	4	2878	1504	-	1939,5+2387,5
	5	2878	1904	-	2339,5+2737,5
2	3	2878	970	1354	1789,5+2137,5
	4	2878	970	1504	1939,5+2387,5
	5	2878	970	1904	2339,5+2737,5
3	3	2878	1042,6	1354	1789,5+2137,5
	4	2878	1042,6	1504	1939,5+2387,5
	5	2878	1042,6	1904	2339,5+2737,5

Article	GR	Article code, in Silver	Article code, in Electrocolour	Length	SH	Suitable seats for striker
1	3	G01359.03.01	G01359.03.02	2878	1770-2900	2
	4	G01359.04.01	G01359.04.02			
	5	G01359.05.01	G01359.05.02			
2	3	G01359.13.01	G01359.13.02	2878	1770-2900	3
	4	G01359.14.01	G01359.14.02			
	5	G01359.15.01	G01359.15.02			
3	3	G01359.23.01	G01359.23.02	2878	1770-2900	2+1
	4	G01359.24.01	G01359.24.02			
	5	G01359.25.01	G01359.25.02			
4	-	G01360.01.01	G01360.01.02	500	2900+500	1

Screw holes position						
	GR	1°	2°	3°	4°	5°
1	3	48	748	1448	2148	2718
2	4	48	748	1448	2148	2718
3	5	48	748	1448	2018	2718
4	-	128	338	-	-	-

Pin holder profile for lateral point

Article	Description	Material	Use	Fastening
Pre-drilled locking profile	Pin holder profile in anodised aluminium with suitable holes for pins housing. Caps for unused holes.	Aluminium	Lateral point of Lift&Slide systems coupled to the lock.	4,5x45 mm screws

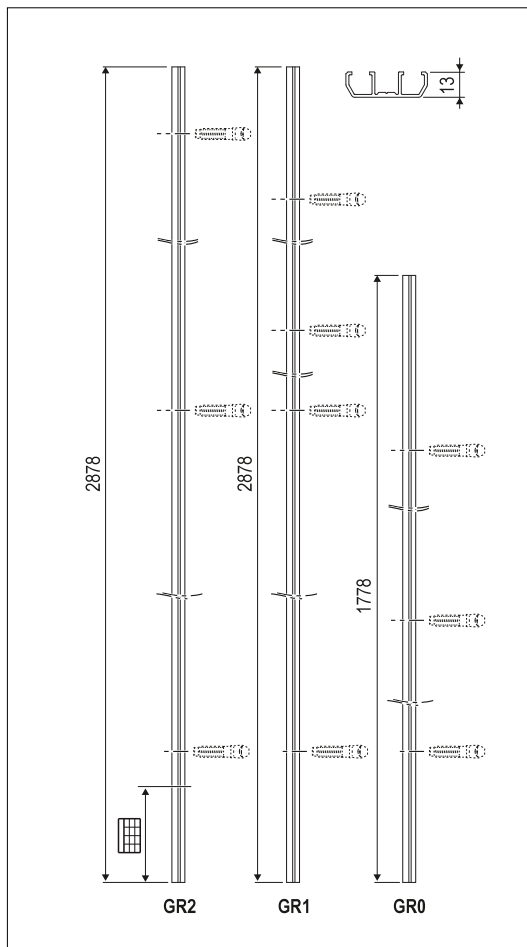

Screw holes position					
GR	1°	2°	3°	4°	5°
0	48	748	1448		
1	48	748	1448	2148	2718
2	160	730	1430	2130	2830

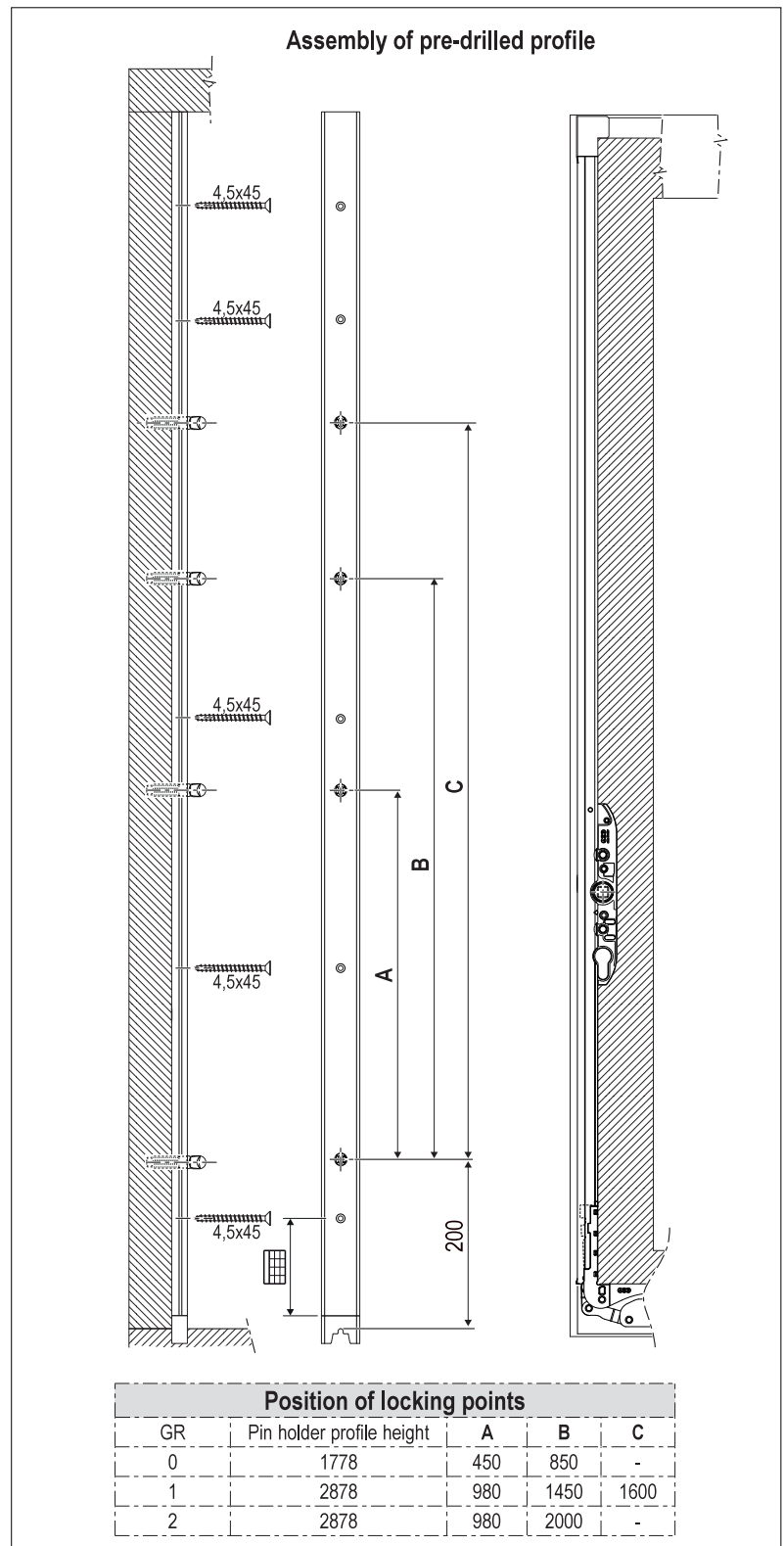

Article	GR	Article code, in Silver	Article code, in Electrocolour	Length	SH
Pre-drilled locking profile	0	For lock GR1 and GR2	G01341.00.01 / G01341.00.02	1778	800-1800
	1	For lock GR3 and GR4	G01341.01.01 / G01341.01.02	2878	1770-2900
	2	For lock GR5	G01341.02.01 / G01341.02.02	2878	1770-2900

Locking profile pins for coaxial sashes and dedicated extensions

Article	Description	Material	Use	Fastening
Locking profile kit for coaxial sashes with end caps	① Locking profile with pre-assembled anti-burglar pins. Thanks to specific end caps (lower and upper), it ensures the perfect insulation in critic areas of systems with coaxial sashes (low side and high side of central point). It replaces the wooden clamp with a great time saving for window workings.	Profile: aluminium Pins: steel	On systems with coaxial sashes.	Screws 4,5x60 mm. The position of profile screw holes coincide exactly with lock screw holes which are free.
Locking profile extension for coaxial sashes	② Extension for locking profile available with or without pin.			

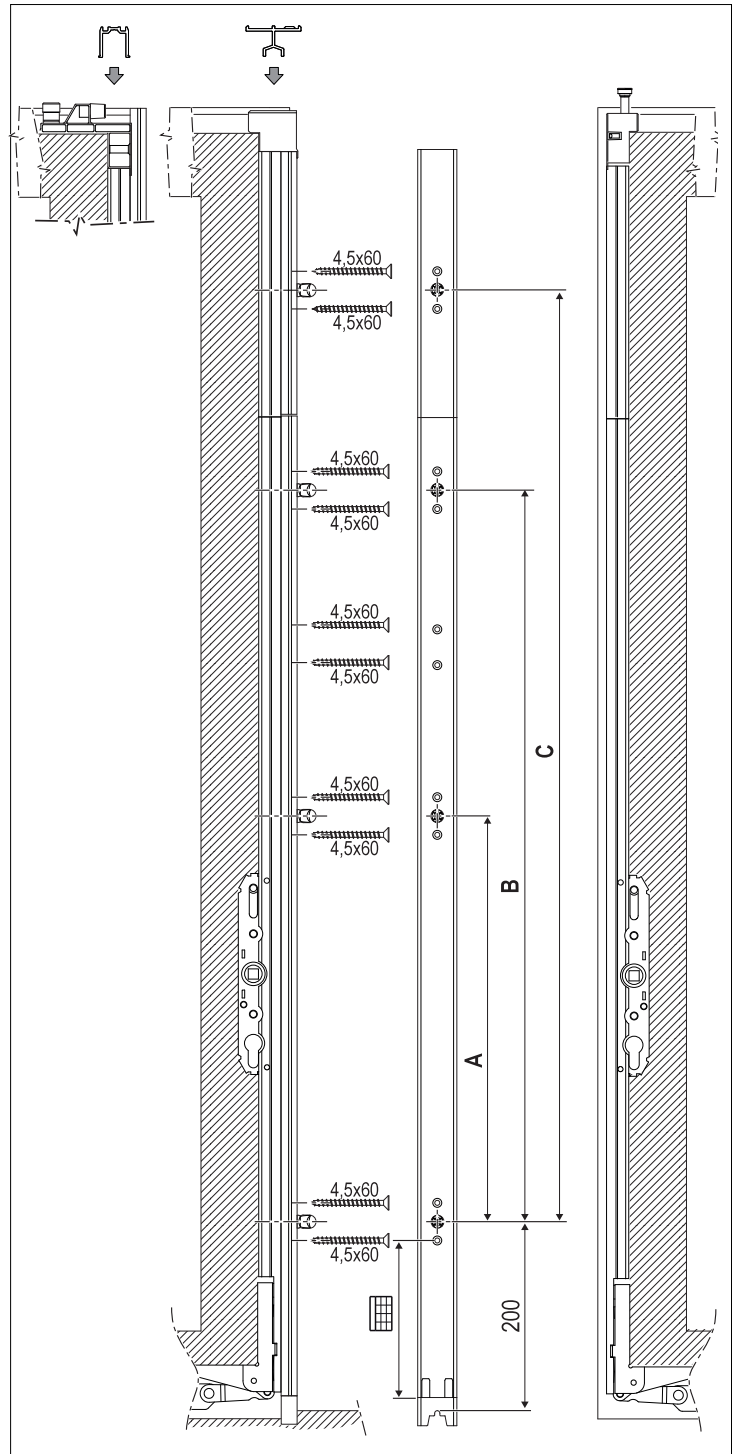
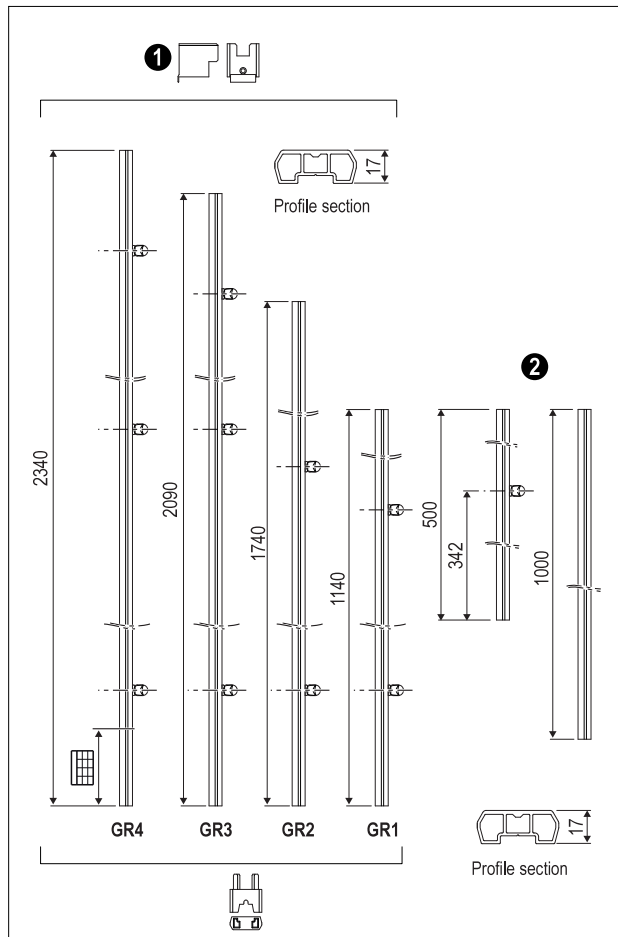

Screw holes positioning								
GR	1°	2°	3°	4°	5°	6°	7°	8°
1	132	232	294	512	582	682		
2	132	232	294	512	982	1082		
3	132	232	832	894	1112	1212	1582	1682
4	132	232	832	894	1112	1212	1732	1832

Position of locking points				
GR	Pin holder profile height	A	B	C *
1	1140	450	-	783,5-1283,5
2	1740	850	-	1183,5-1883,5
3	2090	980	1450	1783,5-2233,5
4	2340	980	1600	1933,5-2483,5

* Achievable only with 500 mm extension

Article	GR	Article code, in Silver	Article code, in Electrocolour	SRH	Handle height	Lock height
① Locking profile kit for coaxial sashes with end caps	1	G01757.01.01	G01757.01.02	810-1200	400/410	1124
	2	G01757.02.01	G01757.02.02	1170-1800	400/410	1724
	3	G01757.03.01	G01757.03.02	1770-2150	1000/1010	2074
	4	G01757.04.01	G01757.04.02	1920-2400	1000/1010	2324

Ref.	Article	Article code, in Silver	Article code, in Electrocolour	Length
②	Extension with pin	G01757.97.01	G01757.97.02	500
	Extension without pin	G01757.00.01	G01757.00.02	1000

Gas spring kit and sensors

Article	Ref.	Description	Use	Fastening
Gas spring kit	1	Gas cylinder that helps the sash opening movement (lifting) and reduce the speed of the handle.	Apply in suitable holes into the movable rod and in the aluminium profile of the lock. Please use with sashes of weight ≥ 200 Kg.	Screws are provided. Note. Please assemble the gas spring with lock in opening position and lying spring.
Sensors	2	Magnet and sensor for the control of opening.	Apply the magnet in the suitable hole of the movable rod and the sensor in the hole to realise the pin holder profile.	To joint
Magnet	3	Magnet with clip for lock.	Apply the magnet in the dedicated hole of the movable rod.	With clip

Gas spring installation

Fasten the carriages and the connecting rod to the carriages.
Unlock the carriages and put them in opening position.
Assemble the lock (with gas spring) in opening position.

1

2

3

Place the kit in specific holes under the handle

Identification of dedicated holes

Assembly order **1**

Installation of reed sensors

Find the point where the sensor and the magnet have to be installed

Please make a hole Ø12 mm (aluminium pin holder profile)

Please make a hole Ø12 mm (wooden pin holder profile)

2

Reed sensor

2

Reed sensor

3

Magnet holder with clip

3

Magnet holder with clip

Ref.	Article	Article code
1	Gas spring kit	GMG702.04.00

Ref.	Article	Article code	Colour
2	Sensor + cap	G05006.00.86	Grey
		G05006.00.93	Black

Ref.	Article	Article code
3	Magnet on clip	G05003.00.00

440 Kg locks and specific extensions

Article	Ref.	Description	Material	Use	Fastening
Locks, 440 Kg	❶	10 mm handle hub with radius corner, hole for European cylinder housing.	Forend: aluminium Rod: steel	Choose the lock according to the jamb width and the sliding sash height. Backsets available: 27,5 and 37,5 mm in 5 different heights (see the table).	4,5x45 mm screws ★ For Imago+ use 4,5x40 mm
Lock extension	❷	-	Forend: aluminium Rod: steel	It gives the possibility to add a locking point.	4,5x45 mm screws ★ For Imago+ use 4,5x40 mm
Covering profile	❸	-	Aluminium	It covers the milling.	4,5x45 mm screws ★ For Imago+ use 4,5x40 mm

Screw hole position								
GR	1°	2°	3°	4°	5°	6°	7°	8°
1	17	100,5	208,5	480,5	550,5	658,5		
2	17	100,5	208,5	480,5	950,5	1058,5		
3	17	100,5	208,5	808,5	1080,5	1188,5	1550,5	1658,5
4	17	100,5	208,5	808,5	1080,5	1188,5	1700,5	1808,5
5	17	100,5	208,5	808,5	1080,5	1188,5	2100,5	2208,5

❷

❸

Backset 27,5

Backset 37,5

440 Kg locks and specific extensions

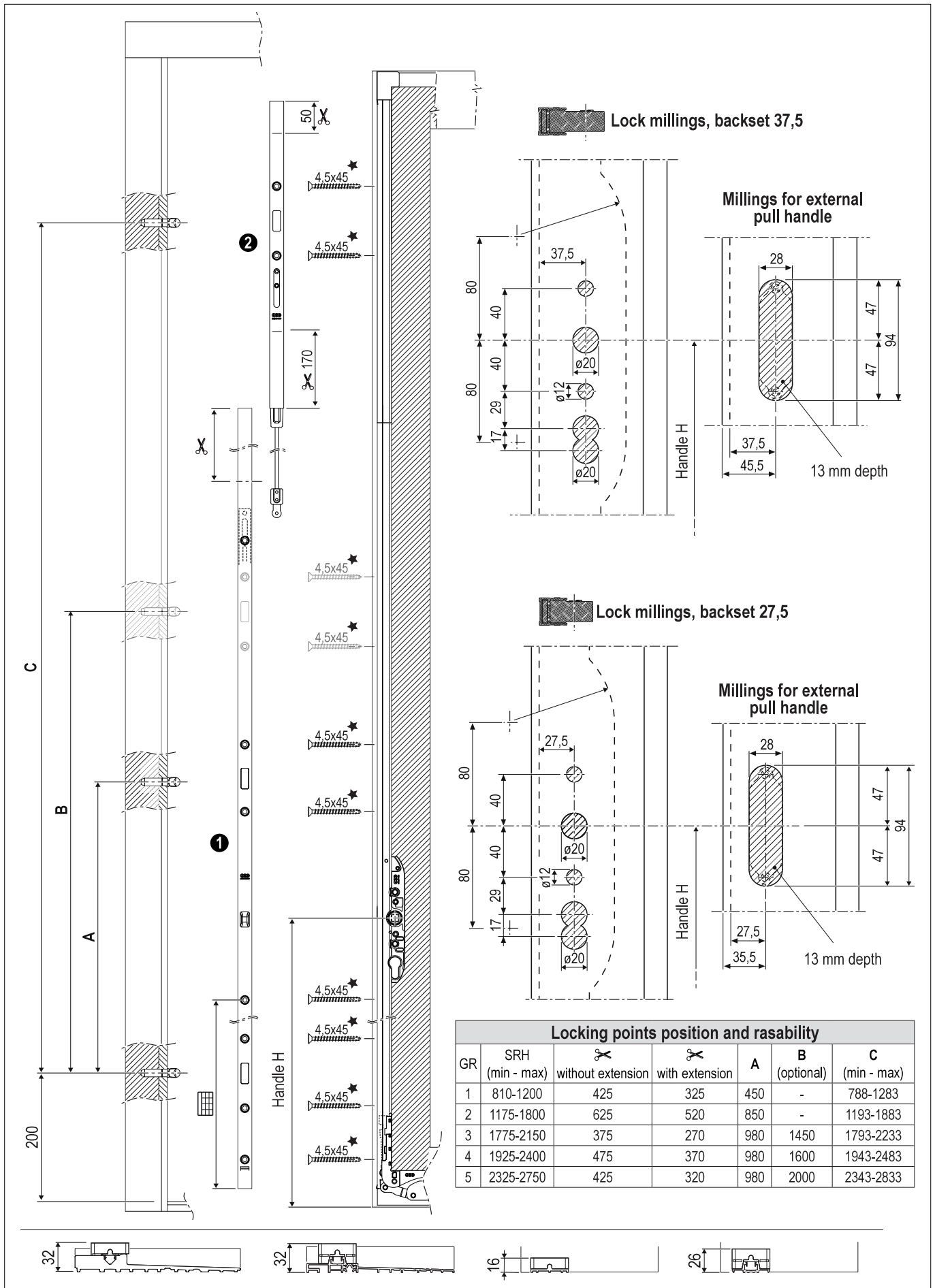

440 Kg locks and specific extensions

Ref.	Article	GR	Article code, in Silver	Article code, in Electrocolour	SRH ◊	Handle height	Lock height
❶	Lock 440 Kg Backset 27,5	1	G04027.01.01	G04027.01.02	810-1200	400/410	1096
		2	G04027.02.01	G04027.02.02	1175-1800	400/410	1696
		3	G04027.03.01	G04027.03.02	1775-2150	1000/1010	2046
		4	G04027.04.01	G04027.04.02	1925-2400	1000/1010	2296
		5	G04027.05.01	G04027.05.02	2325-2750	1000/1010	2646
	Lock 440 Kg Backset 37,5	1	G04037.01.01	G04037.01.02	810-1200	400/410	1096
		2	G04037.02.01	G04037.02.02	1175-1800	400/410	1696
		3	G04037.03.01	G04037.03.02	1775-2150	1000/1010	2046
		4	G04037.04.01	G04037.04.02	1925-2400	1000/1010	2296
		5	G04037.05.01	G04037.05.02	2325-2750	1000/1010	2646

◊ With upper guide 22x22 cod. G01002.XX.XX, the SRH application field will be reduced up to 10 mm.

Ref.	Article	Article code, in Silver	Article code, in Electrocolour	Length
❷	Extension with locking point	G04401.01.01	G04401.01.02	500
❸	Covering profile	G04401.02.01	G04401.02.02	1000

440 Kg hook locks and specific extensions

Article	Ref.	Description	Material	Use	Fastening
Locks, 440 Kg	1	10 mm handle hub with radius corner, hole for European cylinder housing.	Forend: aluminium Rod: steel Hooks: steel	Choose the lock according to the jamb width and the sliding sash height. Backsets available: 27,5 and 37,5 mm in 3 different heights (see the table).	4,5x45 mm screws ★ For Imago+ use 4,5x40 mm
Lock extension	2	-	Forend: aluminium Rod: steel Hooks: steel	It gives the possibility to add a locking point.	4,5x45 mm screws ★ For Imago+ use 4,5x40 mm
Covering profile	3	-	Aluminium	It covers the milling.	4,5x45 mm screws ★ For Imago+ use 4,5x40 mm

GR5 GR4 GR3

Screw hole position								
GR	1°	2°	3°	4°	5°	6°	7°	8°
3	17	100,5	304,5	808,5	1080,5	1274,5	1458,5	1658,5
4	17	100,5	304,5	808,5	1080,5	1274,5	1608,5	1808,5
5	17	100,5	304,5	808,5	1080,5	1274,5	2008,5	2208,5

Backset 27,5

Backset 37,5

440 Kg hook locks and specific extensions

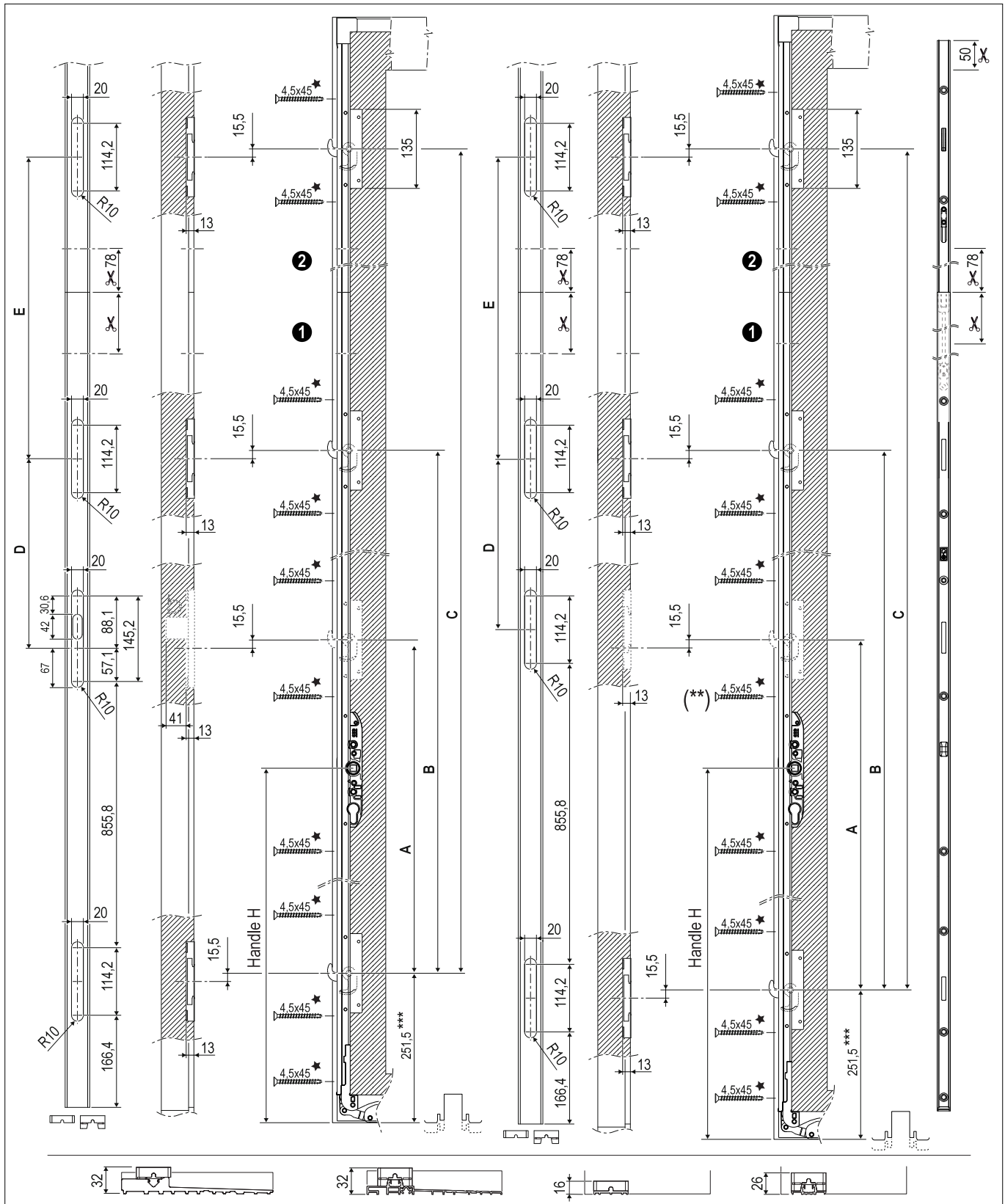

Locking points position and rasability									
	GR	SRH (min - max)	✂		A (optional)	B	C (min - max)	D	E*
			without extension	with extension					
Without signal system	3	1775-2150	375	270	970	1354	1789,5+2137,5	384	C - B
	4	1925-2400	475	370	970	1504	1939,5+2387,5	534	C - B
	5	2325-2750	425	320	970	1904	2339,5+2737,5	934	C - B
With signal system	3	1775-2150	375	270	970	1354	1789,5+2137,5	384	C - B
	4	1925-2400	475	370	970	1504	1939,5+2387,5	534	C - B
	5	2325-2750	425	320	970	1904	2339,5+2737,5	934	C - B

* For rasability check instructions Z90322.14.81

** In case of optional hook use, pre-drill for the screw.

*** In case of a high rail use, the distance is 10 mm higher.

440 Kg hook locks and specific extensions

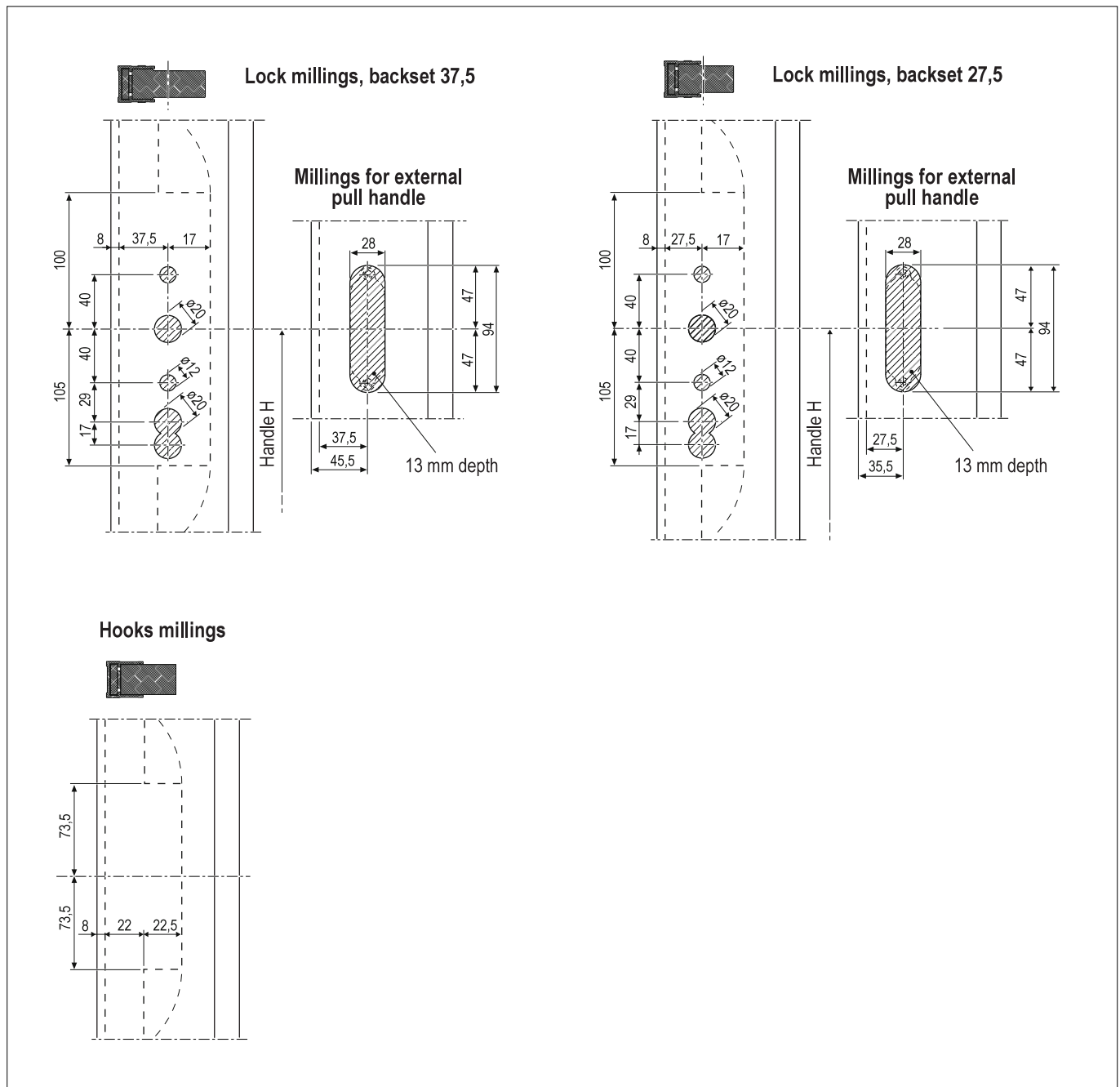

Ref.	Article	GR	Article code, in Silver	Article code, in Electrocolour	SRH \diamond	Handle height	Lock height
❶	Lock 440 Kg Backset 27,5	3	G03927.03.01	G03927.03.02	1775-2150	1000/1010	2046
		4	G03927.04.01	G03927.04.02	1925-2400	1000/1010	2296
		5	G03927.05.01	G03927.05.02	2325-2750	1000/1010	2646
	Lock 440 Kg Backset 37,5	3	G03937.03.01	G03937.03.02	1775-2150	1000/1010	2046
		4	G03937.04.01	G03937.04.02	1925-2400	1000/1010	2296
		5	G03937.05.01	G03937.05.02	2325-2750	1000/1010	2646

\diamond With upper guide 22x22 cod. G01002.XX.XX, the SRH application field will be reduced up to 10 mm.

Ref.	Article	Article code, in Silver	Article code, in Electrocolour	Length
❷	Extension with locking point	G04600.01.01	G04600.01.02	500
❸	Covering profile	G04401.02.01	G04401.02.02	1000

Rails

Article	Ref.	Description	Material	Use	Fastening
Low rail	1	Guide profile in anodized aluminium for carriages sliding	Alluminium	To be used in sliding systems when they are sheltered from the pouring rain where the amount of space has to be reduced.	Screws 3,5x40 mm with ø6 mm plug
High rail	2			<p>To be used in sliding systems when they are sheltered from the pouring rain where the amount of space has to be reduced.</p> <p>It allows a better water tightness compared to the low rail.</p>	

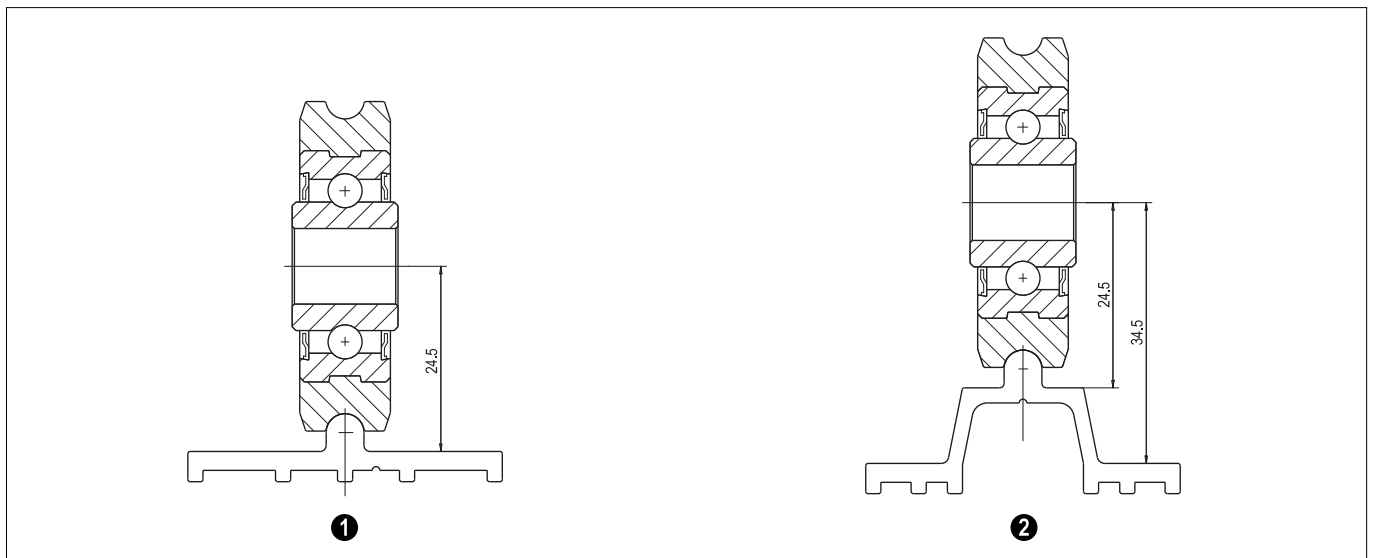

Ref.	Description	Silver	Aluminium Black	Length
1	Low rail	G00738.01.01	G00738.01.02	3000
		G00738.02.01	G00738.02.02	4000
		G00738.03.01	G00738.03.02	6000
2	High rail	G00739.01.01	G00739.01.02	3000
		G00739.02.01	G00739.02.02	4000
		G00739.03.01	G00739.03.02	6000

Hooks

Article	Ref.	Description	Material	Use	Fastening
Additional hook	1	Element with steel hook that can be placed to the lock in the defined position.	Steel and zamak	To add a locking point to the lock	Using the elastic plug supplied, on suitable holes to the lock
Additional hook with microventilation position	2	Element with steel microventilation hook that can be placed to the lock in the defined position.		It ensures the microventilation allowing to pull close the sash to the frame and blocking it in that position	

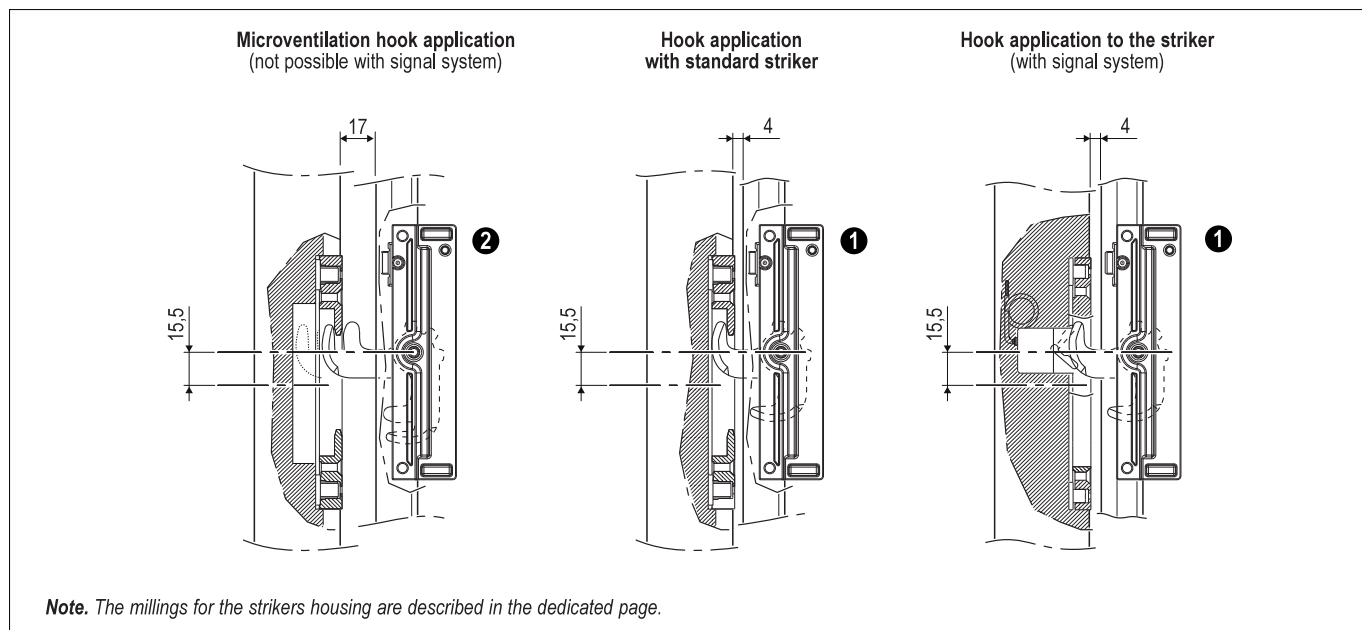
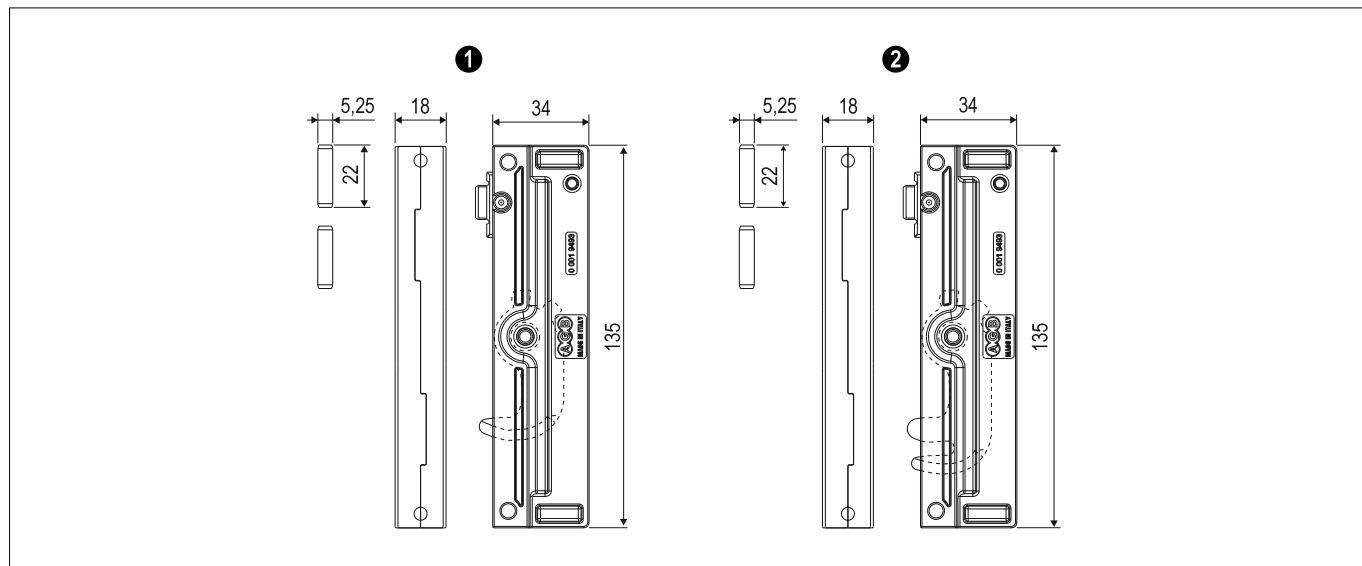

Ref.	Description	Article
1	Additional hook	G05008.00.00
2	Additional hook with microventilation position	G05010.00.00

Locking pins

Article	Ref.	Description	Material	Use	Fastening
Locking pins	1	Steel threaded pins.	Steel	Fastened to the jamb of the frame, they block the sliding sashes. They are available for wood or PVC and aluminium.	<p>ø10 mm pre-hole for soft wood. ø11 mm pre-hole for hard wood.</p> <p>Fasten the pin using the suitable hook G00746.00.06.</p> <p>Attention: don't use the hammer as it will compromise the pin tightness.</p> <p>Note. To determine the placement of locking pin, please use the jig art. G00746.00.05 (see the chapter "Jigs").</p>
Anti-burglar locking pins	2	Steel threaded pins.			
Pin with ventilation position	3	Threaded pin with double locking position. It allows to close the sash to the frame with a split for ventilation.			

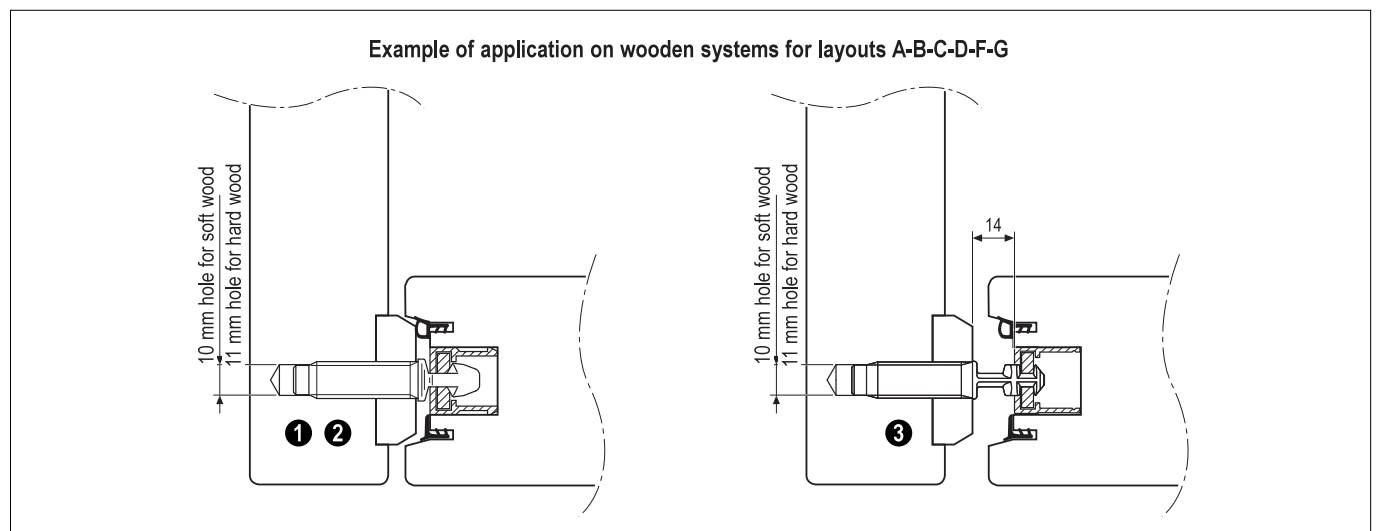
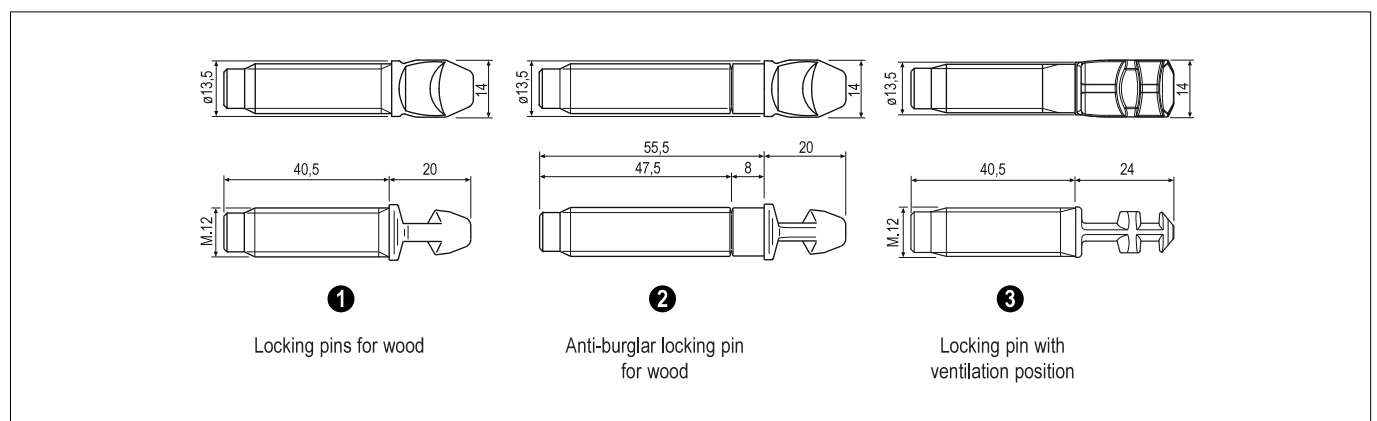

Ref.	Description	Article
1	Wood	G40728.00.03 *
2	Anti-burglar for wood	G40728.00.33 *
3	Ventilation for PVC / Aluminium-wood / Wood	G04902.01.00 *

* **Note.** Not included in the standard kit (to be ordered separately).

Uni-V central point kit

Description

Universal central point kit for all the AGB sliding systems.

Use

The use of Uni-V central point offers many advantages:

- it binds the sashes in closing position;
- keeps the production fast because it doesn't need gasket holder profiles;
- helps the system tightness thanks to the increased gasket;
- helps the sash sliding thanks to wide working tolerances which are able to compensate the natural deformation of wood.

Fastening

- Cut the components (follow the technical manual indications for each sliding system);
- insert the gasket;
- insert the terminal caps;
- fasten the profiles to sashes using screws $\varnothing 3,5 \times 35$;
- insert the screws covering profiles and the brush;
- silicone and cut following the indications of the specific technical manual for each sliding system.

Materials

- EPDM gasket,
- Covering profiles of screws in PVC,
- Extruded aluminium profiles,
- Polypropylene brush.

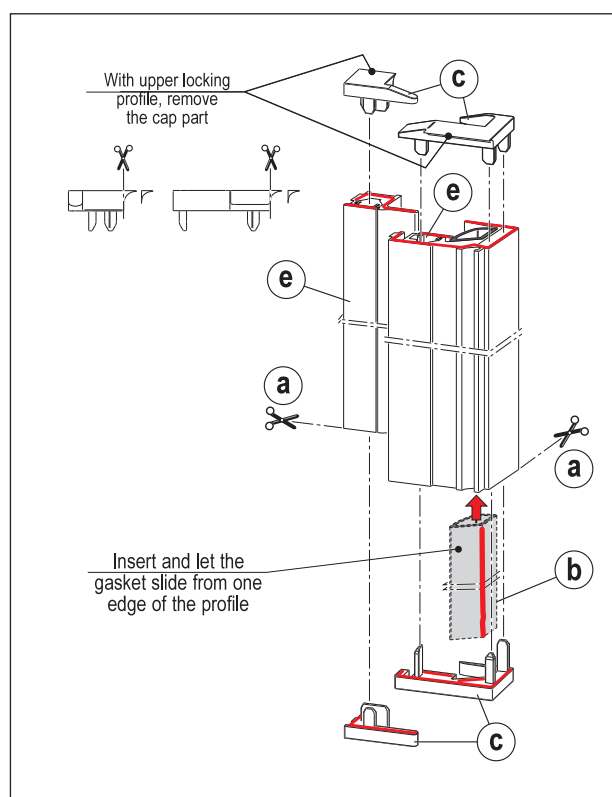
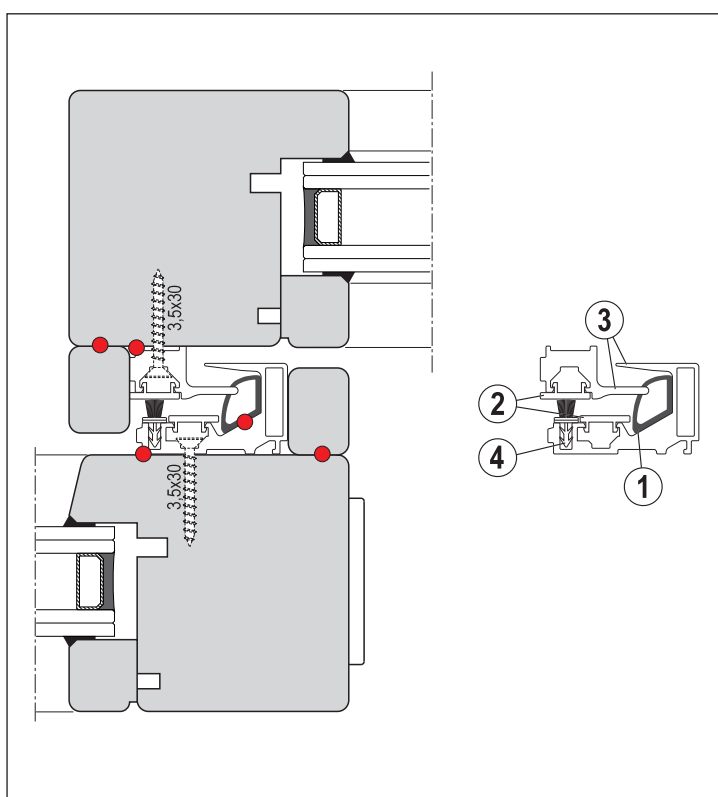

Ref.	Article	Article code	Finish	Length
1	Uni-V point profile	G02208.25.01	Silver	2500 mm
		G02208.25.93	Black	2500 mm
		G02208.31.01	Silver	3100 mm
		G02208.31.93	Black	3100 mm
		G02208.40.01	Silver	4000 mm
		G02208.40.93	Black	4000 mm

Ref.	Article	Article code	
2	Caps kit	G01610.DX.93	Right
		G01610.SX.93	Left

Central point kit Uni-V mini

Article	Ref.	Description	Use	Fastening
Uni-V Mini profile	❶	Standard central point designed for the application in all the AGB lift&slide systems.	The use of Uni-V Mini central point has many advantages: - it binds the sashes in closing position; - it helps the lift&slide production because it does not require gasket profiles for rebate - it helps the system tightness thanks to the increased gasket - it helps the sashes sliding thanks to great working tolerances which are able to compensate the natural deformations of wood.	a) cut the components (follow the indications of the technical manual according to the lift&slide type to be designed), b) insert the gasket, c) insert the terminal caps, d) fasten the profiles to sashes using screws $\varnothing 3,5 \times 35$, e) insert the covering profiles of screws and the brush, f) silicone and cut following the indications of the dedicated technical manual which concerns the lift&slide type to be designed.
Caps kit	❷			

Materials

- 1) EPDM gasket
- 2) PVC screws covering profiles
- 3) Extruded aluminium profiles
- 4) Polypropylene brush

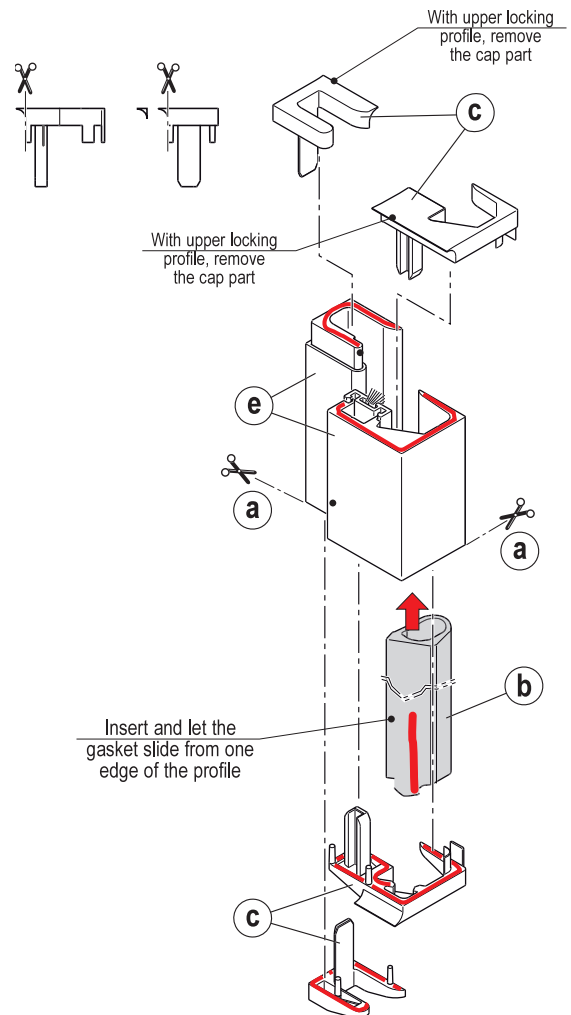
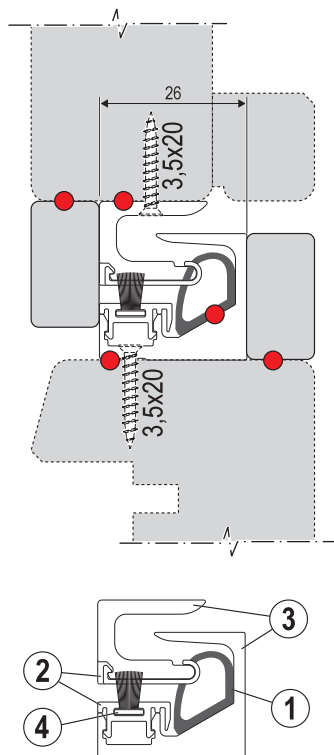

Ref.	Article	Article code	Length
❶	Uni-V Mini point profile	G02211.25.01	2500 mm
		G02211.25.93	2500 mm
		G02211.31.01	3100 mm
		G02211.31.93	3100 mm
		G02211.40.01	4000 mm
		G02211.40.93	4000 mm

Ref.	Article	Article code	
❷	Caps kit	G01623.DX.93	Right
		G01623.SX.93	Left



Alban Giacomo SpA

Sede centrale:
Via A. De Gasperi, 75
36060 Romano d'Ezzelino
(Vicenza) Italia