



Alban Giacomo SpA

COMPANY WITH
QUALITY SYSTEM
CERTIFIED BY DNV GL
= ISO 9001 =

TECHNICAL MANUAL

LIFT & SLIDE

Climatech **78/80** mm

XC Configuration

Layouts **A & E**, Layouts **B & F**

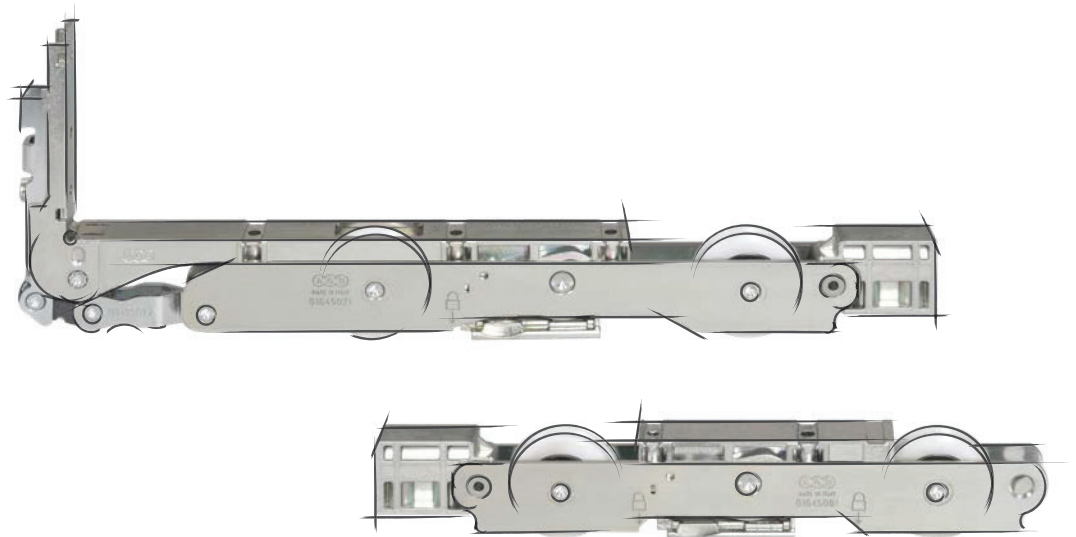

| | |
|--|----|
| INTRODUCTION | 3 |
| Warnings | 3 |
| Symbology and abbreviations | 3 |
| CONFIGURATION CHOICE AND CALCULATIONS | 4 |
| Possible layouts developed in this manual | 4 |
| Possible configurations developed in other AGB documentation | 4 |
| LAYOUTS A & E | 5 |
| Dimensions calculation of sliding sashes | 5 |
| Hardware diagram with hooks lock | 6 |
| Hardware diagram with pins lock | 8 |
| Horizontal section | 10 |
| Calculation of jambs and listels measurements | 12 |
| Vertical section A-A - Sliding sash | 13 |
| Vertical section B-B - Fixed sash | 14 |
| Millings - Vertical section, upper point | 15 |
| Millings - Vertical section, lower point | 16 |
| Millings - Horizontal section, sliding sash | 17 |
| Millings - Horizontal section, fixed sash | 18 |
| Millings - Central point horizontal section, coaxial sashes | 19 |
| Formulas of accessories cut | 20 |
| LAYOUTS B & F | 21 |
| Calculation of sliding sashes dimensions | 21 |
| Hardware diagram with hooks lock | 22 |
| Hardware diagram with pins lock | 24 |
| Horizontal section | 26 |
| Vertical section | 28 |
| Cut and positioning of upper pad | 28 |
| Wood millings: horizontal section of frame jamb - (Scale 1:1) | 29 |
| Wood millings: vertical section of upper frame transom - (Scale 1:1) | 29 |
| Details for layouts B & F | 30 |
| Formulas for accessories cut | 31 |
| LAYOUTS A & E, LAYOUTS B & F - ASSEMBLY OPERATIONS | 32 |
| Threshold fastening | 32 |
| Caps application under the jambs | 32 |
| Pad application on central jambs | 32 |
| Positioning of central profile and point on sliding sash - layouts E-F | 33 |
| Lock holes | 33 |
| Accessories for single sash configuration with guide 22x22 | 34 |
| Accessories for single sash configuration with guide 22x13 | 35 |
| Accessories for coaxial sashes configuration with guide 22x13 | 36 |
| Accessories for coaxial sash configuration with guide 22x22 | 37 |
| Sash assembly | 38 |
| Locking pins assembly | 38 |
| Use of gas spring kit | 39 |
| STEPS FOR THE PRODUCTION PROCESS CONTROL (FPC) | 40 |
| TECHNICAL ATTACHMENTS | 41 |

INTRODUCTION

Warnings



















Possible changes regarding accessories, assembly and millings will be constantly reported with the periodic update of this manual. Therefore, we suggest to pay attention to the release of new versions in the website www.agb.it.



The producers who use the AGB Certification agreement must install glasses with the following minimum requirements:
Minimum thickness 44.1/15/33.1 Shatterproof

Symbology and abbreviations

| | | |
|--|---|-------------------------------|
| HB | = | Sash height |
| LB | = | Sash width |
| MET | = | Frame external measurement |
| SMT | = | Frame jamb thickness |
| SMA | = | Sash jamb thickness |
| LBF | = | Fixed sash width |
| HET | = | Frame external height |
| STST | = | Frame upper transom thickness |
| LG | = | Glass width |
| HG | = | Glass height |
| H | = | Component height |
| L | = | Component length |
| Gap | = | 5 mm |
|  | = | Silicone or suitable gasket |
|  | = | Neutral silicone with Primer |
|  | = | Pre-hole |
|  | = | EPDM tape |

| | | |
|---|-----------|---|
|  | = | Solution detail with high/reduced upper guide |
|  | = | Solution detail with guide 22X13 |
|  | = | Solution detail with guide 22X22 |
|  | = | Detail solution with XC carriages |
|  | = | Detail solution with XC S-Line carriages |
|  | = | Detail solution with hooks lock |
|  | = | Detail solution with pins lock |
|  | = | Solution with Uni-V central point |
|  | = | Solution with basic point |
|  | = | Solution with central point Easy |
|  | = | Solution with Uni-V Mini central point |
|  | 23 | = Reference page number for details |

Note. All the measurements are in millimeters

Note. Quotas related to the version "80 mm" are indicated in brackets

CONFIGURATION CHOICE AND CALCULATIONS

Possible layouts developed in this manual

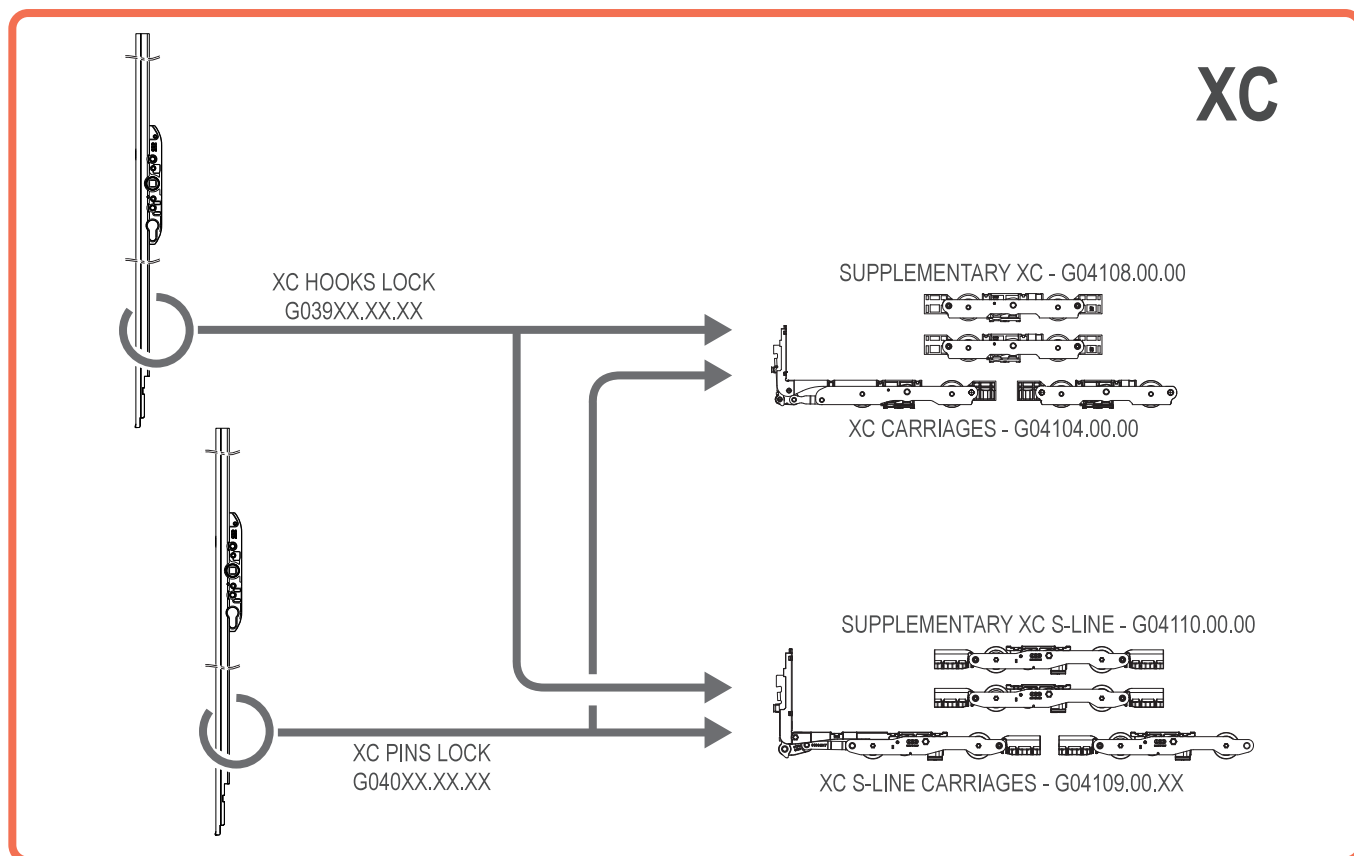

LAYOUTS A & E

- Sash with one transom in the lower part with possibility to have a basement.
- Vertical external gasket - lower: balloon with vulcanized edge in EPDM.
- Covering internal side gasket of the milling in EPDM.
- PVC upper gasket with wing.
- EPDM sponge co-extruded central point gasket.
- Aluminium upper covering profile with waterproof tightness sponge.
- Water, air, wind and impact tests made in glass: 44.1/10/5/10/33.1 (minimum possible).
- Aluminium universal reduced upper guide and threshold in pultruded fiberglass.
- Distance between the sashes 28 mm.
- Layout E made with symmetric central point and aluminium pin holder profile and extremity caps for gaps closing.
- External architrave cable with brush.

Dimensions calculation of sliding sashes

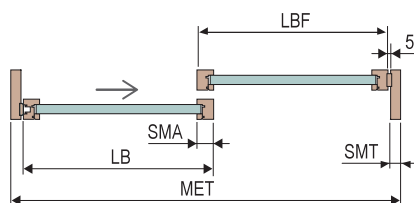
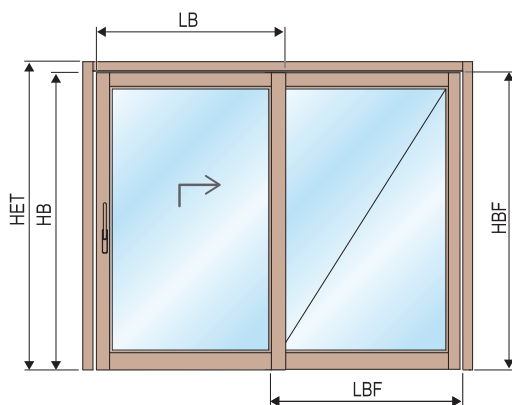

Layout A
 1 fixed sash and 1 sliding sash
 $LB = [MET - 2 \times (SMT + 5)] : 2 + SMA : 2$
 Ex: $LB = [4000 - 2 \times (45 + 5)] : 2 + 100 : 2$ $LB = 2000$ mm

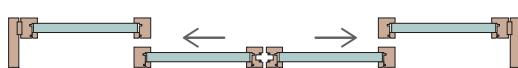

Layout E
 2 fixed sashes and 2 sliding sashes
 $LB = [MET - (2 \times SMT + 15)] : 4 + SMA : 2$



Layout D
 1 fixed sash and 2 sliding sashes
 $LB = [MET - 2 \times (SMT + 5)] : 4 + SMA : 2$

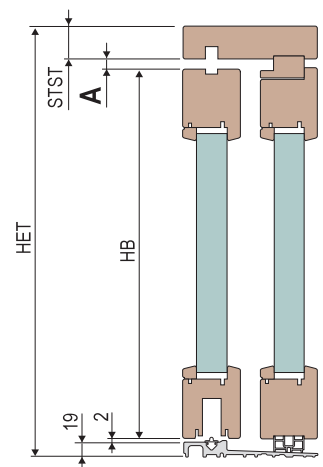

A = 12
 $\Rightarrow HB = HET - (STST + 12 + 21)$

A = 15 (guide 22x22)
 $\Rightarrow HB = HET - (STST + 15 + 21)$

(Tolerance HB ± 0,5)

| | G1 | G2 | G3 |
|--------|----|----|----|
| A = 12 | ✓ | ✓ | ✓ |
| A = 15 | ✗ | ✗ | ✓ |

Hardware diagram with hooks lock

- 1 Hooks lock**
G039EE.03.XX HB=1775-2150 Handle H = 1000
G039EE.04.XX HB=1925-2400 Handle H = 1000
G039EE.05.XX HB=2325-2750 Handle H = 1000
- 2 Additional hook kit - G05008.00.00**
- 3 Microventil. addit. hook kit - G05010.00.00**
- 4 Hooks lock for second sash**
GR39EE.03.01 HB=1775-2150 Handle H = 1000
GR39EE.04.01 HB=1925-2400 Handle H = 1000
GR39EE.05.01 HB=2325-2750 Handle H = 1000
- 5 Hooks extension 500 mm - G04600.01.01**
- 6 Covering profile 1000 mm - G04401.02.01**
- 7 Gas spring kit - GMG702.04.00**
- 8 XC carriages basic kit - G04104.00.00**
- 9 XC supplementary carriages kit- G04108.00.00**
- 10 XC S-Line carriages kit - G04109.00.00**
- 11 XC S-Line supplementary carriages kit - G04110.00.00**
- 12 Carriages connecting rod**
G04601.00.01 L=1000 G04601.00.03 L=1800
G04601.00.02 L=1400 G04601.00.04 L=2700
- 13 Handle fastening plate**
G05371.M5.00 hole M5
G05371.M6.00 hole M6
- 14 Anti-burglar plate kit - G05004.00.00**
- 15 Sensors**
G05006.00.86 Grey
G05006.00.93 Black
G05003.00.00 Clip
- 16 Lateral locking profile for hooks lock**
G01359.03.XX GR3 predisposition 2 hooks
G01359.04.XX GR4 predisposition 2 hooks
G01359.05.XX GR5 predisposition 2 hooks
G01359.13.XX GR3 predisposition 3 hooks
G01359.14.XX GR4 predisposition 3 hooks
G01359.15.XX GR5 predisposition 3 hooks
G01359.23.XX GR3 predisp. signal system
G01359.24.XX GR4 predisp. signal system
G01359.25.XX GR5 predisp. signal system
- 17 Extens. for locking prof. for hooks lock**
G01360.01.XX L=500
- 18 Coax. sashes lock. prof. for hooks lock + caps**
G01373.13.XX L=2075 HB=1775-2150 With hook strik.
G01373.14.XX L=2325 HB=1925-2400 With hook strik
G01373.15.XX L=2750 HB=2325-2750 With hook strik
- 19 Extens. for coax. sashes lock. for hooks, 500 mm**
G01364.01.XX With hook strik.
- 20 Strik. for lock hook - G06201.00.XX**
- 21 Strik. for lock hook with sign. system - G06203.00.XX**
- 22 Comp. cap for frame jamb (A)**
- 23 Support for cap (A)**
- 24 Central pad (A)**
- 25 Cap for fixed sash supporting profile (A)**
- 26 Climatech fastening kit (A)**
- 27 EPDM gasket (A)**
- 28 Embedded upper guide 22x13**
G01000.01.XX L=3000 G01000.04.XX L=6000
G01000.02.XX L=4000 G01000.14.XX L=7000
G01000.03.XX L=5000
- 29 Shaped cap for embedd. guide 22x13 (B)**
- 30 Shaped cap for low. rail (B) (C) (F)**
- 31 Rear low. covering cap (B) (F)**
- 32 Cap and glider for front upper guide (B)**
- 33 Cap and glider for front upper guide (B)**
- 34 Red.doop stop for embed.guide - G00204.04.JJ702**
- 35 Embedded upper guide 22x22**
G01002.01.XX L=3000 G01002.04.XX L=6000
G01002.02.XX L=4000 G01002.05.XX L=7000
G01002.03.XX L=5000
- 36 Shaped cap for per embed. guide 22x22 (C)**
- 37 Front glider (C)**
- 38 Rear glider (C)**
- 39 Rear lower pad (C)**
- 40 Glider fastening device (C)**
- 41 Device (C) (E)**
- 42 Cover (C)**
- 43 Magnetic device (D) (E)**
- 44 Opening brake (D)**
- 45 Closing brake (E)**
- 46 Shaped cap for upper guide (F)**
- 47 Terminal cap for lock (F)**
- 48 Rear upper cover. cap (F)**
- 49 Reduced upper guide**
G01734.01.XX L=3000 G01734.04.XX L=6000
G01734.02.XX L=4000 G01734.14.XX L=7000
G01734.03.XX L=5000
- 50 Door stop**
G00204.00.91 White G00204.00.93 Black
G00204.00.86 Grey
- 51 Upper locking profile**
G02403.15.01 L=1500 G02403.30.01 L=3000
G02403.20.01 L=2000
- 52 Uni-V central point kit**
G02208.25.KK L=2500 G02208.40.KK L=4000
G02208.31.KK L=3100
- 53 Uni-V central point caps kit**
G01610.DX.93 Right G01610.SX.93 Left
- 54 Uni-V Mini central point kit**
G02211.25.KK L=2500 G02211.40.KK L=4000
G02211.31.KK L=3100
- 55 Uni-V Mini central point caps kit**
G01623.DX.93 Destro G01623.SX.93 Sinistro
- 56 Climatech threshold kit**
G02278.01.ZZ L=3000 G02278.04.ZZ L=6000
G02278.02.ZZ L=4000 G02278.14.86 L=7000
G02278.03.ZZ L=5000
- 57 Climatech thres. adapter for high threshold**
G01212.01.01 L=3000 G01212.04.01 L=6000
G01212.02.01 L=4000 G01212.14.01 L=7000
G01212.03.01 L=5000
- 58 Gasket for high thres. - 7 meters - G02210.01.00**
- 59 Fixed sash supporting profile**
G01302.02.93 L=2000 G01302.04.93 L=3000
- 60 Thermal profile**
G01311.02.JJ L=2000 G01311.04.JJ L=3000
- 61 PVC upper flexible gasket**
G00733.02.01 L=40 G00733.02.02 L=200
- 62 Ext. side gasket (balloon) (G)**
G020DX.09.93 - G020SX.09.93 L1500 x H2500
G02000.08.93 L3000 x H3000
- 63 Internal side gasket L150 m - G02004.15.93 (G)**
- 64 Flexible gasket for Easy point**
G00733.04.01 L=40
G00733.04.02 L=200
- 65 Brush gasket**
G02002.16.00 L=1600 G02002.31.00 L=3100
G02002.25.00 L=2500
- 66 XC anti-derailed adapt. - G01611.02.00**
- 67 Rod guide - G05102.00.00**
- 68 S-Line anti-derailed device - G01611.01.00**
- 69 S-Line rod guide - G00728.00.29**
- 70 Cover for fiberglass threshold - stainless steel**
G01220.00.08 Thickness 78
G01220.MM.08 Angled
- 71 Fastening kit for thres. cover - G01219.00.01**
- 72 Handle access. kit for thick.78 and 92**
G05390.00.00 Viti M5
G05390.01.00 Viti M6
- 73 Handle**

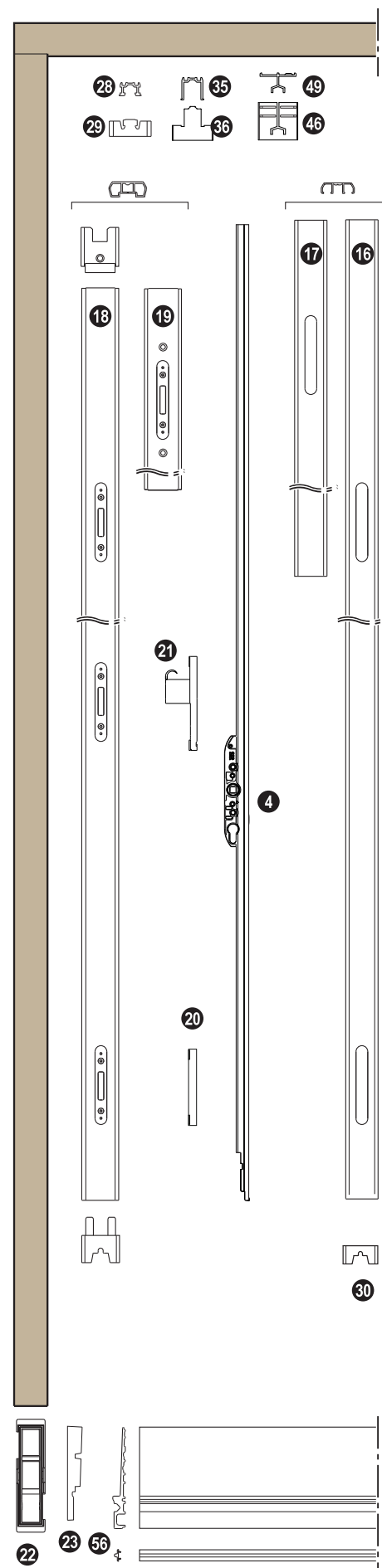

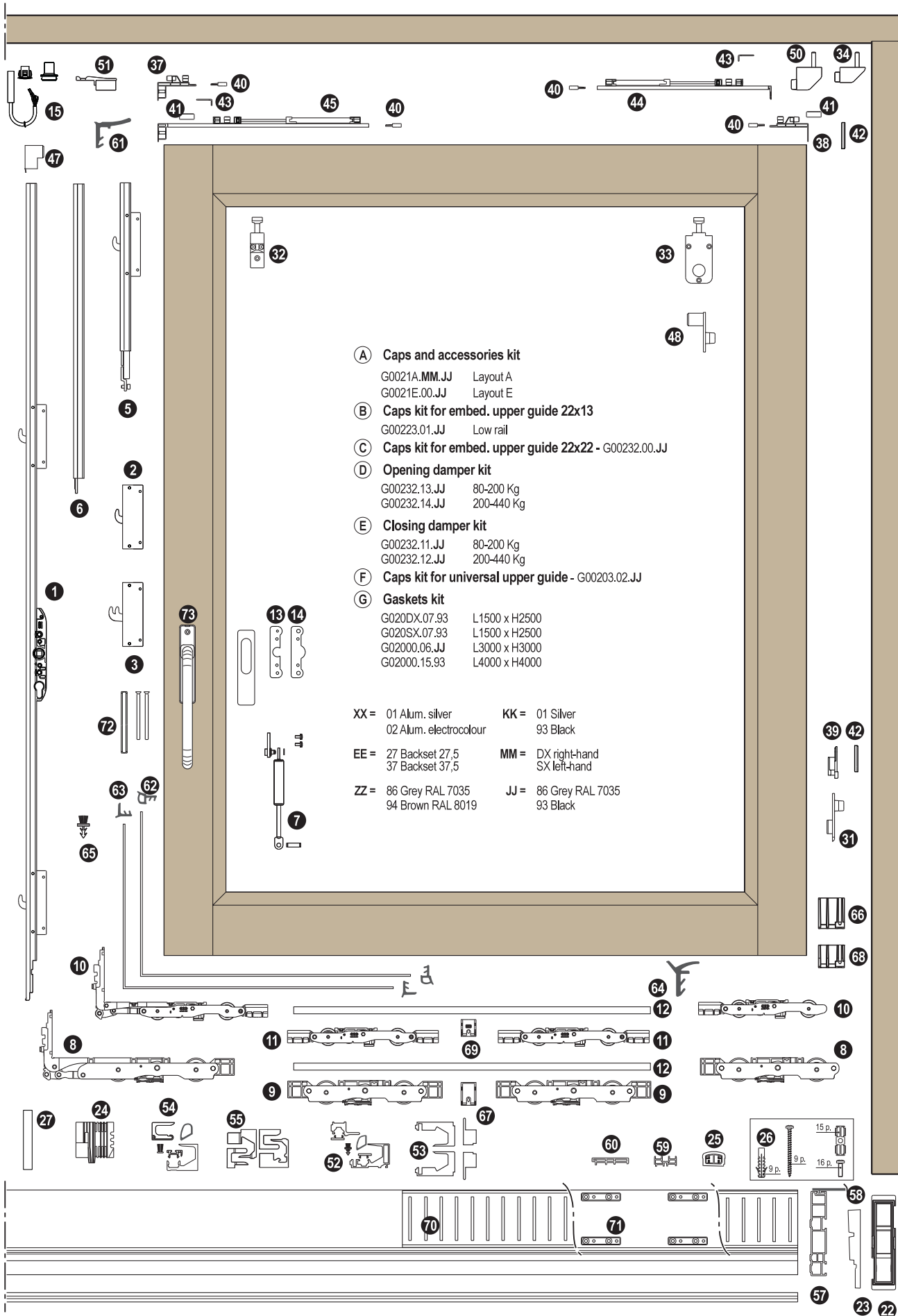

Hardware diagram with pins lock

- 1 Pins lock**
G040EE.01.XX Handle h = 400 HB=800-1200
G040EE.02.XX Handle h = 400 HB=1170-1800
G040EE.03.XX Handle h = 1000 HB=1770-2150
G040EE.04.XX Handle h = 1000 HB=1920-2400
G040EE.05.XX Handle h = 1000 HB=2401-2750
- 2 Pins extension 500 mm** - G04401.01.01
- 3 Covering profile 1000 mm** - G04401.02.01
- 4 Gas spring kit** - GMG702.04.00
- 5 XC basic carriages kit** - G04104.00.00
- 6 XC supplementary carriages kit** - G04108.00.00
- 7 XC S-Line carriages kit** - G04109.00.00
- 8 XC S-Line supplementary carriages kit** - G04110.00.00
- 9 Carriages connecting rod**
G04601.00.01 L=1000
G04601.00.02 L=1400
G04601.00.03 L=1800
G04601.00.04 L=2700
- 10 Handle fastening plate**
G05371.M5.00 hole M5
G05371.M6.00 hole M6
- 11 Anti-burglar plate kit** - G05004.00.00
- 12 Sensors**
G05006.00.86 Grey
G05006.00.93 Black
G05003.00.00 Clip
- 13 Pin holder profile for lateral point**
G01341.00.XX L=1800 HB=800-1800
G01341.01.XX L=2900 HB=1770-2900
G01341.02.XX L=2900 HB=2401-2900
- 14 Locking profile for coaxial sashes + caps**
G01361.01.XX L=1125 HB=810-1200
G01361.02.XX L=1725 HB=1175-1800
G01361.03.XX L=2075 HB=1775-2150 with caps
G01361.04.XX L=2325 HB=1925-2400
G01361.05.XX L=2750 HB=2325-2750

G01340.01.XX L=1125 HB=810-1200
G01340.02.XX L=1725 HB=1175-1800
G01340.03.XX L=2075 HB=1775-2150 with caps and
G01340.04.XX L=2325 HB=1925-2400 ventil. pin
G01340.05.XX L=2750 HB=2325-2750
- 15 Coax. sashes locking profile extens. for pins, 500 mm**
G01361.97.XX
- 16 Coax. sashes locking profile extens. for pins, 1000 mm**
G01757.00.XX
- 17 Pin**
G40728.00.03 for locking
G04902.01.00 for ventilation
- 18 Comp. cap for frame jamb** (A)
- 19 Support for cap** (A)
- 20 Central pad** (A)
- 21 Cap for fixed sash support. profile** (A)
- 22 Climatech fastening kit** (A)
- 23 EPDM gasket** (A)
- 24 Embedded upper guide 22x13**
- 25 Shaped cap for C track 22x13** (B)
- 26 Shaped cap for lower rail** (B) (C) (F)
- 27 Rear lower covering cap** (B) (F)
- 28 Cap and glider for front upper guide** (B)
- 29 Cap and glider for rear upper guide** (B)
- 30 Reduced door stop for embed.guide** - G0204.04.JJ.702
- 31 Embedded upper guide 22x22**
G01002.01.XX L=3000 G01002.04.XX L=6000
G01002.02.XX L=4000 G01002.05.XX L=7000
G01002.03.XX L=5000
- 32 Shaped cap for embedded guide 22x22** (C)
- 33 Front glider** (C)
- 34 Rear glider** (C)
- 35 Rear lower pad** (C)
- 36 Device for glider fastening** (C)
- 37 Device** (C) (E)
- 38 Cover** (C)
- 39 Magnetic device** (D) (E)
- 40 Opening brake** (D)
- 41 Closing brake** (E)
- 42 Reduced upper guide**
G01734.01.XX L=3000 G01734.04.XX L=6000
G01734.02.XX L=4000 G01734.14.XX L=7000
G01734.03.XX L=5000
- 43 Shaped cap for upper guide** (F)
- 44 Terminal cap for lock** (F)
- 45 Rear upper covering cap** (F)
- 46 Door stop**
G00204.00.91 White G00204.00.93 Black
G00204.00.86 Grey
- 47 Locking profile**
G02403.15.01 L=1500 G02403.30.01 L=3000
G02403.20.01 L=2000
- 48 Uni-V central point kit**
G02208.25.KK L=2500 G02208.40.KK L=4000
G02208.31.KK L=3100
- 49 Uni-V central point caps kit**
G01610.DX.93 Right G01610.SX.93 Left
- 50 Uni-V Mini central point kit**
G02211.25.KK L=2500 G02211.40.KK L=4000
G02211.31.KK L=3100
- 51 Uni-V Mini central point caps kit**
G01623.DX.93 Right G01623.SX.93 Left
- 52 Climatech threshold kit**
G02278.01.ZZ L=3000 G02278.04.ZZ L=6000
G02278.02.ZZ L=4000 G02278.14.86 L=7000
G02278.03.ZZ L=5000
- 53 Climatech thres. adapter for high thres.**
G01212.01.01 L=3000 G01212.04.01 L=6000
G01212.02.01 L=4000 G01212.14.01 L=7000
G01212.03.01 L=5000
- 54 Gasket for high thres. - 7 meters** - G02210.01.00
- 55 Fixed sash supporting profile**
G01302.02.93 L=2000
G01302.04.93 L=3000
- 56 Thermal profile**
G01311.02.JJ L=2000
G01311.04.JJ L=3000
- 57 External side gasket (balloon)** (G)
G020DX.09.93 - G020SX.09.93 L1500 x H2500
G02000.08.93 L3000 x H3000
- 58 Internal side gasket L150 m** - G02004.15.93 (G)
- 59 PVC upper flexible gasket**
G00733.01.01 L=40
G00733.01.02 L=200
- 60 Flexible gasket for Easy point**
G00733.02.01 L=40
G00733.02.02 L=200
- 61 Brush gasket**
G02002.16.00 L=1600
G02002.25.00 L=2500
G02002.31.00 L=3100
- 62 XC anti-derailed device** - G01611.02.00
- 63 Rod guide** - G05102.00.00
- 64 S-Line anti-derailed device** - G01611.01.00
- 65 S-Line rod guide** - G00728.00.29
- 66 Cover for fiberglass threshold - stainless steel**
G01220.00.08 Thickness 78
G01220.MM.08 Angled
- 67 Fasten kit for thres cover** - G01219.00.01
- 68 Handle access kit for 78 and 92 thick.**
G05390.00.00 screws M5
G05390.01.00 screws M6
- 69 Handle**

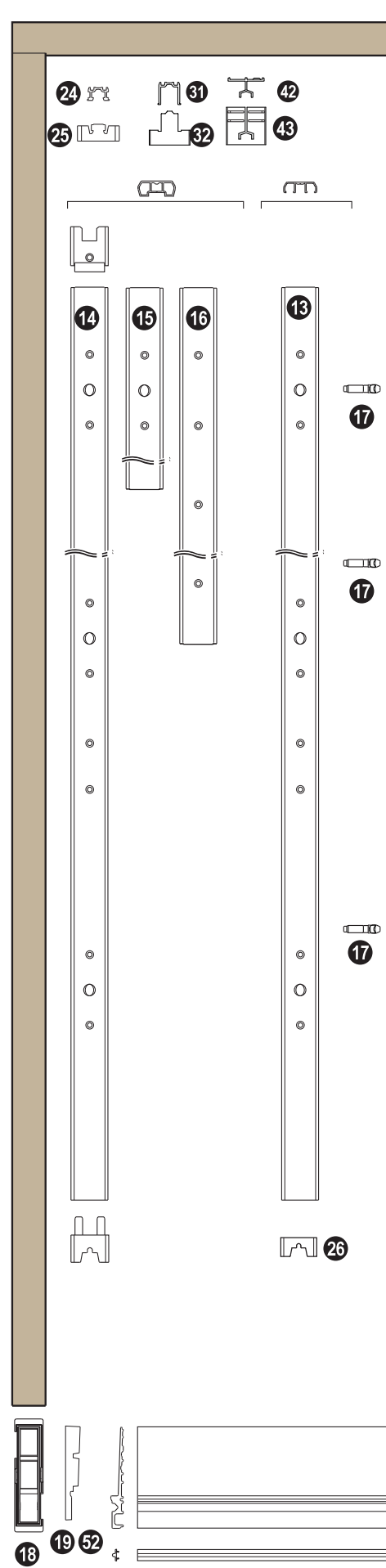

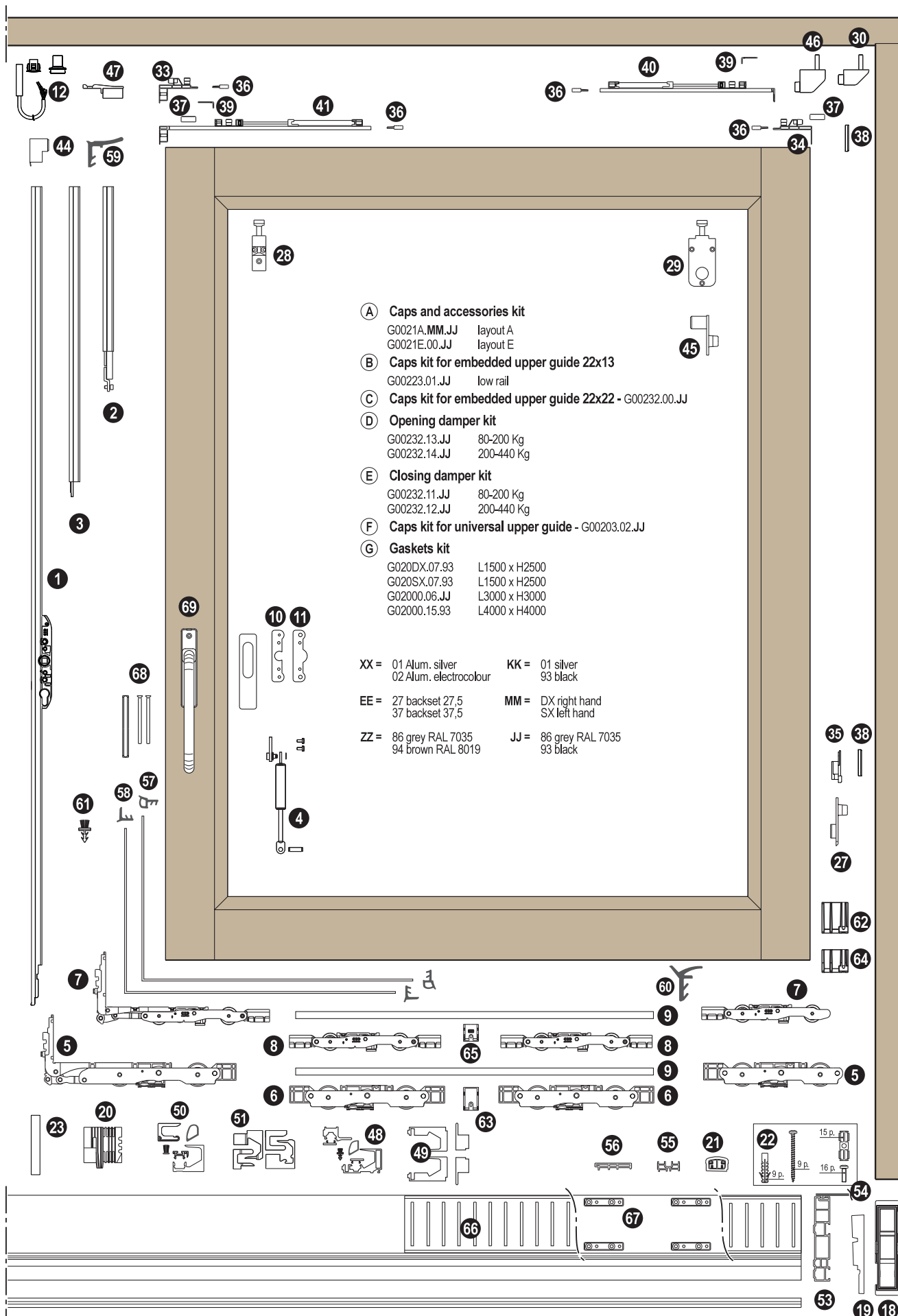

Horizontal section

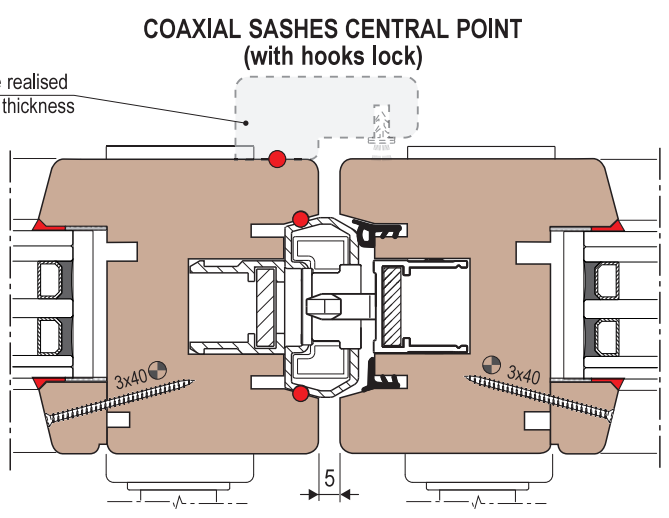
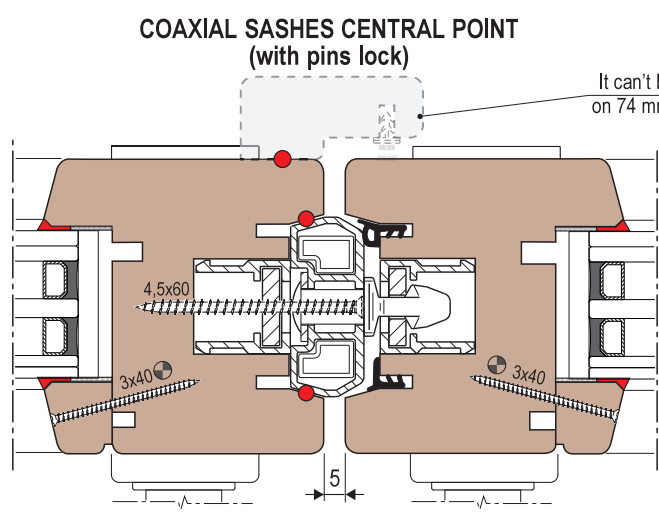
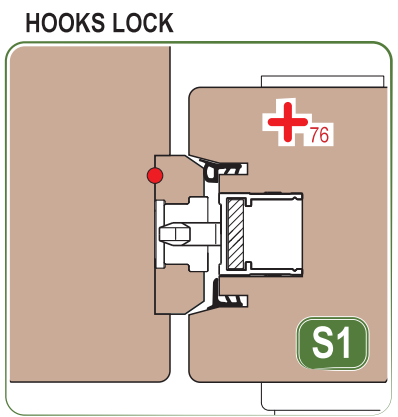
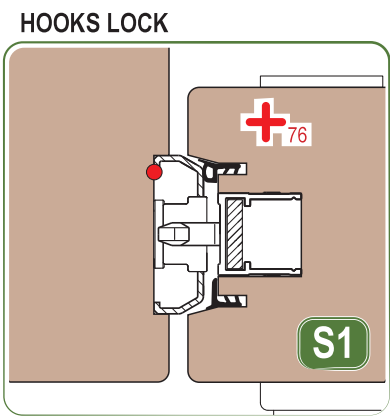
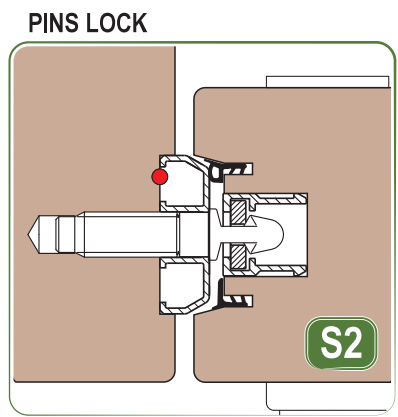
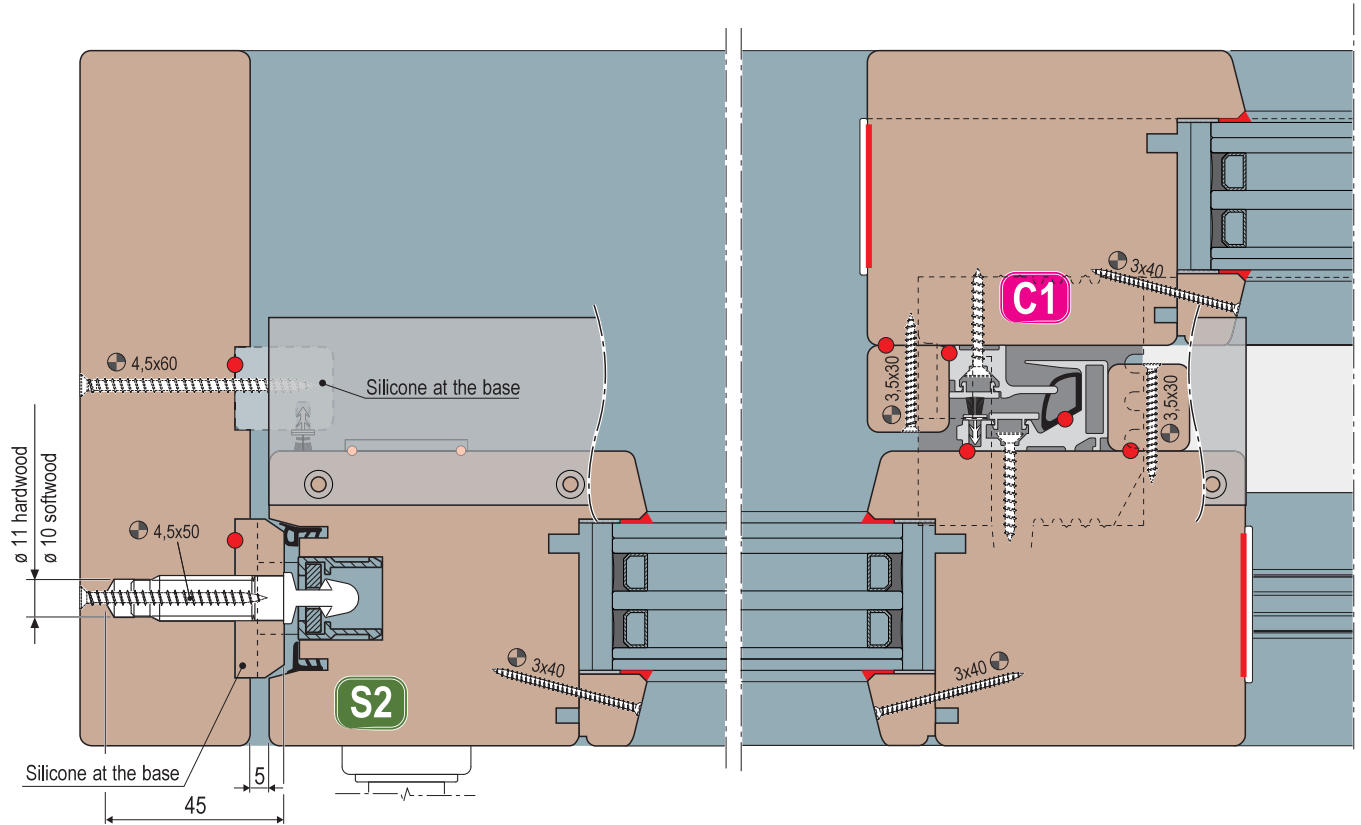

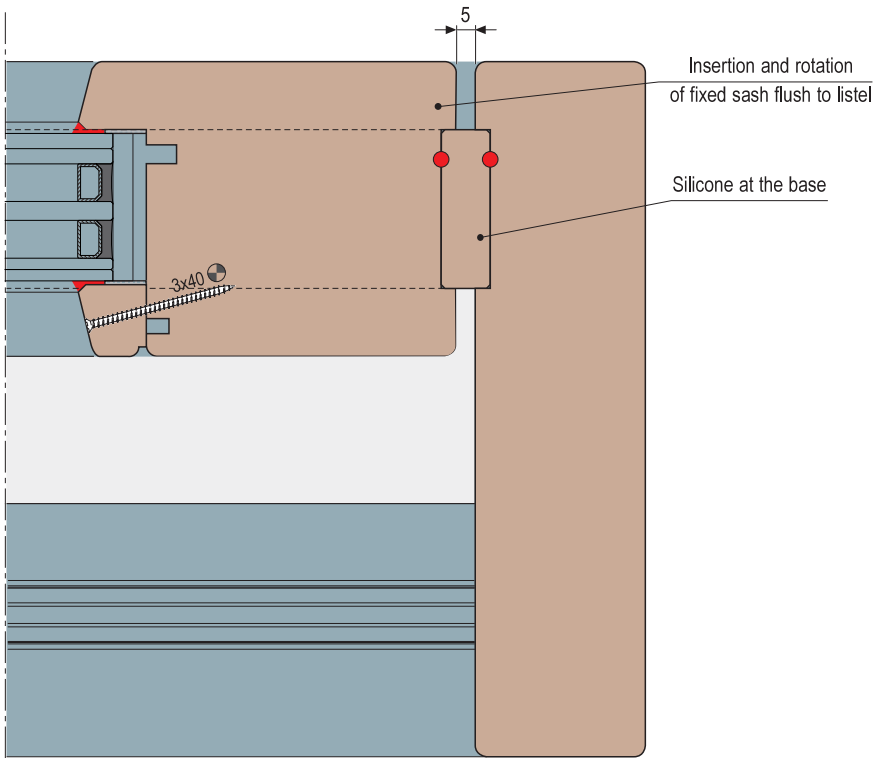

Uni-V

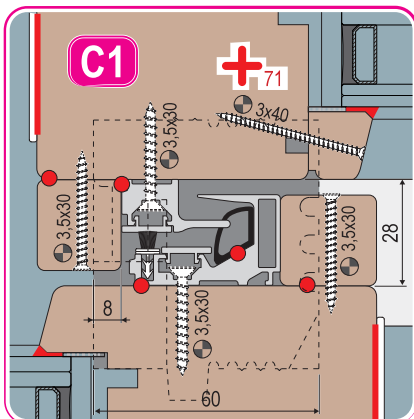

Align the pad to the sash jamb

Base

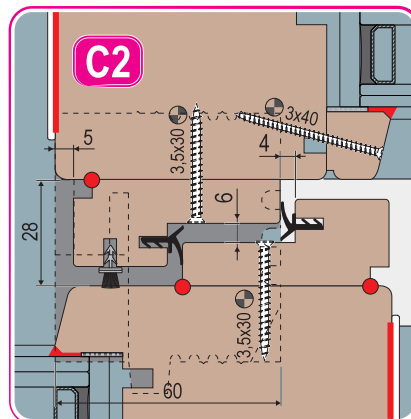

Align the pad to the sash jamb

Easy

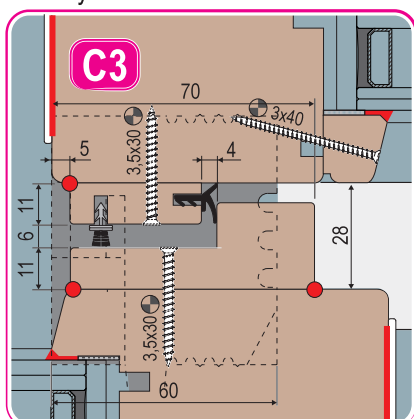

Align the pad to the sash jamb

Uni-V Mini

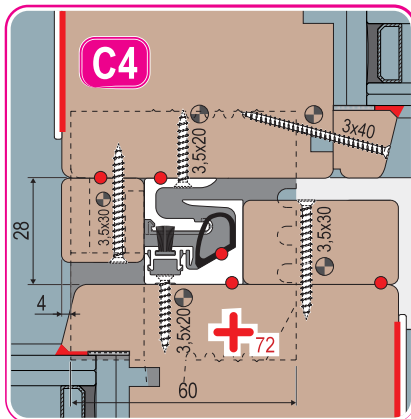

Align the pad to the sash jamb

Calculation of jambs and listels measurements



As an example, the picture represents a case with 22X22 upper guide; the use of other guides needs different accessories even if they are assembled in the same way.

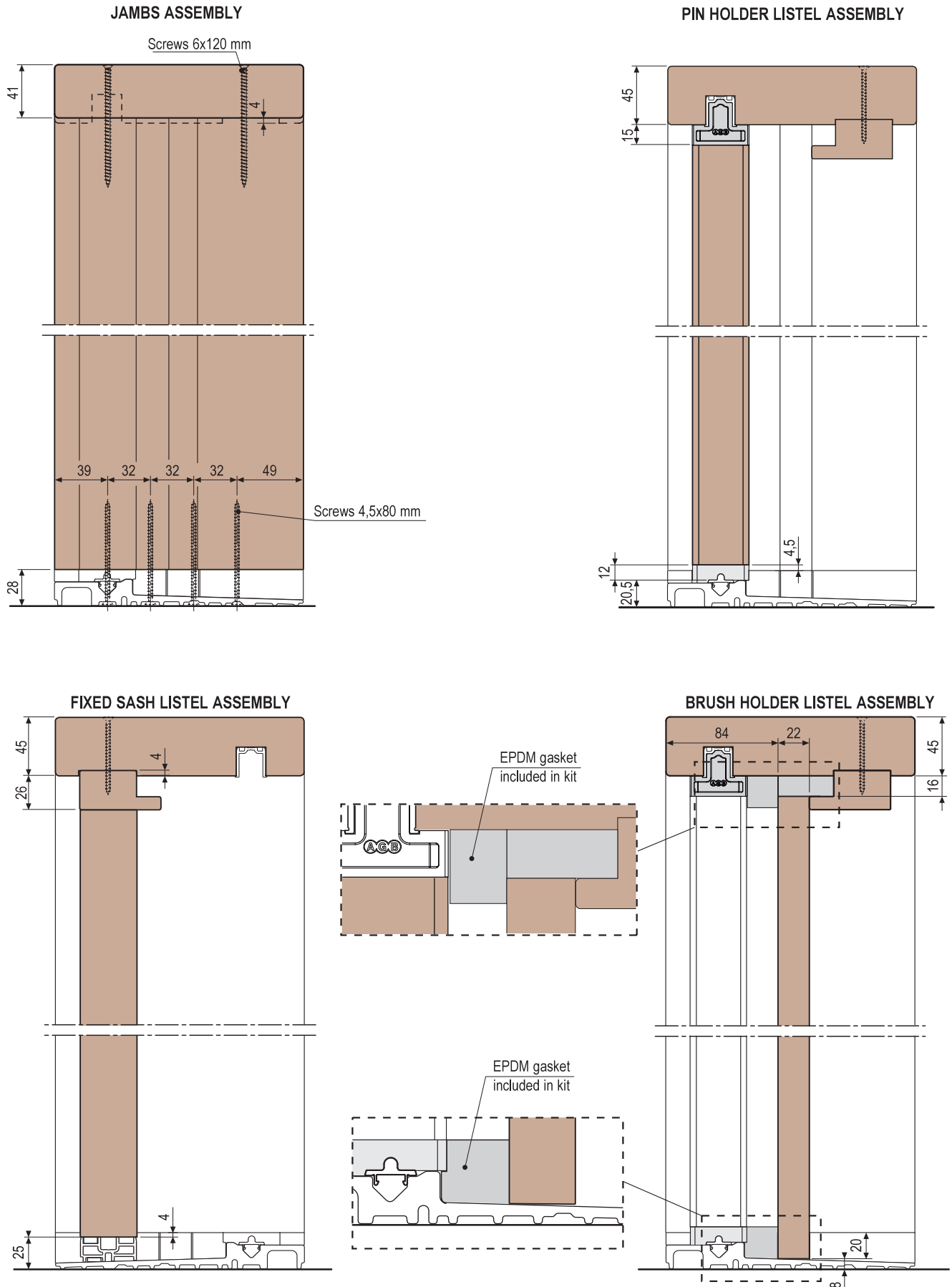

Vertical section A-A - Sliding sash

REDUCED UPPER GUIDE

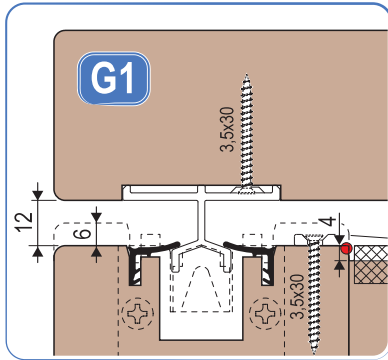

GUIDE 22X13

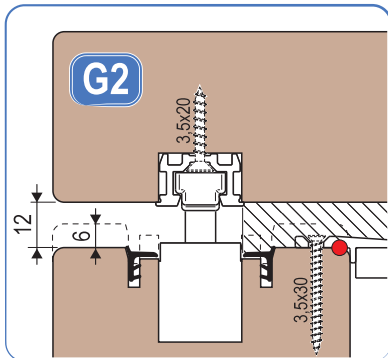

XC S-LINE CARRIAGES (SEAT 16 mm)

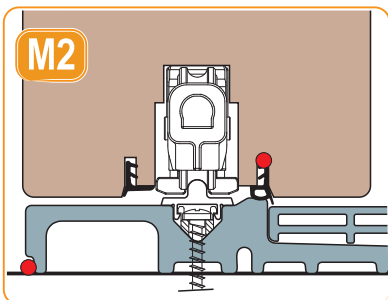

XC S-LINE CARRIAGES (SEAT 18 mm)

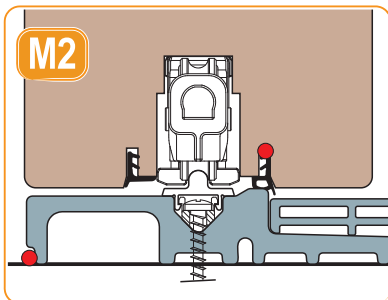

XC S-LINE CARRIAGES (SEAT 22 mm)

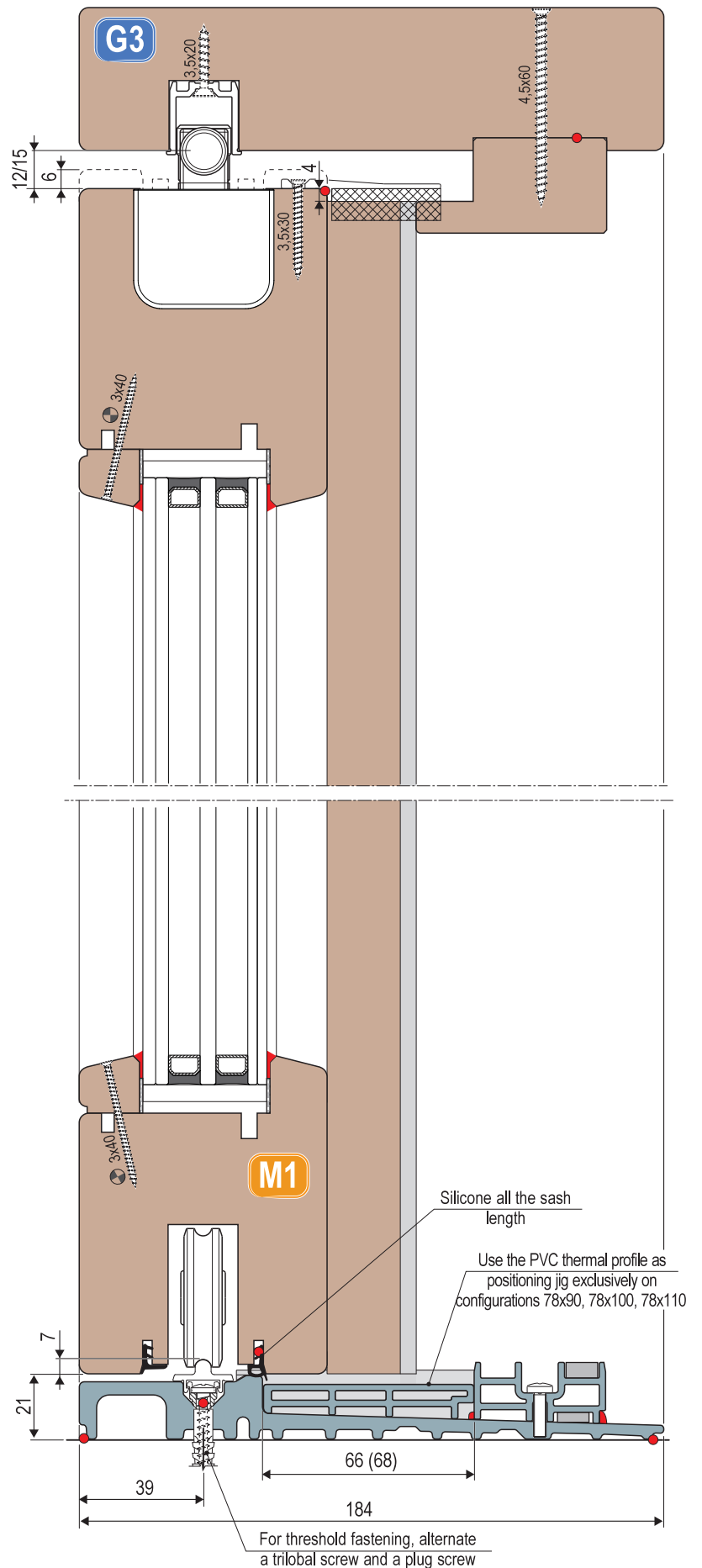
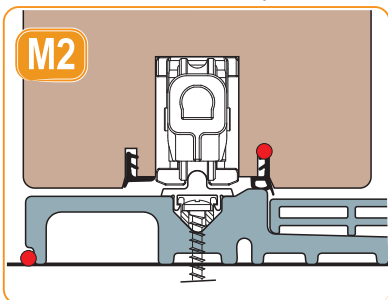

Vertical section B-B - Fixed sash

REDUCED UPPER GUIDE

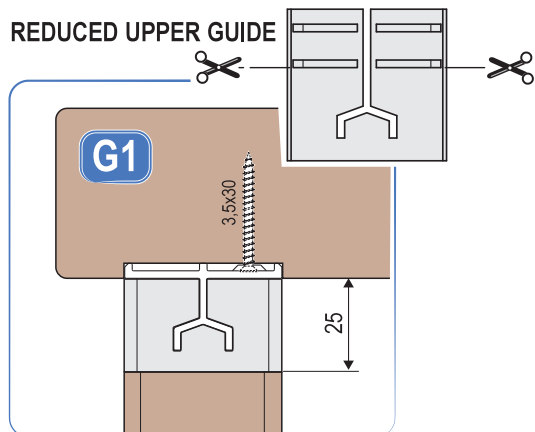

GUIDE 22X13

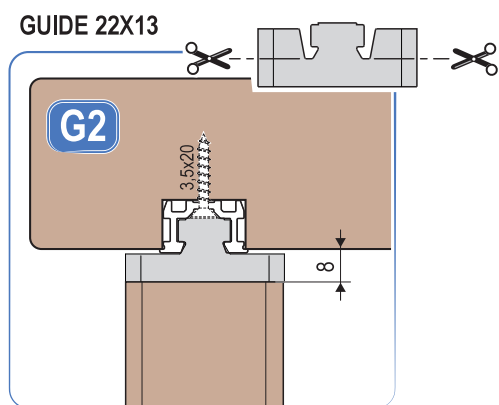

GUIDE 22X22

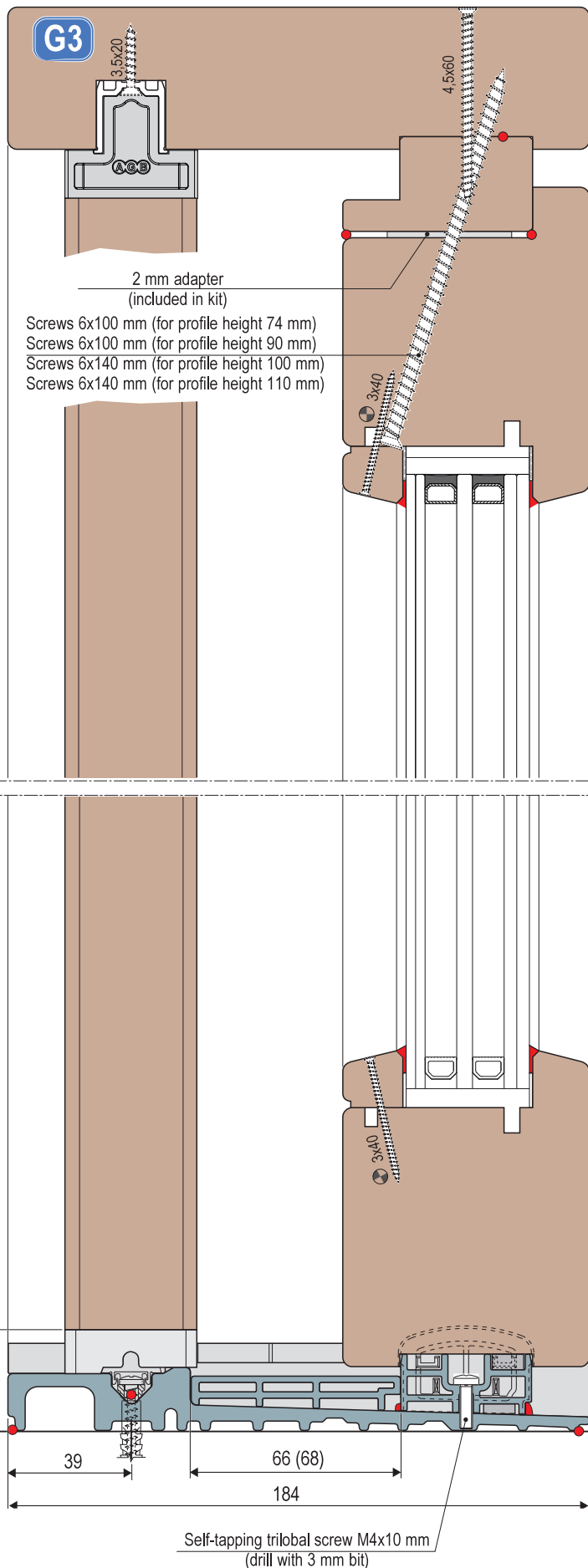
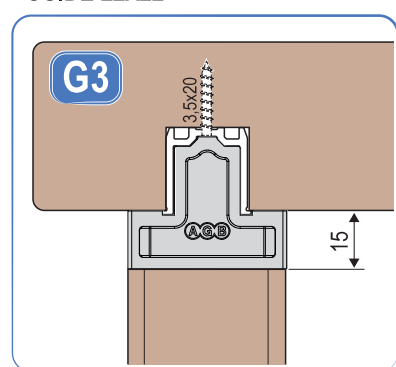

Millings - Vertical section, upper point



It is possible to realise a lower transom height included between 74 and 90 mm; in this case, it is necessary to use XC S-Line carriages with lower transom between 90 and 110 mm. It is possible to use both carriages.

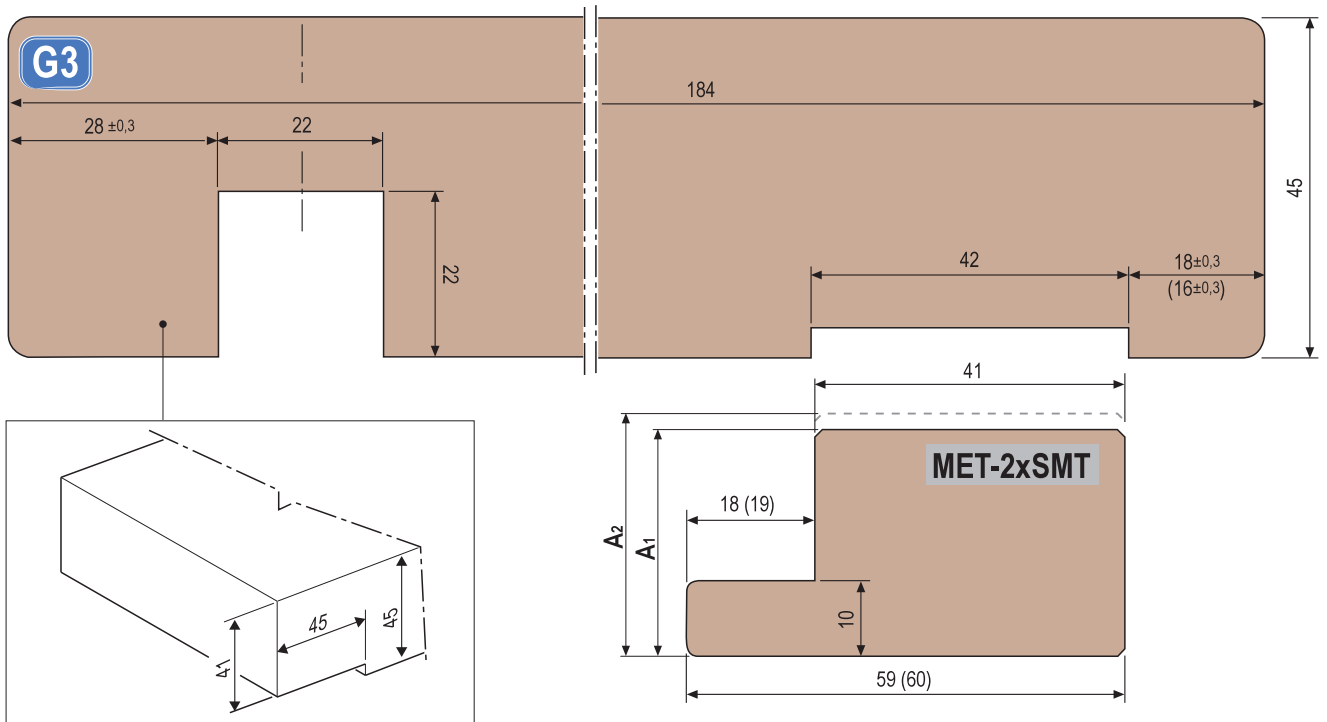

| | G1 | G2 | G3 |
|---------------------|----|----|----|
| A ₁ = 30 | ✓ | ✓ | ✓ |
| A ₂ = 33 | ✗ | ✗ | ✓ |

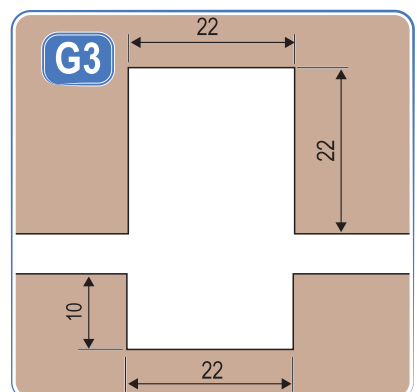
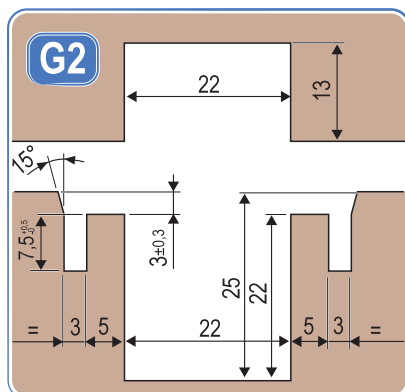
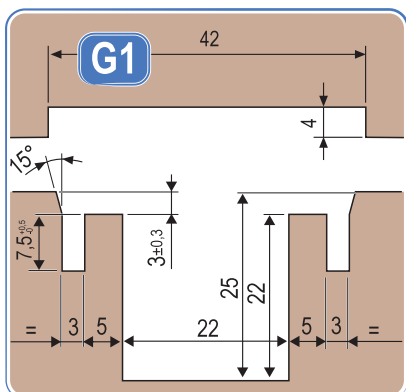
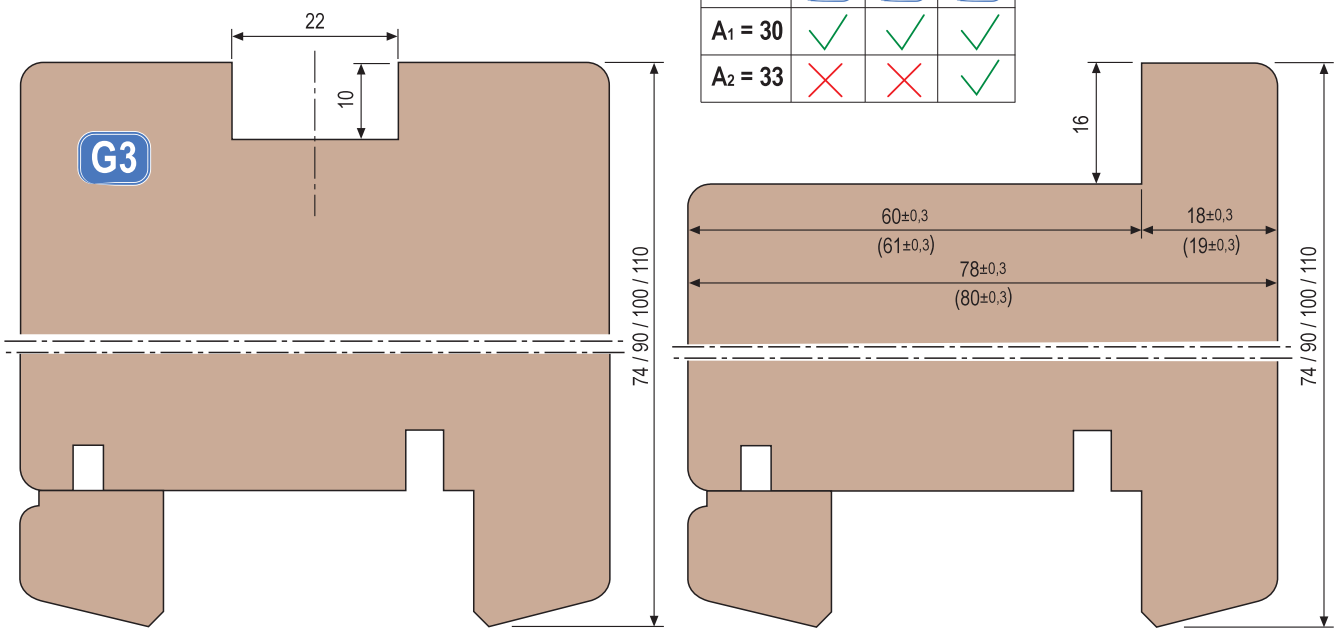

Millings - Vertical section, lower point



It is possible to realise a lower transom height included between 74 and 90 mm; in this case, it is necessary to use XC S-Line carriages with lower transom between 90 and 110 mm. It is possible to use both carriages.

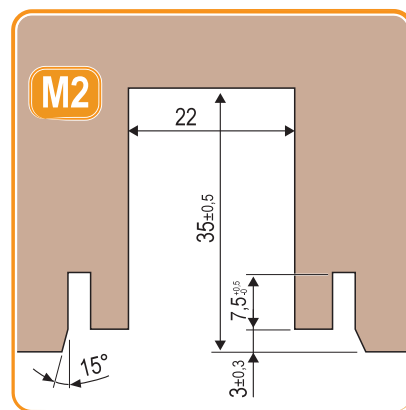
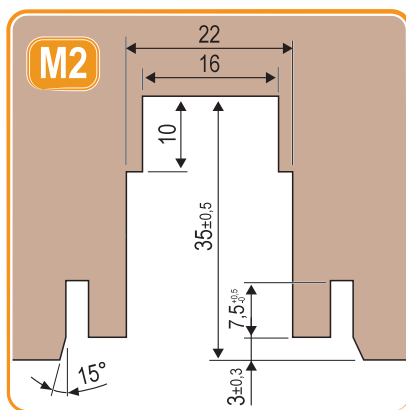
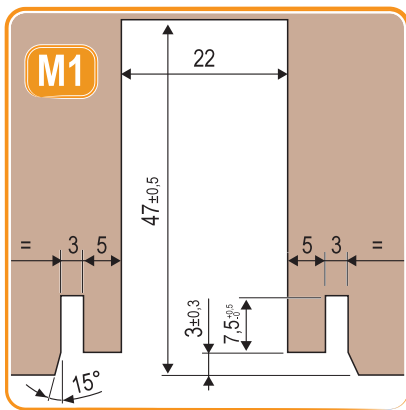
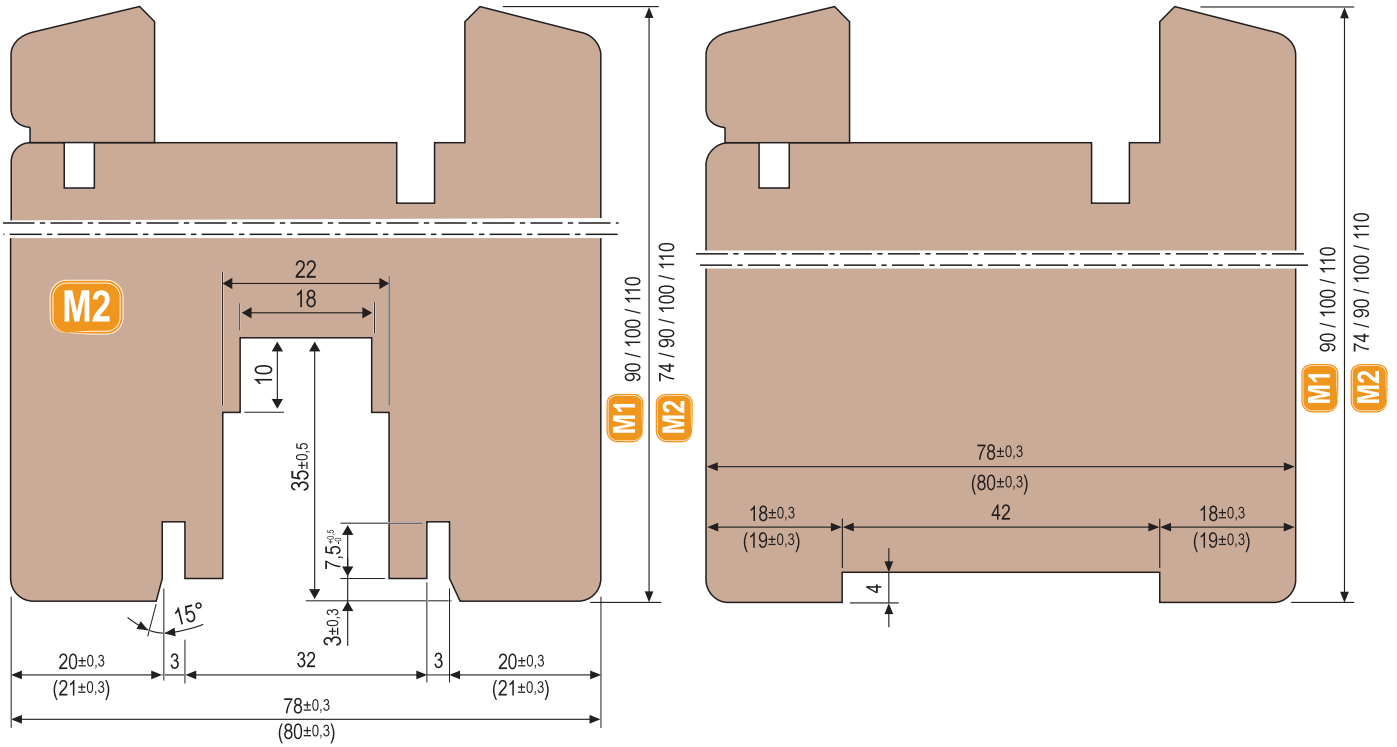

Millings - Horizontal section, sliding sash



It is possible to realise a lower transom height included between 74 and 90 mm; in this case, it is necessary to use XC S-Line carriages with lower transom between 90 and 110 mm. It is possible to use both carriages.

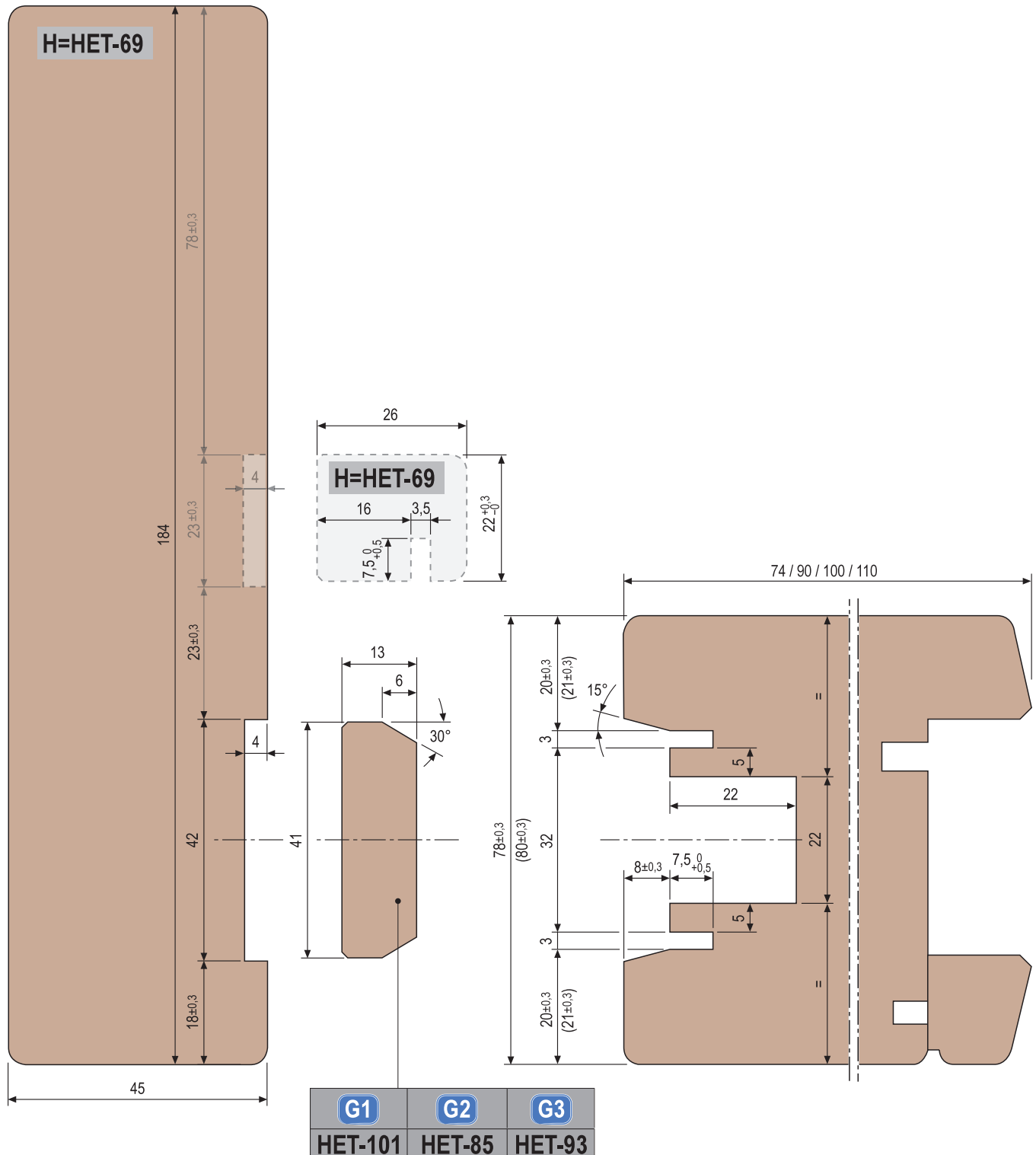

Millings - Horizontal section, fixed sash

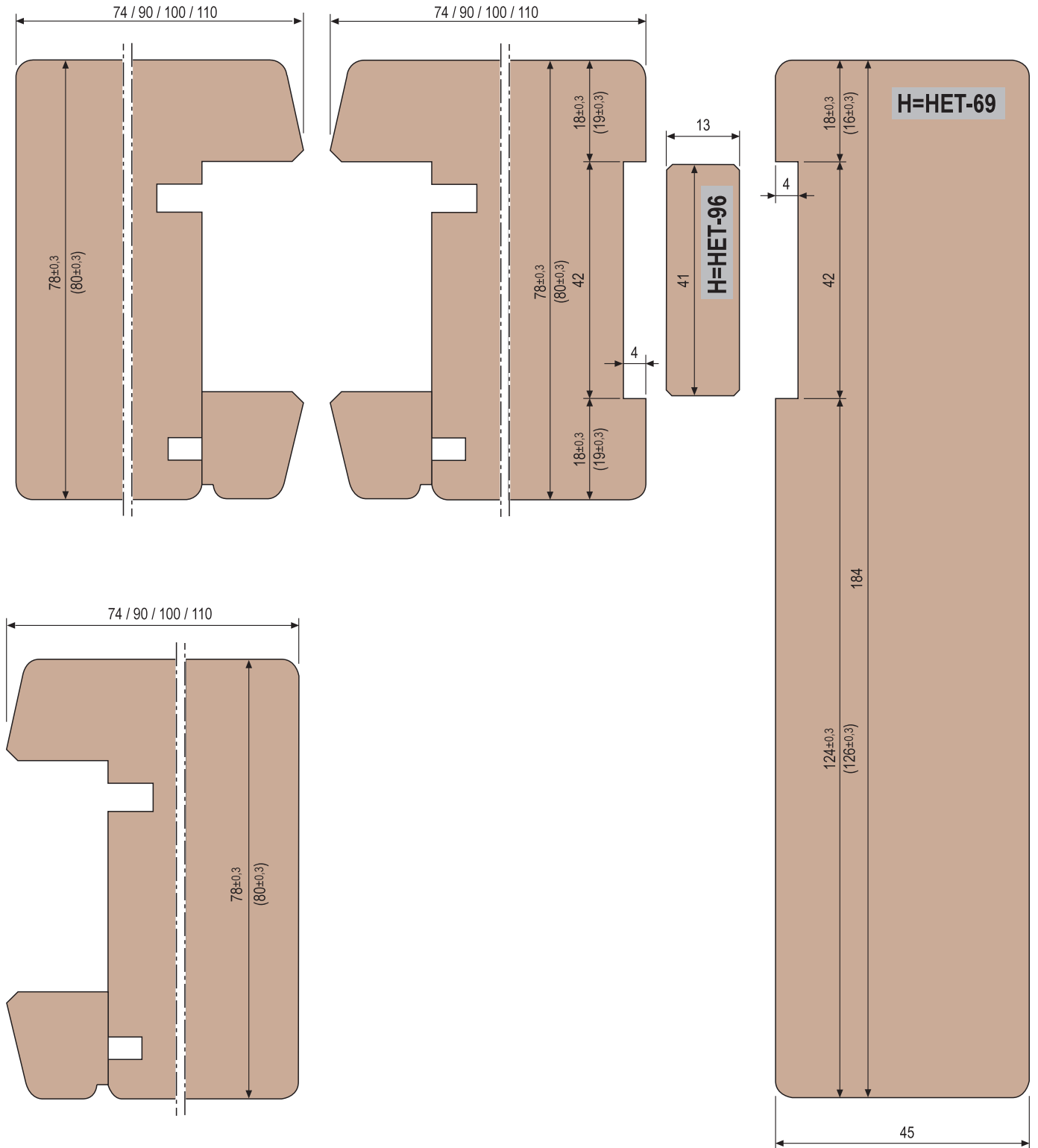

Millings - Horizontal section for central point

Uni-V listels

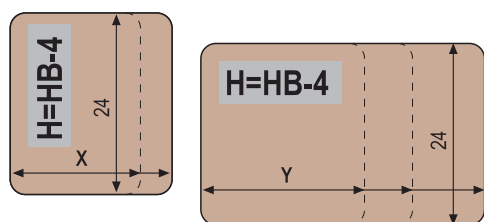

| Sash section width | | | |
|--------------------|--------|--------|--------|
| 74 | 90 | 100 | 110 |
| X = 16 | X = 22 | X = 22 | X = 22 |
| Y = 16 | Y = 26 | Y = 36 | Y = 46 |
| Z = 24 | Z = 40 | Z = 50 | Z = 60 |

Uni-V Mini listel

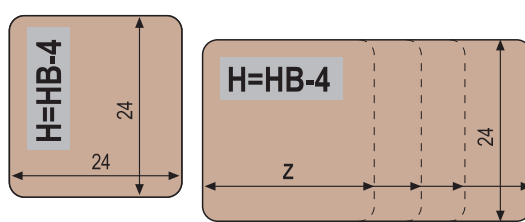

Easy listels

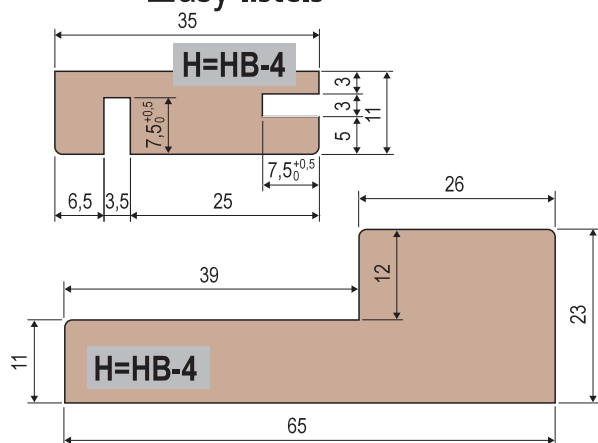

Basic listels

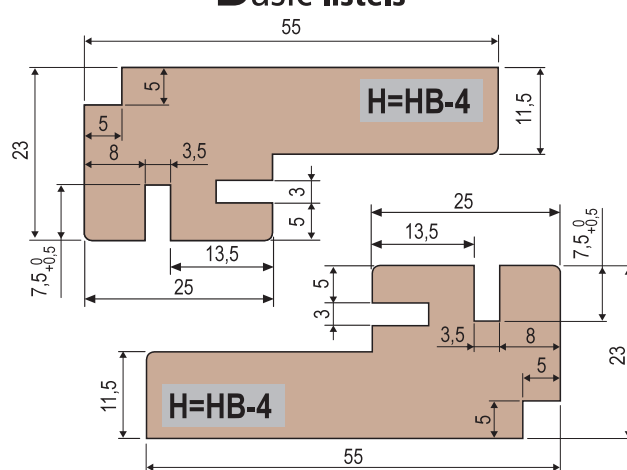

Millings - Central point horizontal section, coaxial sashes



It is possible to realise a lower transom height included between 74 and 90 mm; in this case, it is necessary to use XC S-Line carriages with lower transom between 90 and 110 mm. It is possible to use both carriages.

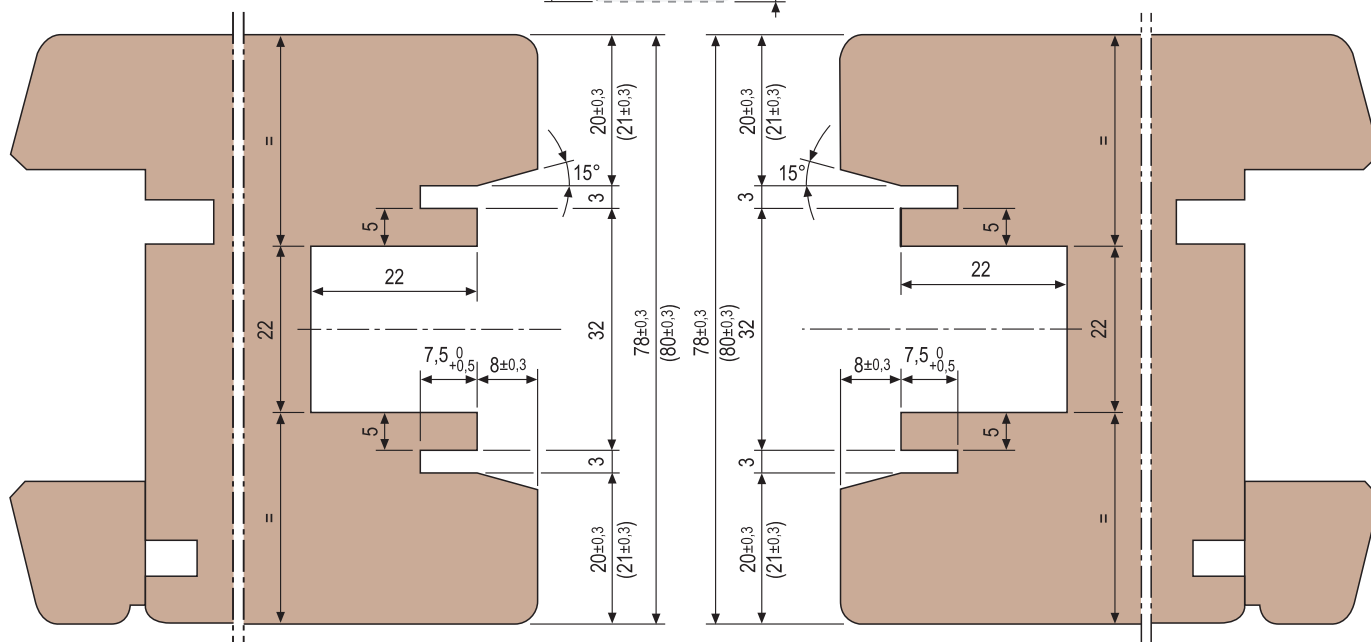
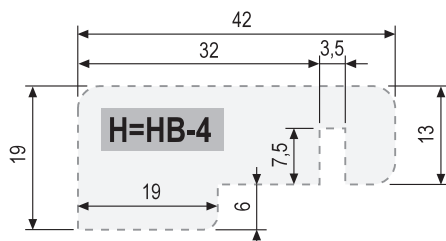

Formulas of accessories cut

| | | LAYOUT A | | | LAYOUT E | | |
|--|-------------------------------|--------------------|-------------|-------------|-----------------------|-------------|-------------|
| | | | | | | | |
| | XC XC S-Line | HB-94 | HB-94 | HB-99 | HB-94 | HB-94 | HB-99 |
| | | | MET-2xSMT-2 | - | | MET-2xSMT-2 | - |
| | | | - | MET-2xSMT-2 | | - | MET-2xSMT-2 |
| | | MET-2xSMT-2 | - | - | MET-2xSMT-2 | - | - |
| | | HET-101 | HET-93 | HET-85 | HET-101 | HET-93 | HET-85 |
| | | HB-65 | HB-18 | HB-18 | HB-65 | HB-18 | HB-18 |
| | | LB | | | (2 pieces) LB LB+4 | | |
| | XC XC S-Line | | | | | | |
| | XC XC S-Line | | | | | | |
| | XC XC S-Line | (2 pieces) 80 mm + | | | | | |

| | |
|--|-------------|
| | MET |
| | MET-2xSMT-2 |
| | HB-14 |
| | HB-4 |
| | HB-14 |

| | | LAYOUT A | | | |
|--|------------------------|----------------------|----------------------|----------------------|----------------------|
| | | Uni-V | Uni-V Mini | Easy | Base |
| | Sash section width 74 | LBF-63 | | | |
| | Sash section width 90 | | LBF-59 | LBF-55 | LBF-55 |
| | Sash section width 100 | LBF-69 | | | |
| | Sash section width 110 | | | | |
| | | LAYOUT E | | | |
| | | Uni-V | Uni-V Mini | Easy | Base |
| | Sash section width 74 | (2 pieces) LBF-63 | | | |
| | Sash section width 90 | | (2 pieces) LBF-59 | (2 pieces) LBF-55 | (2 pieces) LBF-55 |
| | Sash section width 100 | (2 pieces) LBF-69 | | | |
| | Sash section width 110 | | | | |

LAYOUTS B & F

- Sash with one transom in the lower part with possible base.
- Vertical - lower external gasket: balloon with EPDM vulcanised edge.
- PVC upper gasket with wing.
- EPDM sponge extruded central point gasket.
- Upper locking profile in aluminium with tightness waterproof sponge.
- Tests about water, air, wind and impact realized with glass: 44.1/10/5/10/33.1 (minimum possible).
- High upper guide.
- Distance between the sashes 28 mm.
- Layout F with symmetric central point and aluminium pin holder profile and extremity caps for the locking system.

Calculation of sliding sashes dimensions

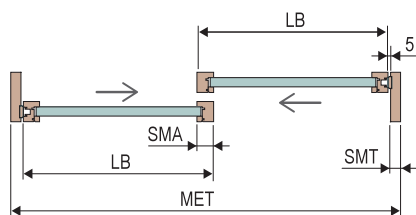
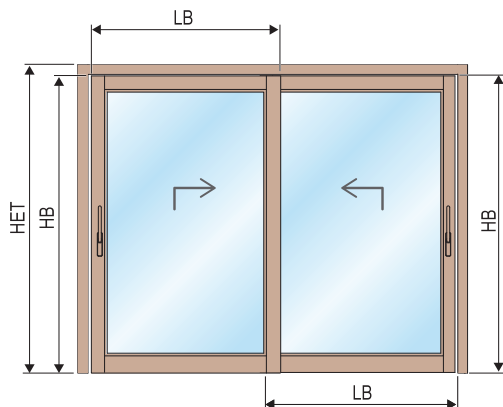

Layout B
2 sliding sashes
 $LB = [MET - 2 \times (SMT + 5)] : 2 + SMA : 2$

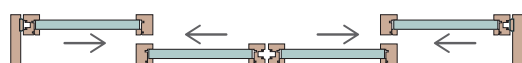

Layout F
4 sliding sashes
 $LB = [MET - 15 (2 \times SMT)] : 4 + SMA : 2$

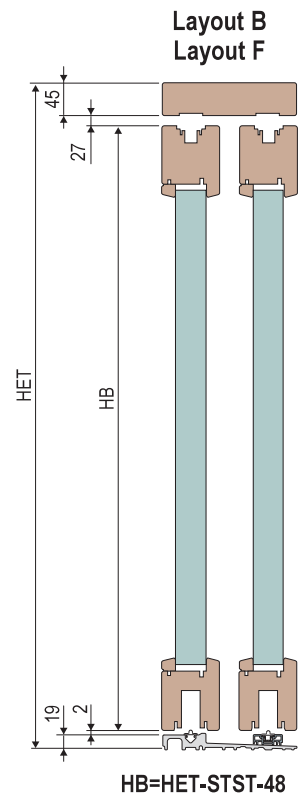

The indications in this section refer to lift&slide installations with top guide. However, the layout B of lift&slide assembly can be constructed with reduced top guide. In this case, please refer to specifications in the section dedicated to layouts A-E.



This section of the manual includes only working processes and indications which distinguish B-F layouts from A-E layouts. If you can't find some details, please refer to the section dedicated to A-E layouts.

Hardware diagram with hooks lock**1 Hooks lock**

G039EE.03.XX HB=1775-2150 Handle h = 1000
 G039EE.04.XX HB=1925-2400 Handle h = 1000
 G039EE.05.XX HB=2325-2750 Handle h = 1000

2 Additional hook kit - G05008.00.00**3 Microventil. additional hook kit - G05010.00.00****4 Hooks lock for second sash**

GR39EE.03.01 HB=1775-2150 Handle h = 1000
 GR39EE.04.01 HB=1925-2400 Handle h = 1000
 GR39EE.05.01 HB=2325-2750 Handle h = 1000

5 Hooks extension 500 mm - G04600.01.01**6 Covering profile 1000 mm - G04401.02.01****7 Gas spring kit - GMG702.04.00****8 XC basic carriages kit- G04104.00.00****9 XC suppl. carriages kit - G04108.00.00****10 XC S-Line carriages kit - G04109.00.00****11 XC S-Line suppl. carriages kit - G04110.00.00****12 Carriages connecting rod**

G04601.00.01 L=1000 G04601.00.03 L=1800
 G04601.00.02 L=1400 G04601.00.04 L=2700

13 Handle fastebning plate

G05371.M5.00 hole M5
 G05371.M6.00 hole M6

14 Anti-burglar plate kit - G05004.00.00**15 Sensors**

G05006.00.86 Grey
 G05006.00.93 Black
 G05003.00.00 Clip

16 Lateral lock. prof. for hooks lock

G01359.03.XX GR3 predisposition 2 hooks
 G01359.04.XX GR4 predisposition 2 hooks
 G01359.05.XX GR5 predisposition 2 hooks
 G01359.13.XX GR3 predisposition 3 hooks
 G01359.14.XX GR4 predisposition 3 hooks
 G01359.15.XX GR5 predisposition 3 hooks
 G01359.23.XX GR3 predisp. signal system
 G01359.24.XX GR4 predisp. signal system
 G01359.25.XX GR5 predisp. signal system

17 Extens. for lock. prof. for hooks lock

G01360.01.XX L=500

18 Coax. sashes lock. prof. for hooks lock + caps

G01373.13.XX L=2075 HB=1775-2150 with hooks strik.
 G01373.14.XX L=2325 HB=1925-2400 with hooks strik.
 G01373.15.XX L=2750 HB=2325-2750 with hooks strik.

19 Coax. sashes lock. prof. extens. for hooks, 500 mm

G01364.01.XX with hook strik.

20 Striker for lock hook - G06201.00.XX**21 Strik. for lock hook with signal syst. - G06203.00.XX****22 Comp. cap for frame jamb (A)****23 Support for cap (A)****24 Central pad (A)****25 Pad for carriages milling (A)****26 climatech fastening kit (A)****27 Rail fastening kit for sec. sash (A)****28 Rail connect. cap for sec. sash (A)****29 Shaped cap for low. rail (B)****30 Rear lower covering cap (B)****31 Shaped cap for upper guide (B)****32 Terminal cap for lock (B)****33 Rear upper covering cap (B)****34 High upper guide**

G00734.01.XX L=3000
 G00734.02.XX L=4000
 G00734.03.XX L=6000

35 Door stop

G00204.00.91 white
 G00204.00.86 grey
 G00204.00.93 black

36 Thermal pad with brushes - G00728.12.15**37 Upper thermal pad**

G01413.27.96 96 mm G01413.27.0B 120 mm

38 Uni-V central point kit

G02208.25.KK L=2500
 G02208.31.KK L=3100
 G02208.40.KK L=4000

39 Uni-V central point caps kit - G01610.MM.93**40 Uni-V Mini central point kit**

G02211.25.KK L=2500 G02211.40.KK L=4000
 G02211.31.KK L=3100

41 Uni-V Mini central point caps kit

G01623.DX.93 Destro
 G01623.SX.93 Sinistro

42 Climatech threshold kit

G02278.01.ZZ L=3000 G02278.04.ZZ L=6000
 G02278.02.ZZ L=4000 G02278.14.86 L=7000
 G02278.03.ZZ L=5000

43 Climatech thres. adapter for per high rail

G01212.01.01 L=3000 G01212.04.01 L=6000
 G01212.02.01 L=4000 G01212.14.01 L=7000
 G01212.03.01 L=5000

44 Gasket for high thres. - 7 meters - G02210.01.00**45 Second sliding sash rail**

G02217.11.86 L=1500 G02217.03.86 L=2500
 G02217.12.86 L=2000 G02217.14.86 L=3000

46 Thermal profile

G01311.02.86 L=2000
 G01311.04.86 L=3000

47 PVC upper flexible gasket

G00733.02.01 L=40
 G00733.02.02 L=200

48 Gaskets kit for sliding sash

G02000.12.JJ L1500xH2500
 G02000.13.JJ L3000xH3000
 G02000.15.JJ L4000xH4000

49 Flexible gasket for Easy point

G00733.04.01 L=40
 G00733.04.02 L=200

50 Brush gasket

G02002.16.00 L=1600
 G02002.25.00 L=2500
 G02002.31.00 L=3100

51 XC anti-derailed adapter- G01611.02.00**52 Rod guide - G05102.00.00****53 S-Line anti-derailed adapter - G01611.01.00****54 S-Line rod guide - G00728.00.29****55 Handle access. kit for 78 and 92 thick.**

G05390.00.00 screws M5
 G05390.01.00 screws M6

56 Handle**(A) Caps and accessories kit**

G0021B.MM.JJ
 G0021F.MM.JJ

(B) Universal guide caps kit - G00203.02.JJ

XX = 01 Alum. silver
 02 Alum. electrocolour

KK = 01 silver
 93 black

EE = 27 backset 27,5
 37 backset 37,5

MM = DX right hand
 SX left hand

ZZ = 86 grey RAL 7035
 94 brown RAL 8019

JJ = 86 grey RAL 7035
 93 black

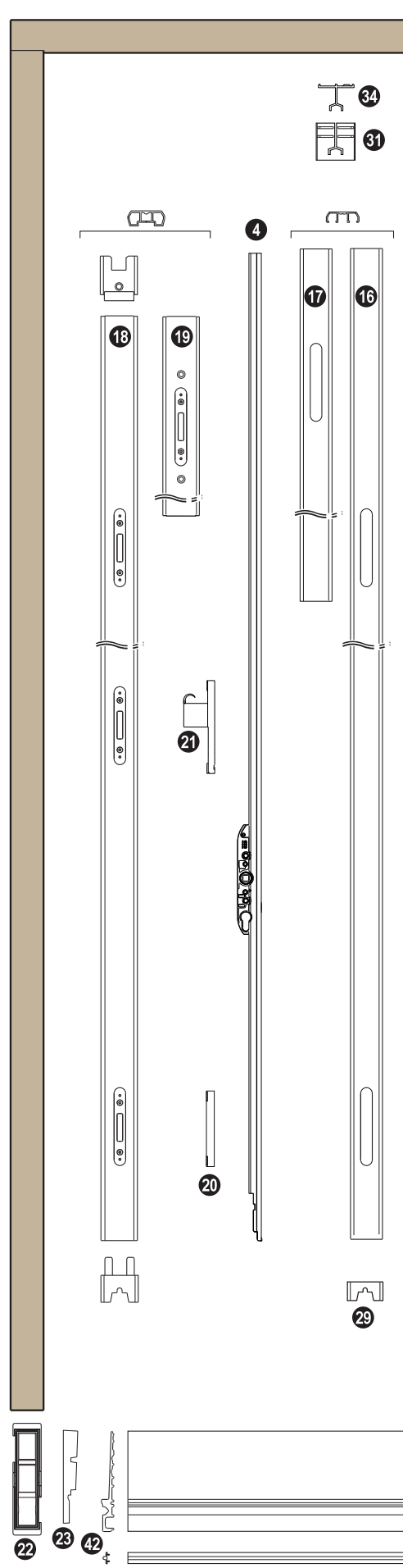

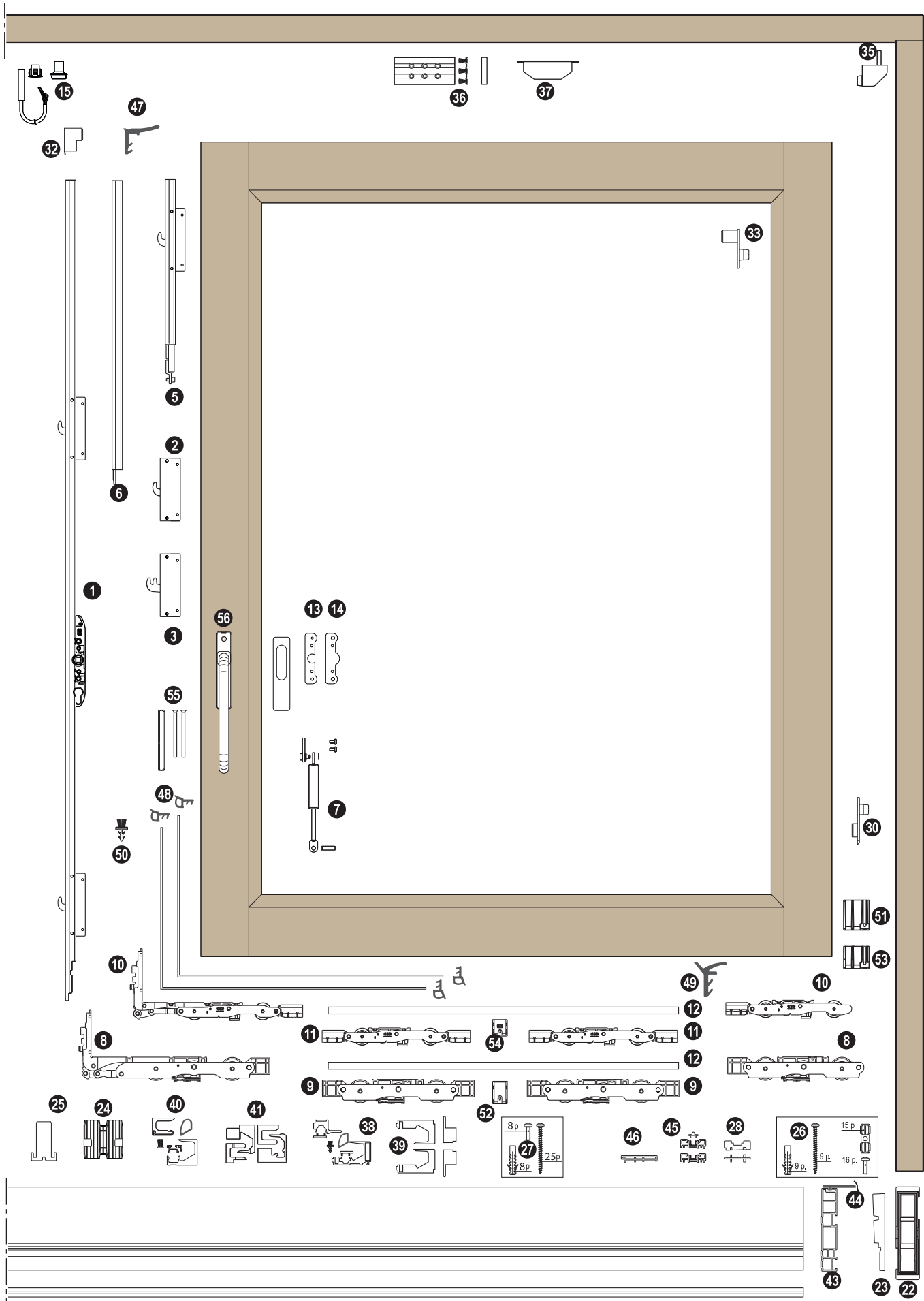

Hardware diagram with pins lock

- 1 Pins lock**
G040EE.01.XX Handle h = 400 HB=800-1200
G040EE.02.XX Handle h = 400 HB=1170-1800
G040EE.03.XX Handle h = 1000 HB=1770-2150
G040EE.04.XX Handle h = 1000 HB=1920-2400
G040EE.05.XX Handle h = 1000 HB=2401-2750
- 2 Pins extension 500 mm** - G04401.01.01
- 3 Covering profile 1000 mm** - G04401.02.01
- 4 Gas spring kit** - GMG702.04.00
- 5 XC basic carriages kit** - G04104.00.00
- 6 XC suppl. carriages kit** - G04108.00.00
- 7 XC S-Line carriages kit** - G04109.00.00
- 8 XC S-Line suppl. carriages kit** - G04110.00.00
- 9 Carriages connecting rod**
G04601.00.01 L=1000 G04601.00.03 L=1800
G04601.00.02 L=1400 G04601.00.04 L=2700
- 10 Handle fastening plate**
G05371.M5.00 hole M5
G05371.M6.00 hole M6
- 11 Anti-burglar plate kit** - G05004.00.00
- 12 Sensors**
G05006.00.86 grey
G05006.00.93 black
G05003.00.00 Clip
- 13 Pin holder profile for lateral point**
G01341.00.XX L=1800 HB=800-1800
G01341.01.XX L=2900 HB=1770-2900
G01341.02.XX L=2900 HB=2401-2900
- 14 Locking profile for coaxial sashes + caps**
G01361.01.XX L=1125 HB=810-1200
G01361.02.XX L=1725 HB=1175-1800
G01361.03.XX L=2075 HB=1775-2150 with caps
G01361.04.XX L=2325 HB=1925-2400
G01361.05.XX L=2750 HB=2325-2750

G01340.01.XX L=1125 HB=810-1200
G01340.02.XX L=1725 HB=1175-1800 with caps and
G01340.03.XX L=2075 HB=1775-2150 ventil. pin
G01340.04.XX L=2325 HB=1925-2400
G01340.05.XX L=2750 HB=2325-2750
- 15 Coax. sashes lock. prof. extens. for pins, 500 mm**
G01361.97.XX
- 16 Coax. sashes lock. prof. extens. for pins, 1000 mm**
G01757.00.XX
- 17 Pin**
G40728.00.03 for closing
G04902.01.00 for ventilation
- 18 Comp. cap for frame jamb** (A)
- 19 Support for cap** (A)
- 20 Central pad** (A)
- 21 Pad for carriages milling** (A)
- 22 Climatech fastening kit** (A)
- 23 Rail fastening kit for second sash** (A)
- 24 Rail connecting cap for second sash** (A)
- 25 Shaped cap for low. rail** (B)
- 26 Rear lower covering cap** (B)
- 27 Shaped cap for upper guide** (B)
- 28 Terminal cap for lock** (B)
- 29 Rear upper covering cap** (B)
- 30 High upper guide**
G00734.01.XX L=3000
G00734.02.XX L=4000
G00734.03.XX L=6000
- 31 Door stop**
G00204.00.91 white
G00204.00.86 grey
G00204.00.93 black
- 32 Thermal pad with brushes** - G00728.12.15
- 33 Upper thermal pad**
G01413.27.96 96 mm G01413.27.0B 120 mm
- 34 Uni-V central point kit**
G02208.25.KK L=2500
G02208.31.KK L=3100
G02208.40.KK L=4000
- 35 Uni-V central point caps kit** - G01610.MM.93

- 36 Uni-V Mini central point kit**
G02211.25.KK L=2500 G02211.40.KK L=4000
G02211.31.KK L=3100
- 37 Uni-V Mini central point caps kit**
G01623.DX.93 Destro
G01623.SX.93 Sinistro
- 38 Climatech threshold kit**
G02278.01.ZZ L=3000 G02278.04.ZZ L=6000
G02278.02.ZZ L=4000 G02278.14.86 L=7000
G02278.03.ZZ L=5000
- 39 Climatech threshold adapter for high threshold**
G01212.01.01 L=3000 G01212.04.01 L=6000
G01212.02.01 L=4000 G01212.14.01 L=7000
G01212.03.01 L=5000
- 40 Gasket for high threshold - 7 meters** - G02210.01.00
- 41 Rail for second sliding sash**
G02217.11.86 L=1500 G02217.03.86 L=2500
G02217.12.86 L=2000 G02217.14.86 L=3000
- 42 Thermal profile**
G01311.02.JJ L=2000
G01311.04.JJ L=3000
- 43 PVC upper flexible gasket**
G00733.02.01 L=40
G00733.02.02 L=200
- 44 Gaskets kit for sliding sash**
G02000.12.JJ L1500xH2500
G02000.13.JJ L3000xH3000
G02000.15.JJ L4000xH4000
- 45 Flexible gasket for Easy point**
G00733.04.01 L=40
G00733.04.02 L=200
- 46 Brush gasket**
G02002.16.00 L=1600
G02002.25.00 L=2500
G02002.31.00 L=3100
- 47 XC anti-derailed adapter** - G01611.02.00
- 48 Rod guide** - G05102.00.00
- 49 S-Line anti-derailed adapter** - G01611.01.00
- 50 S-Line rod guide** - G00728.00.29
- 51 Handle accessor. kit for 78 and 92 thick.**
G05390.00.00 Viti M5
G05390.01.00 Viti M6
- 52 Handle**

- (A) Caps and accessories kit
G0021B.MM.JJ for layout B
G0021F.MM.JJ for layout F
- (B) Caps kit for universal upper guide 22x13 - G00203.02.JJ

- XX = 01 Alum. silver KK = 01 silver
 02 Alum. electrocolour 93 black
- EE = 27 backset 27,5 MM = DX right hand
 37 backset 37,5 SX left hand
- ZZ = 86 grey RAL 7035 JJ = 86 grey RAL 7035
 94 brown RAL 8019 93 black

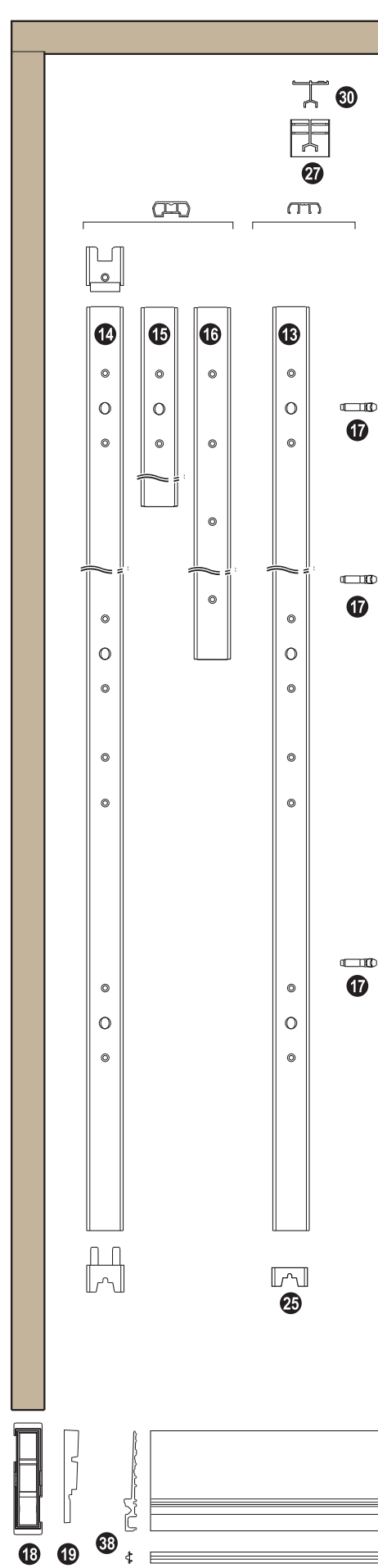

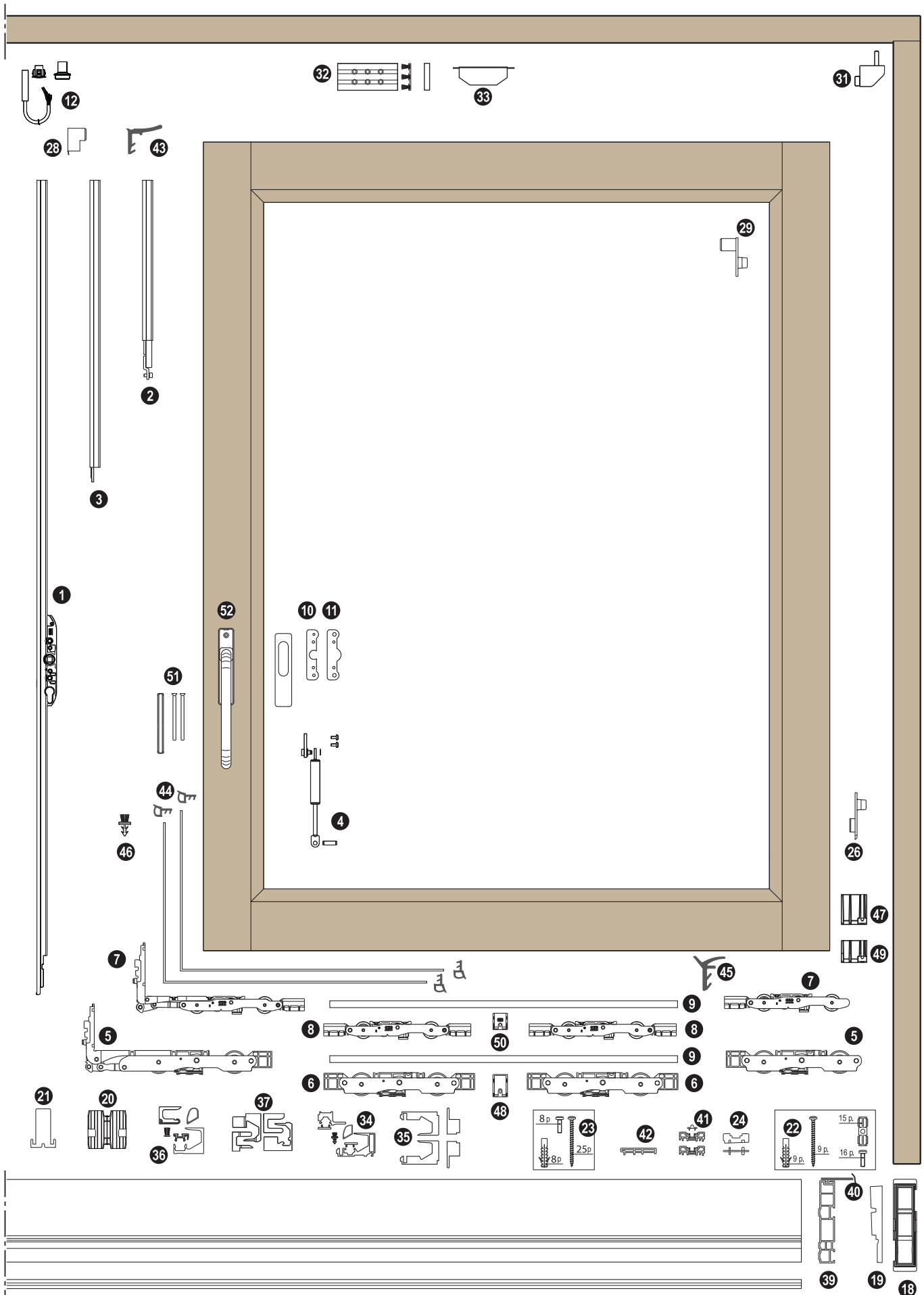

Horizontal section

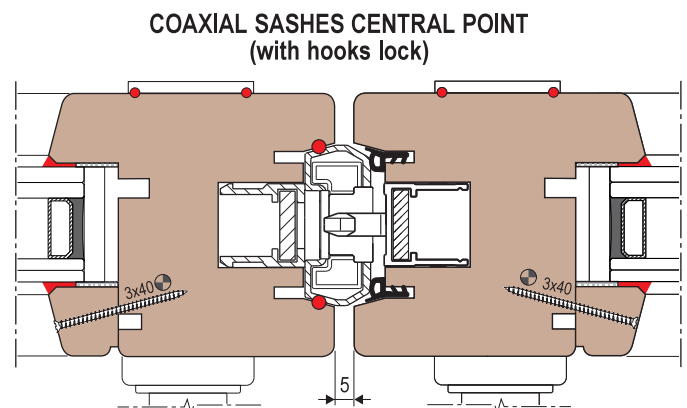
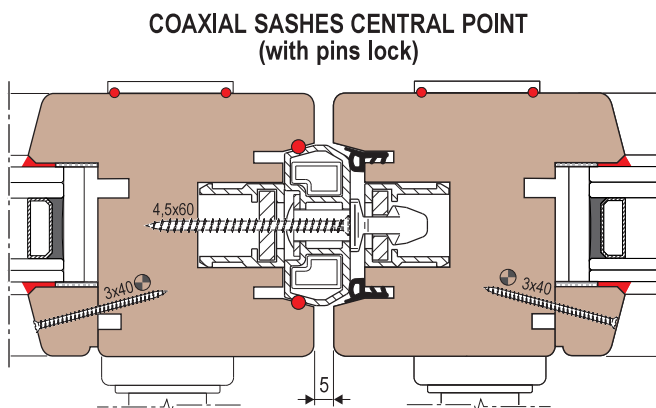
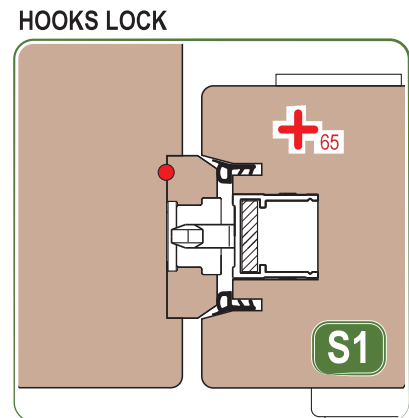
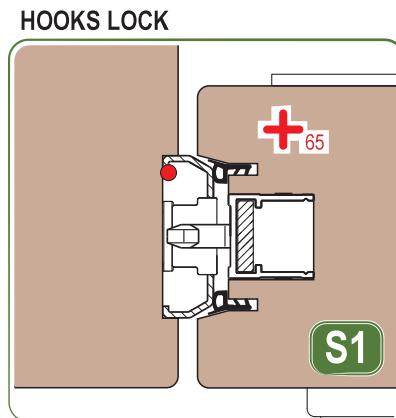
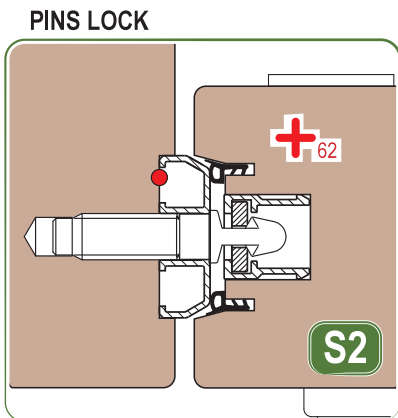
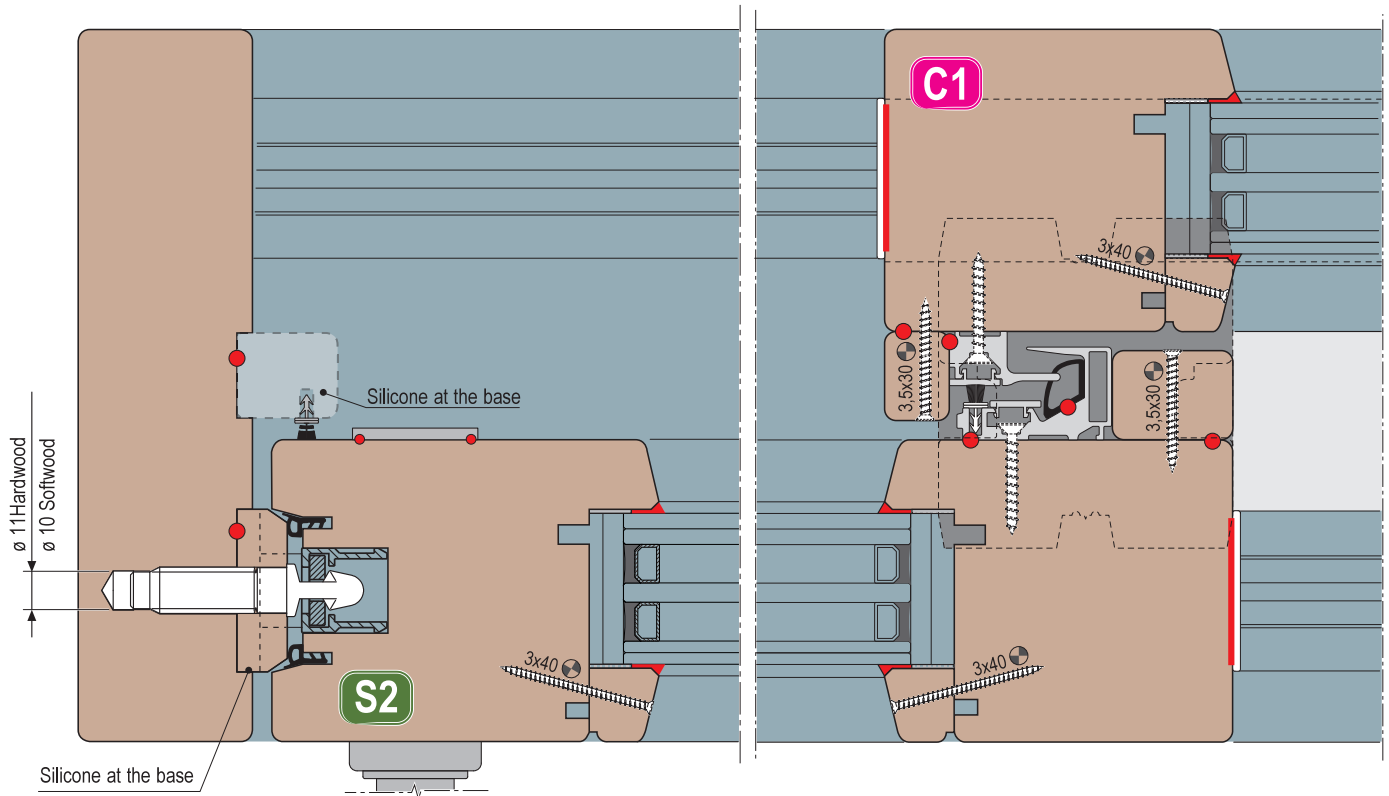

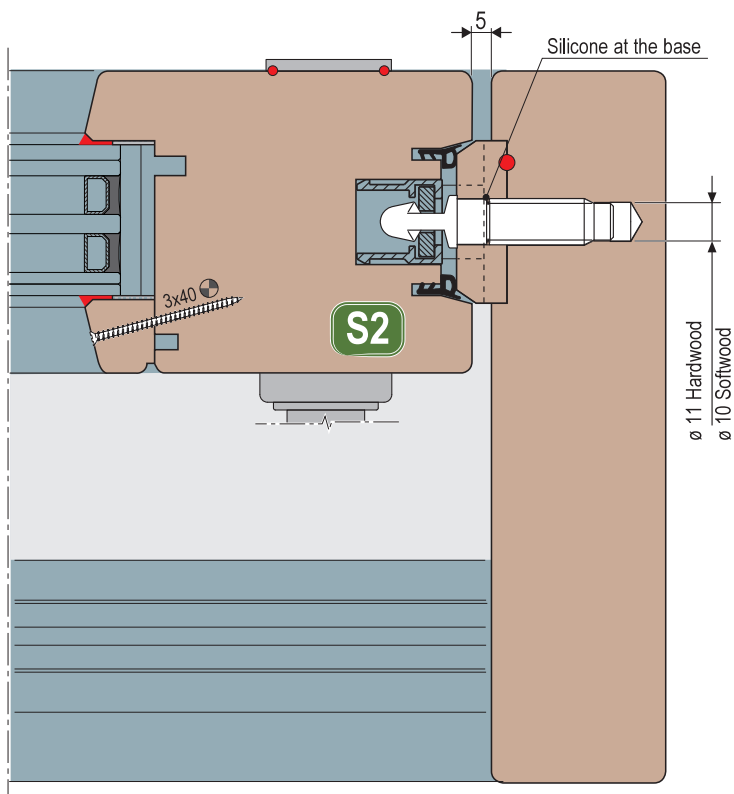

Uni-V

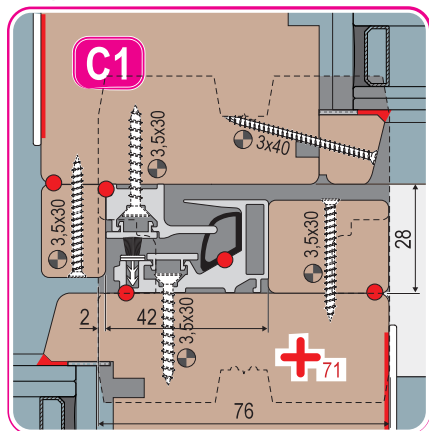

Align the pad to the sash jamb

Base

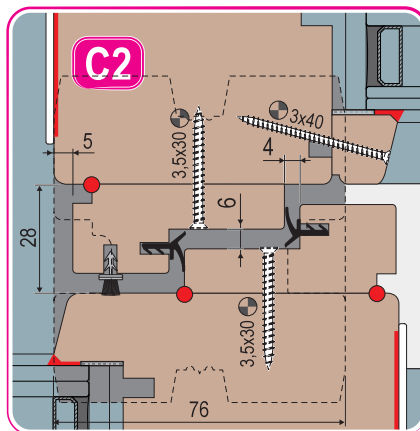

Align the pad to the sash jamb

Easy

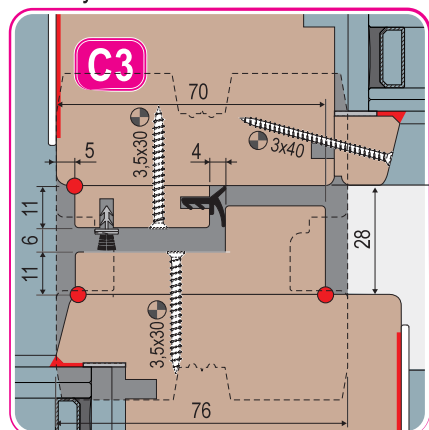

Align the pad to the sash jamb

Uni-V Mini

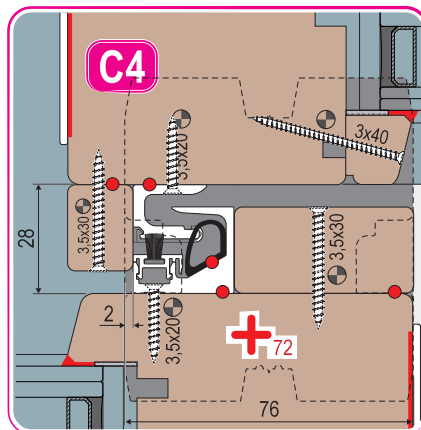

Align the pad to the sash jamb

PAD CUT
(only for sash section width, 74 thickness)

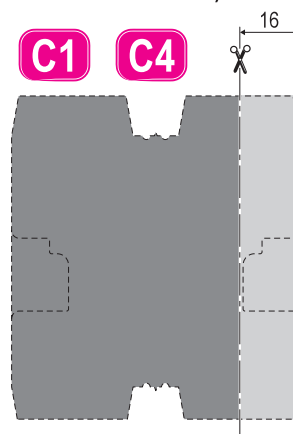

Vertical section

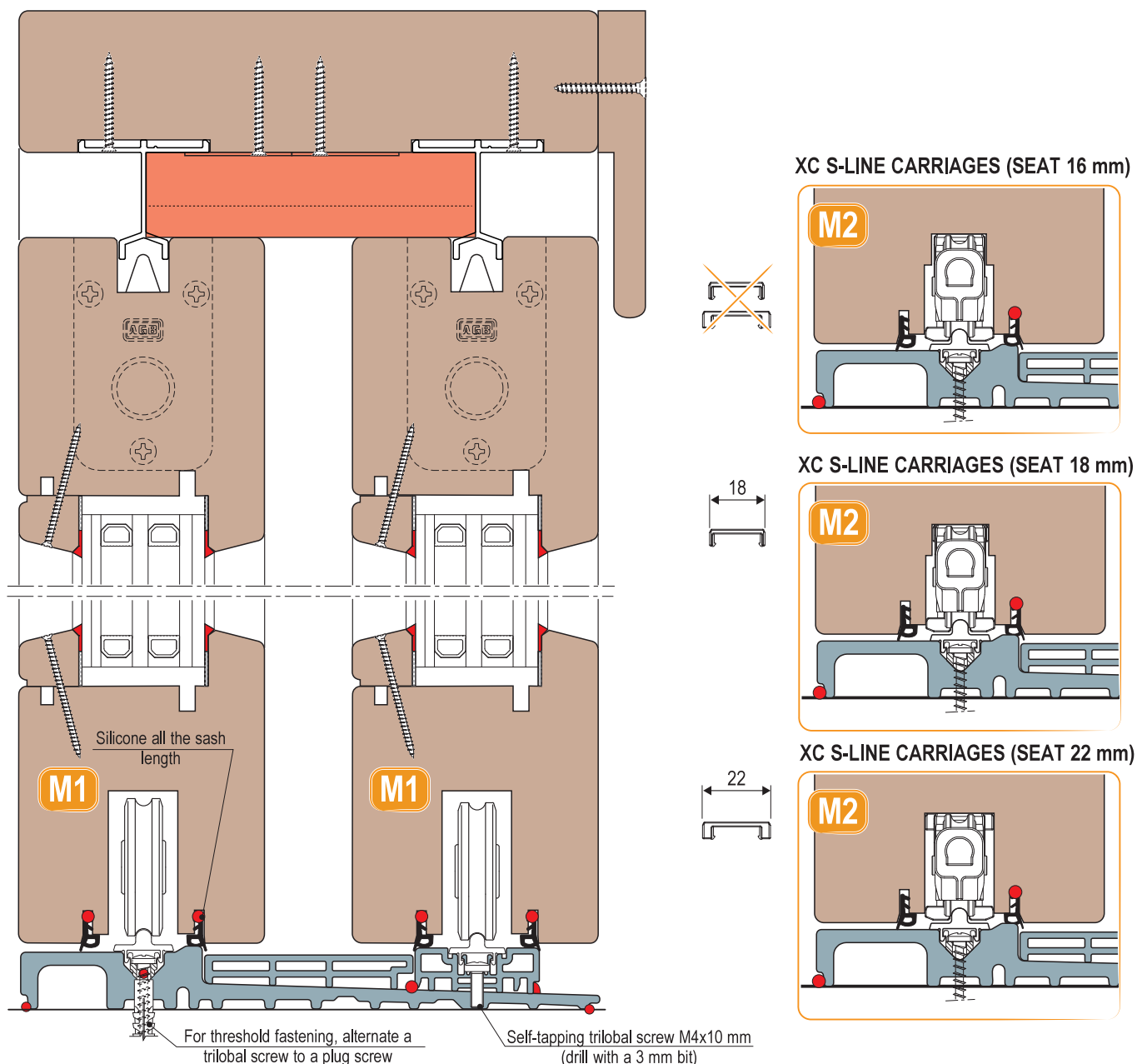

Cut and positioning of upper pad

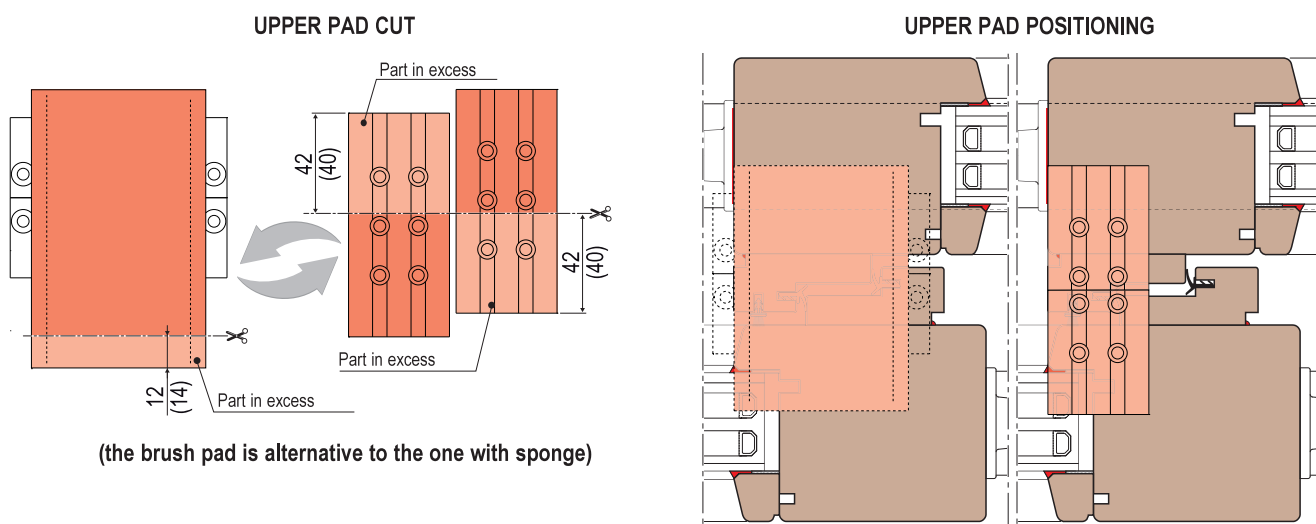

Wood millings: horizontal section of frame jamb

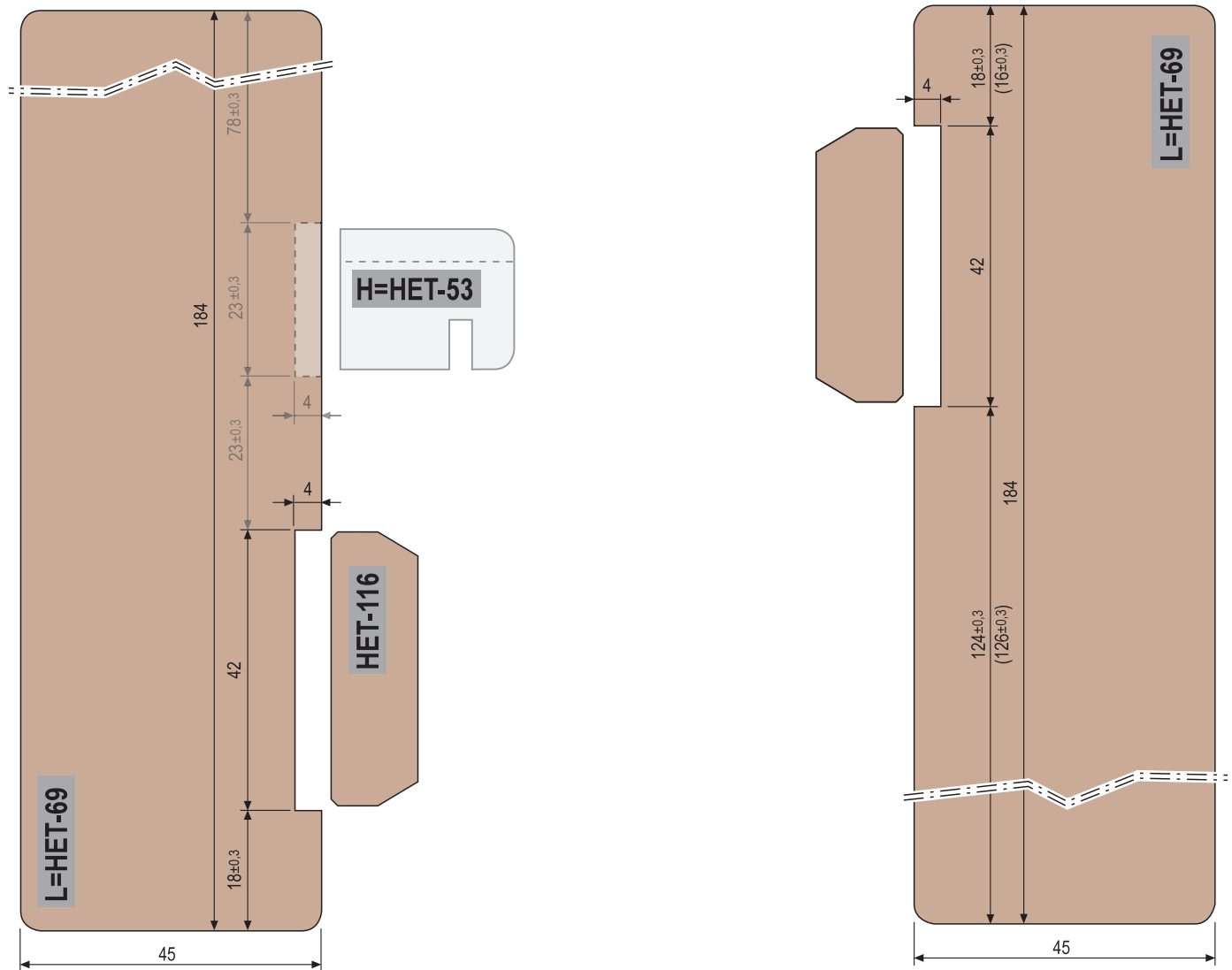

Lavorazioni legno: sezione orizzontale centrale

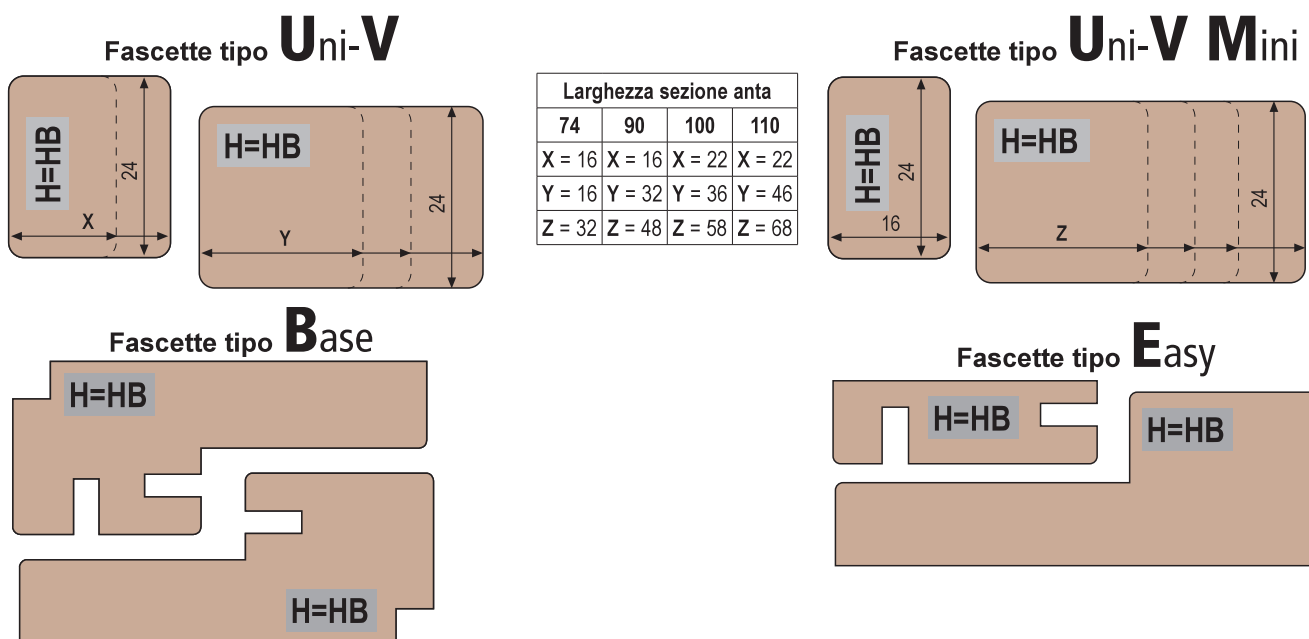

Wood millings: vertical section of upper frame transom

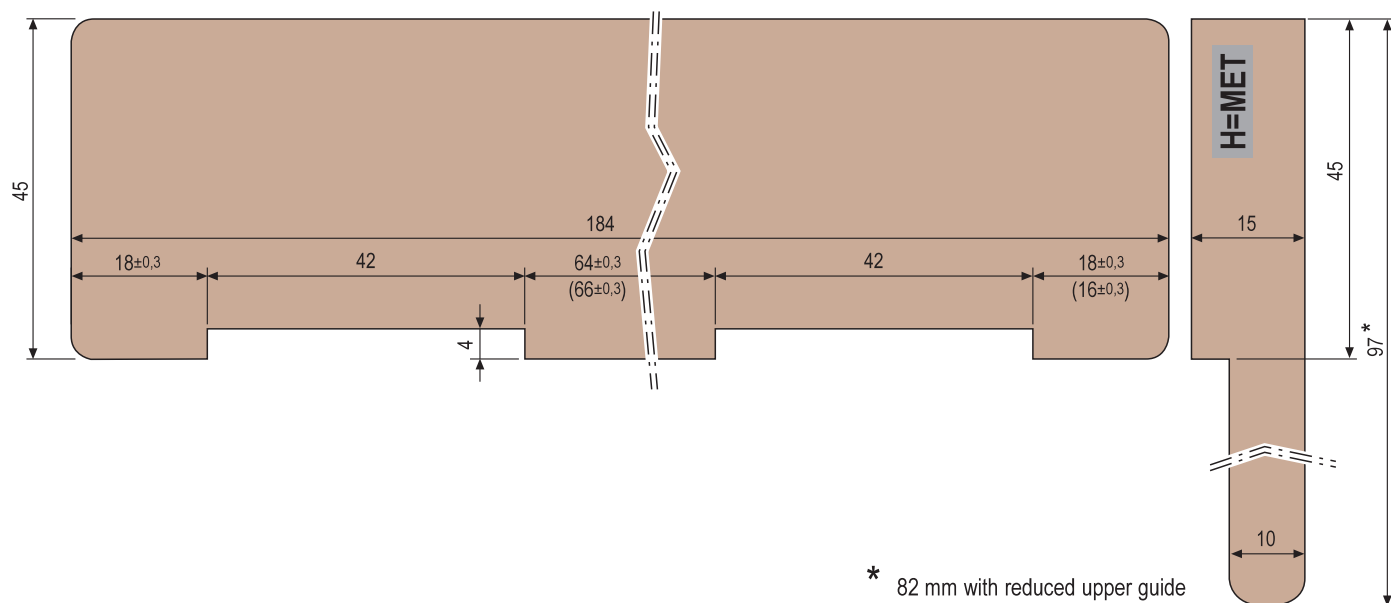

Details for layouts B & F

TOP LOCKING PROFILE



The top locking profile is not used. A top insulating pad positioned between top guides is used.

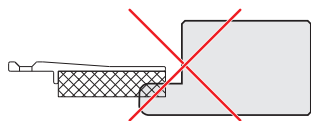

BRUSH LISTELS FOR DECOMPRESSION CHAMBER



The brush holder listel in the side point (layout B) is facultative.



COMPENSATOR CAP



The use of embedded reduced upper guides is not allowed.



COMPENSATOR CAP



Because the use of brush listel for decompression chamber is facultative, cut only if necessary.

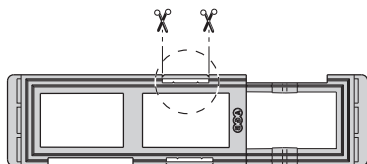

RAILS POSITION FOR SECOND SLIDING SASH

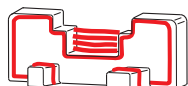

Connecting caps silicone detail for second sash rail

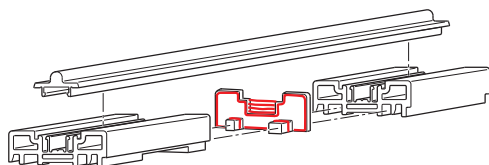

SECOND RAIL AND LOCKING PROFILE

2nd rail without grooves

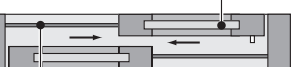
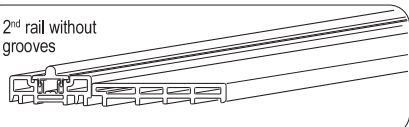

2nd rail with grooves



POSITION OF ANTI-DERAILED ADAPTERS



Install 2 devices on each central sash. Install 1 device on each side sash.

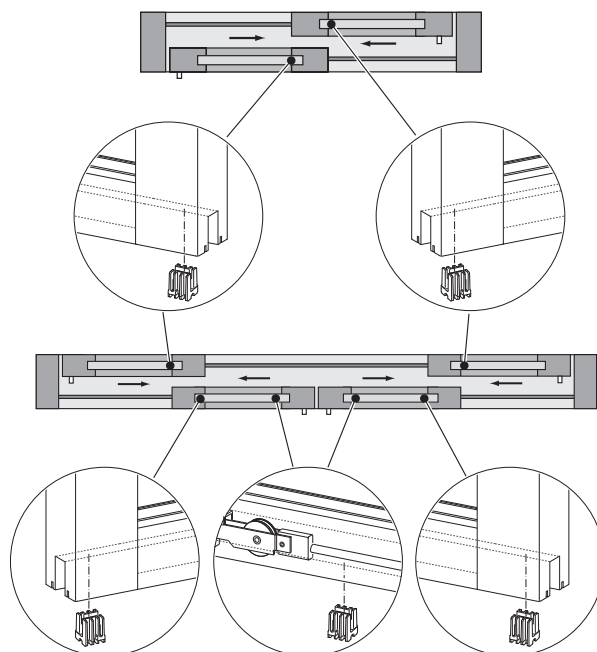

POSITION OF BOTTOM REAR SEALING PAD



Position the bottom rear pad between the cap and the anti-derailed adapter on external sashes.

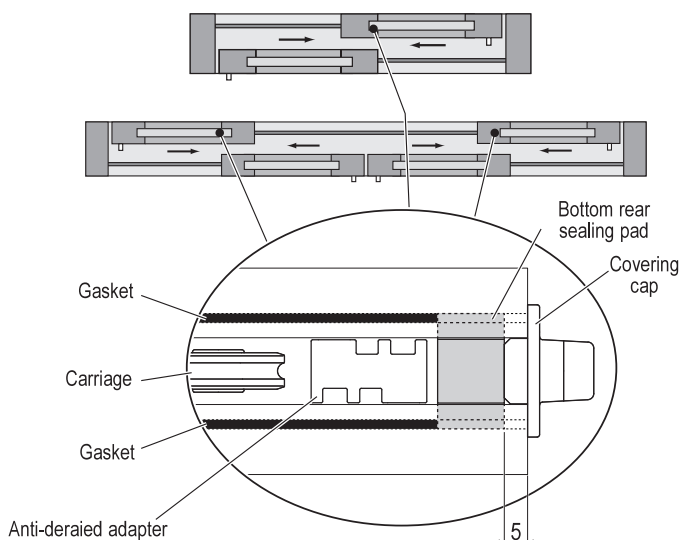

Silicone beadaround perimeter

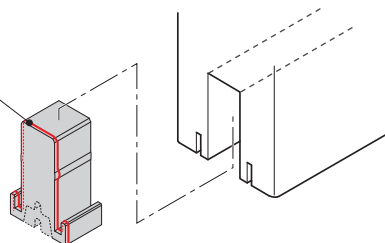

Formulas for accessories cut

| | | LAYOUT B | LAYOUT F |
|--|-----------|------------------------|------------------------|
| | XC | HB-94 | HB-94 |
| | XC S-Line | | |
| | | (2 pieces) MET-2xSMT-2 | (2 pieces) MET-2xSMT-2 |
| | | HET-116 | HET-116 |
| | | HB-65 | HB-65 |
| | XC | | |
| | XC S-Line | | |
| | XC | (2 pieces) 80 mm + | |
| | XC S-Line | (2 pieces) 80 mm + | |

| | |
|--|-------------|
| | MET |
| | MET-2xSMT-2 |
| | HB-14 |
| | HB-4 |
| | HB-14 |

| | | LAYOUT B | | | |
|--|------------------------|--------------|-------------------|-------------|-------------|
| | | Uni-V | Uni-V Mini | Easy | Base |
| | Sash section width 74 | LB-87 | LB-74+5 | LB-76 | LB-71 |
| | Sash section width 90 | | | | |
| | Sash section width 100 | LB-93 | LB-90+5 | LB-76 | LB-71 |
| | Sash section width 110 | | | | |

| | | LAYOUT F | | | |
|--|------------------------|------------------|--------------------|------------------|------------------|
| | | Uni-V | Uni-V Mini | Easy | Base |
| | Sash section width 74 | (2 pieces) LB-87 | (2 pieces) LB-74+5 | (2 pieces) LB-76 | (2 pieces) LB-71 |
| | Sash section width 90 | | | | |
| | Sash section width 100 | (2 pieces) LB-93 | (2 pieces) LB-90+5 | (2 pieces) LB-76 | (2 pieces) LB-71 |
| | Sash section width 110 | | | | |

LAYOUTS A & E, LAYOUTS B & F - ASSEMBLY OPERATIONS

Threshold fastening

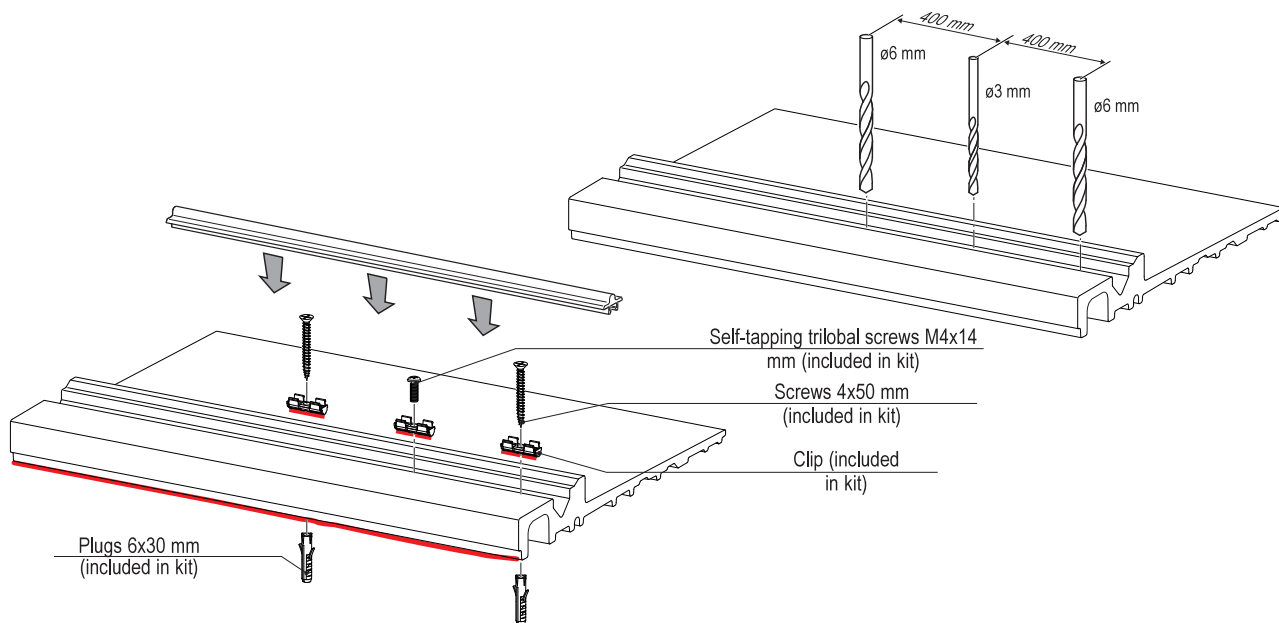

Caps application under the jambs

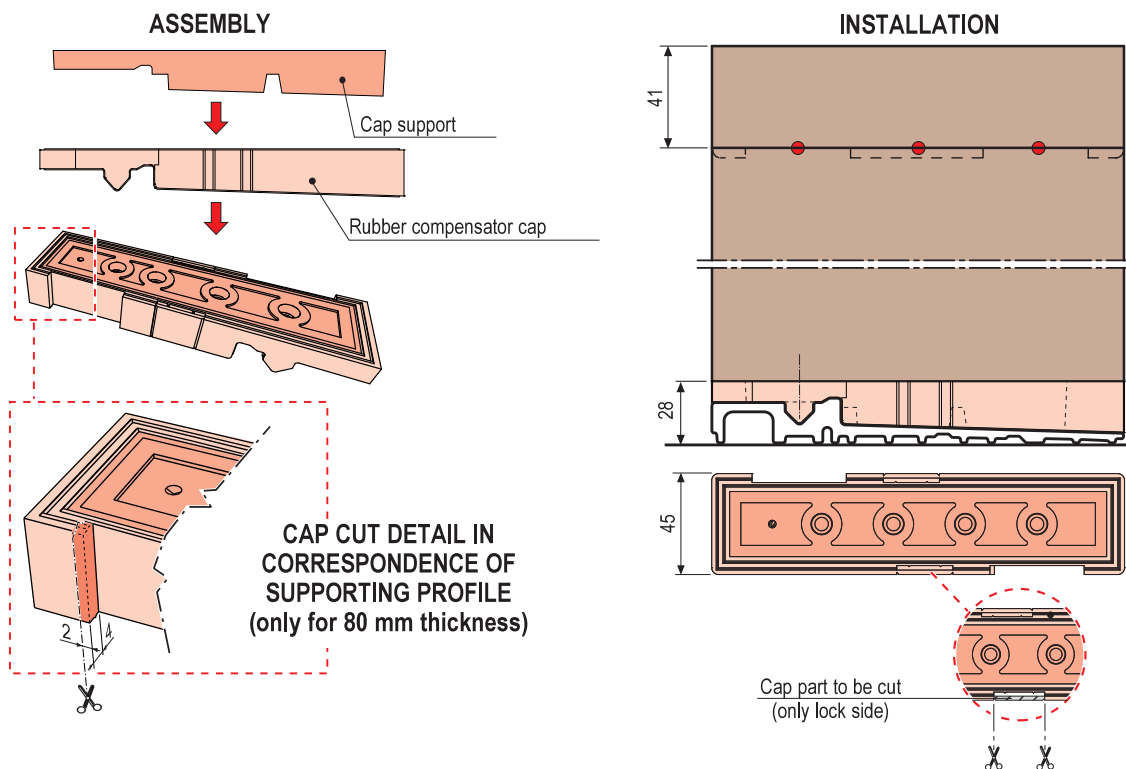

Pad application on central jambs

Before installing the lower pads, make a silicone bead around perimeter as indicated.

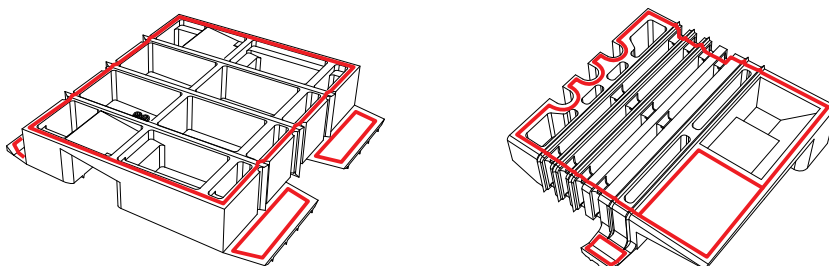

Positioning of central profile and point on sliding sash - layouts E-F

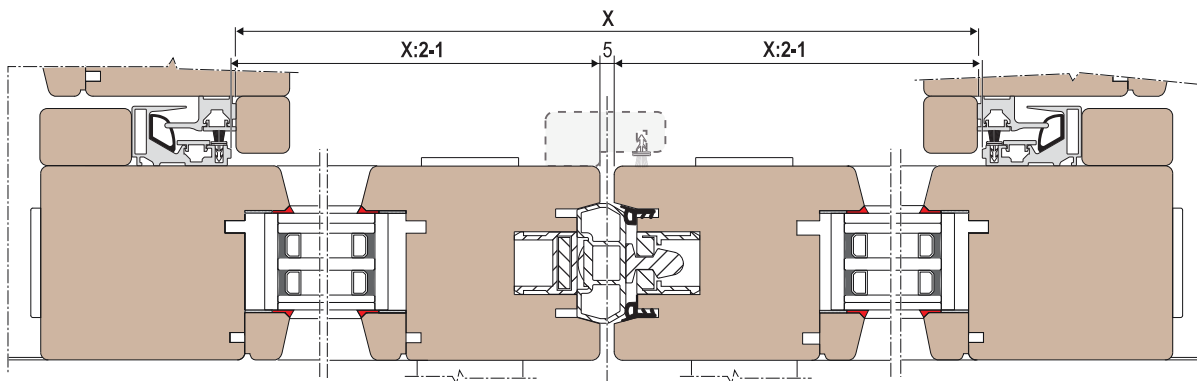

Lock holes

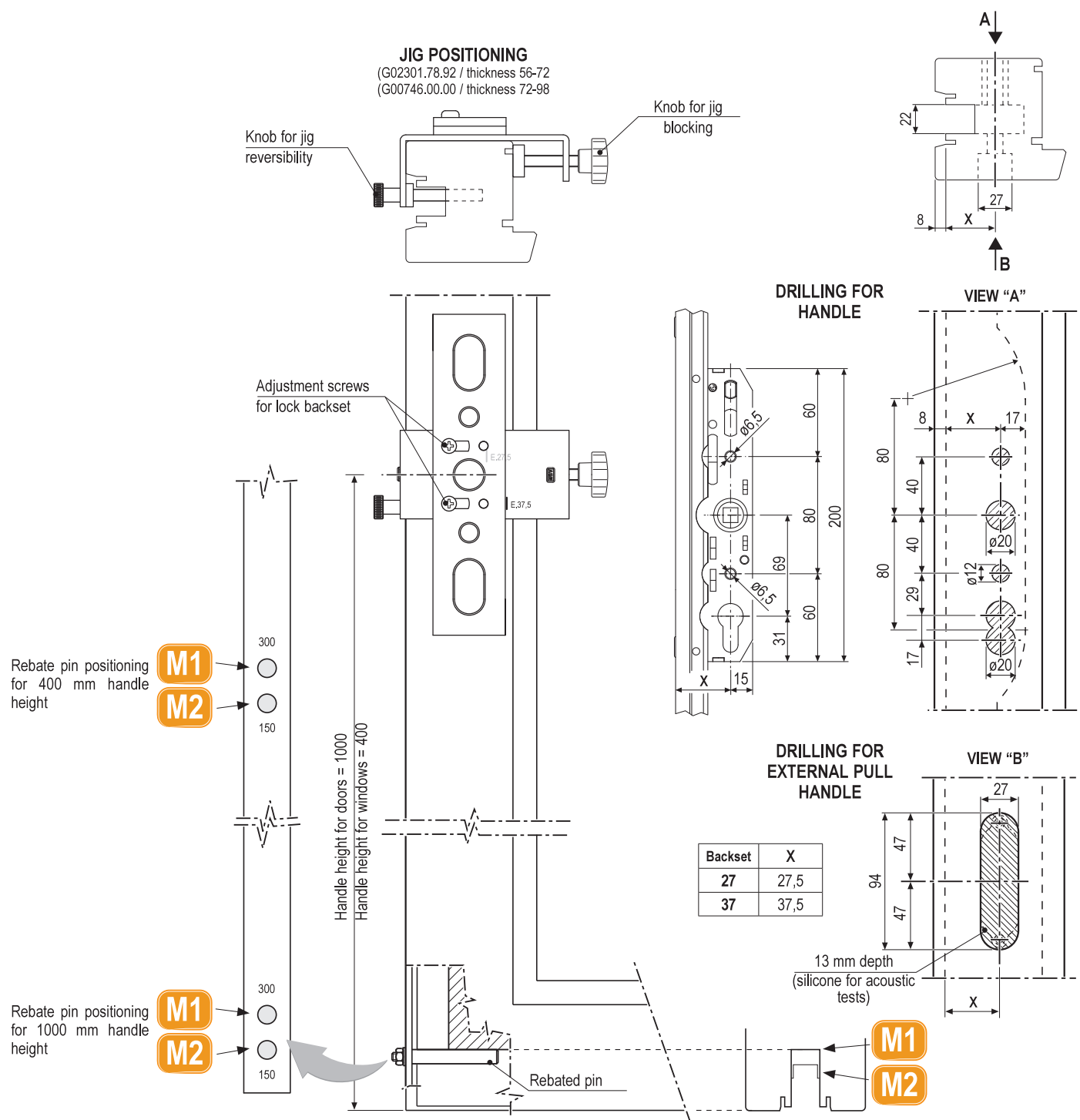

Accessories for single sash configuration with guide 22x22

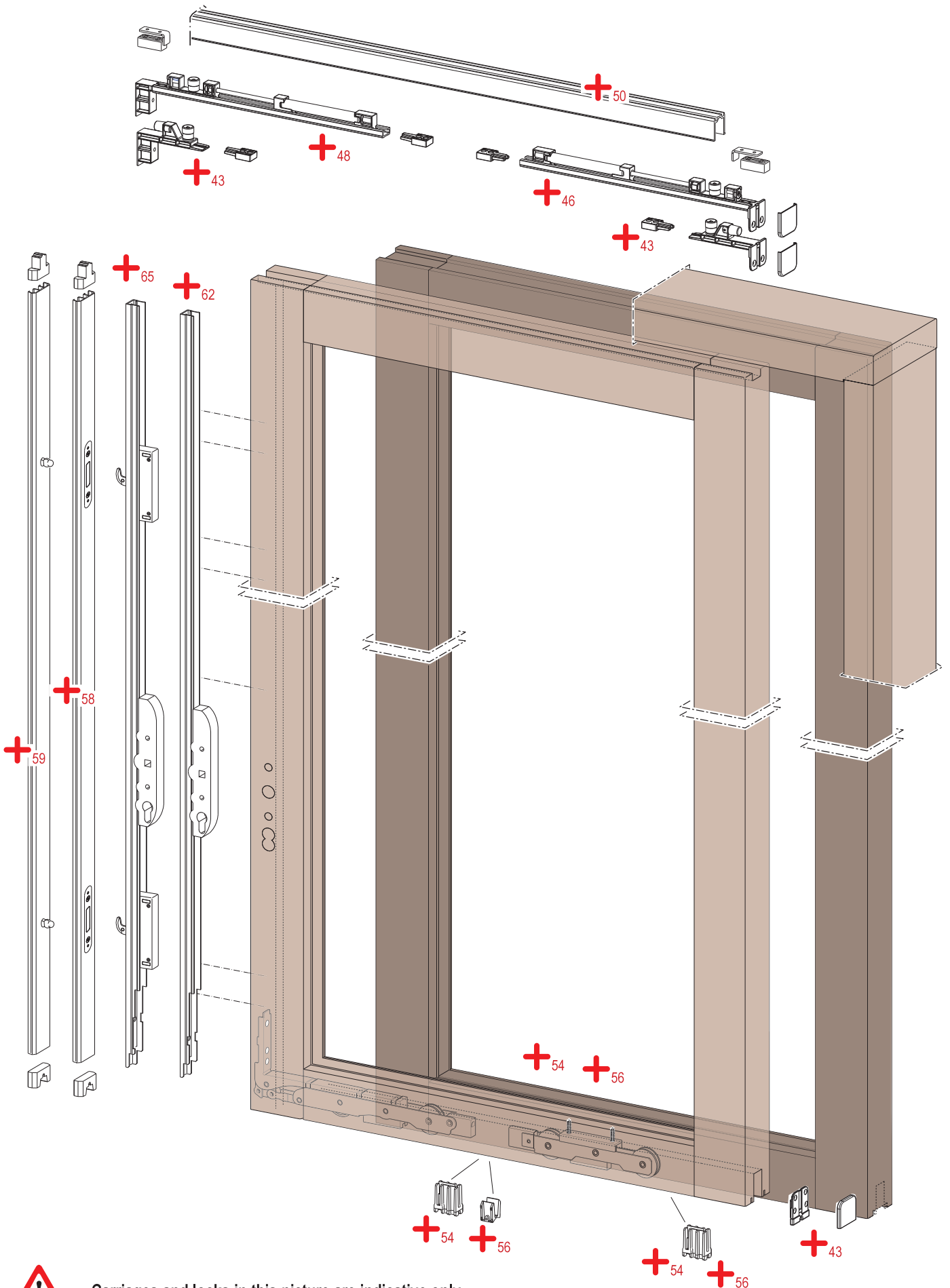

Accessories for single sash configuration with guide 22x13

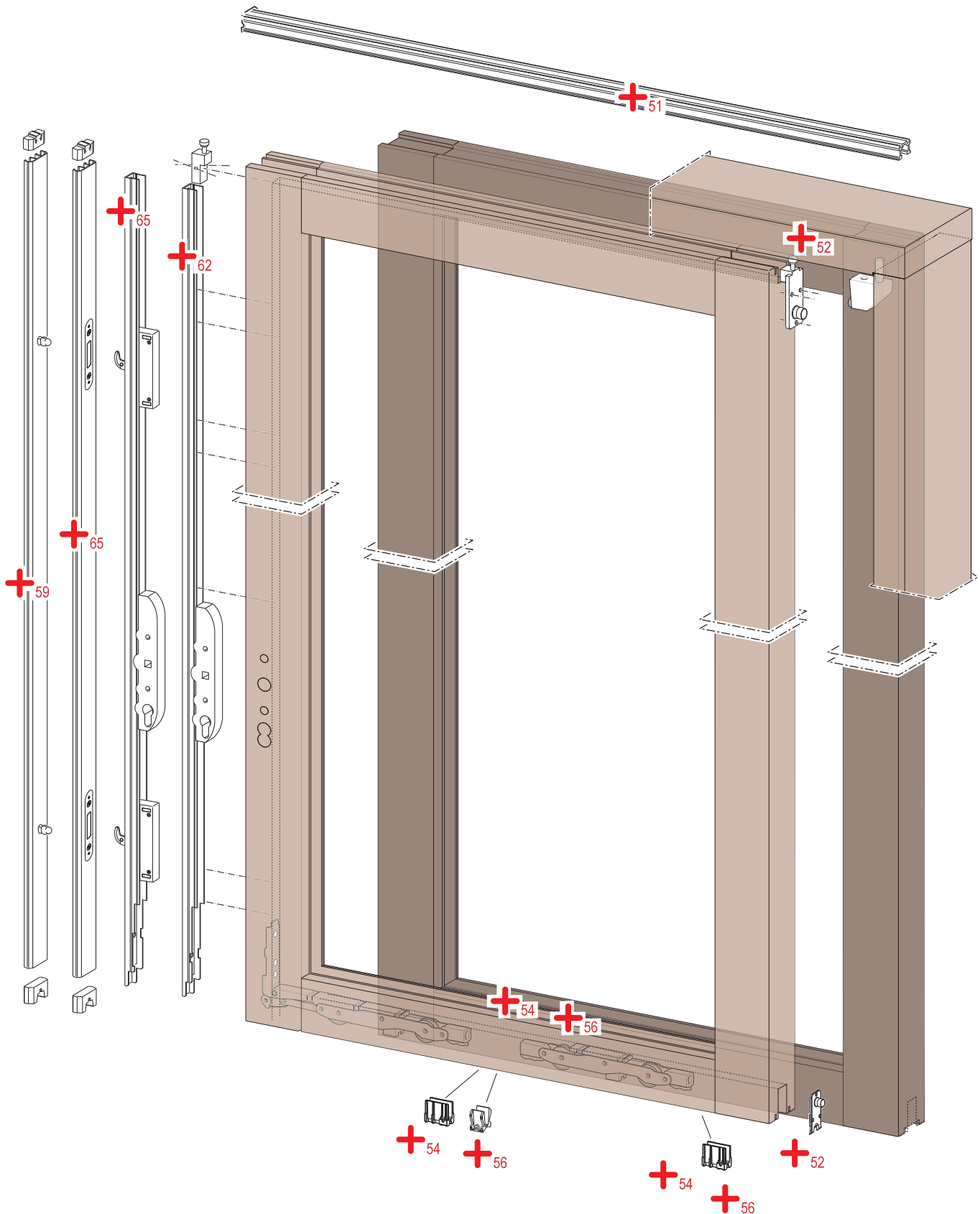

Carriages and locks in this picture are indicative only.

Accessories for coaxial sashes configuration with guide 22x13

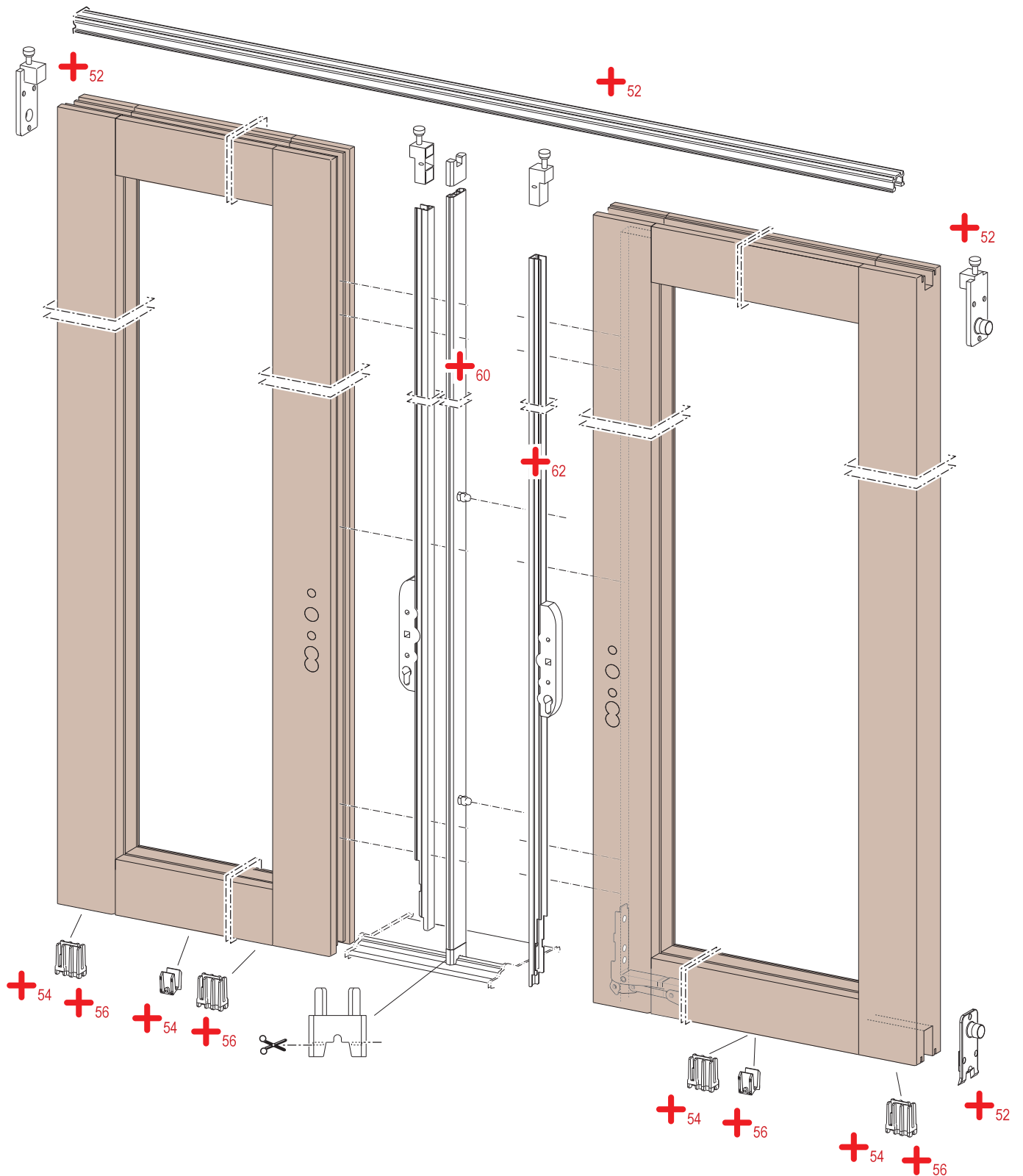

Carriages and locks in this picture are indicative only.

Accessories for coaxial sash configuration with guide 22x22

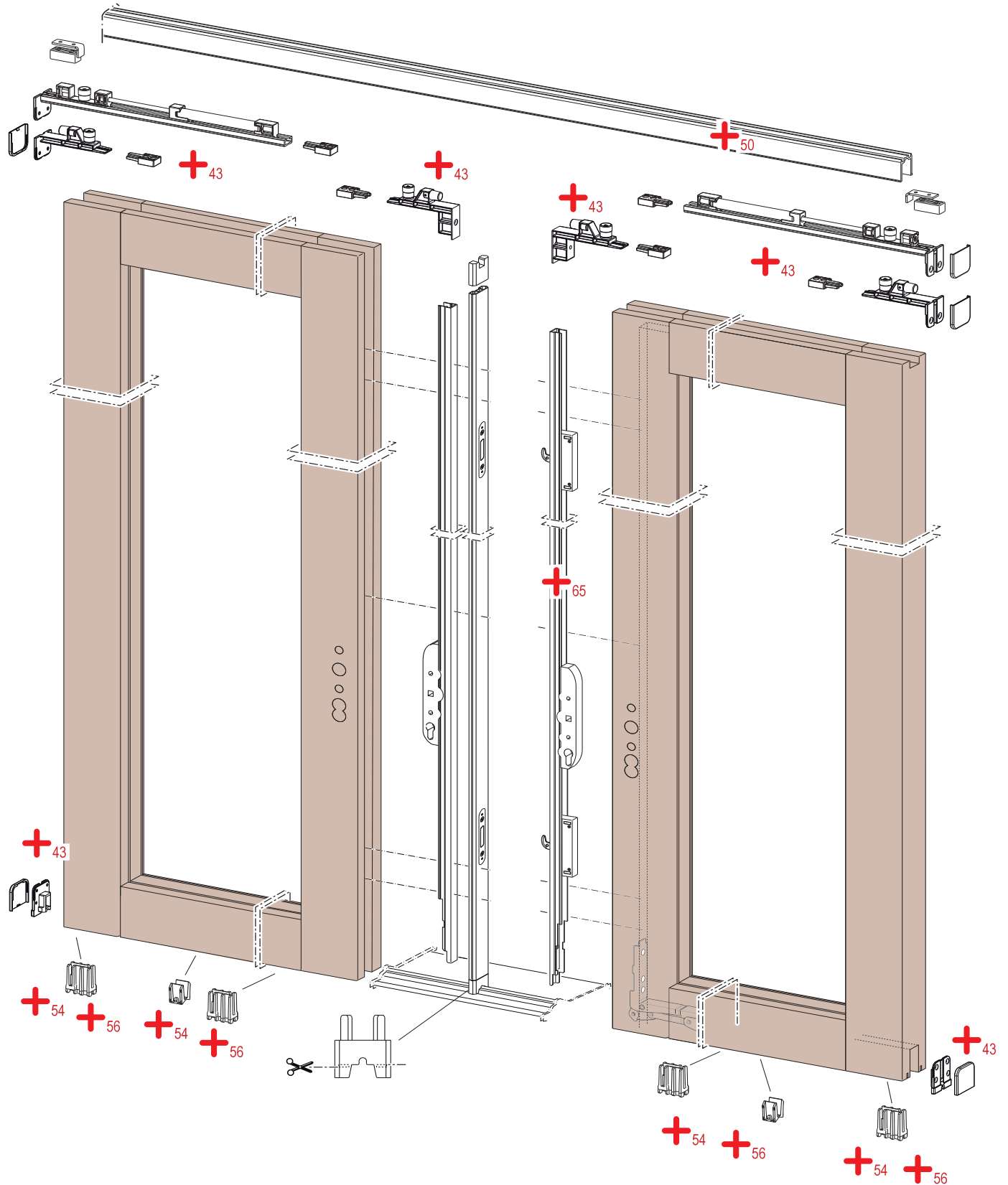

Carriages and locks in this picture are indicative only.

Sash assembly

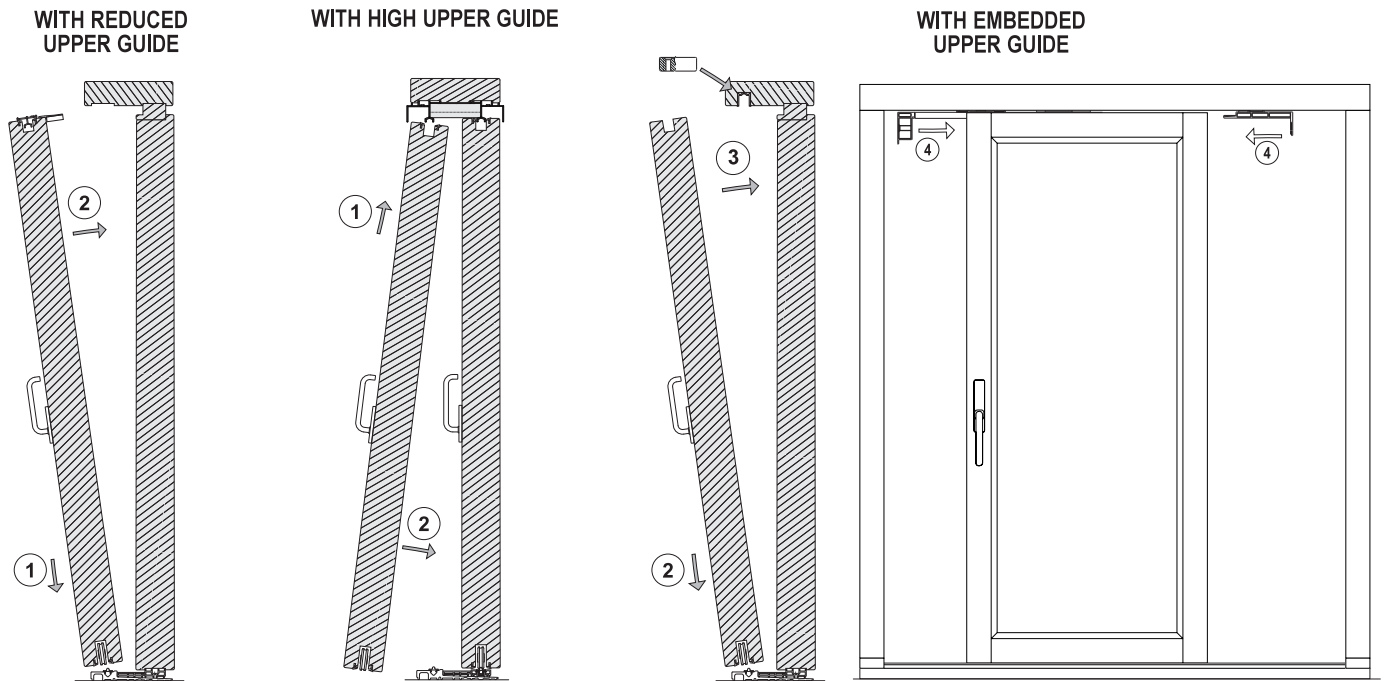

Locking pins assembly

+ 59

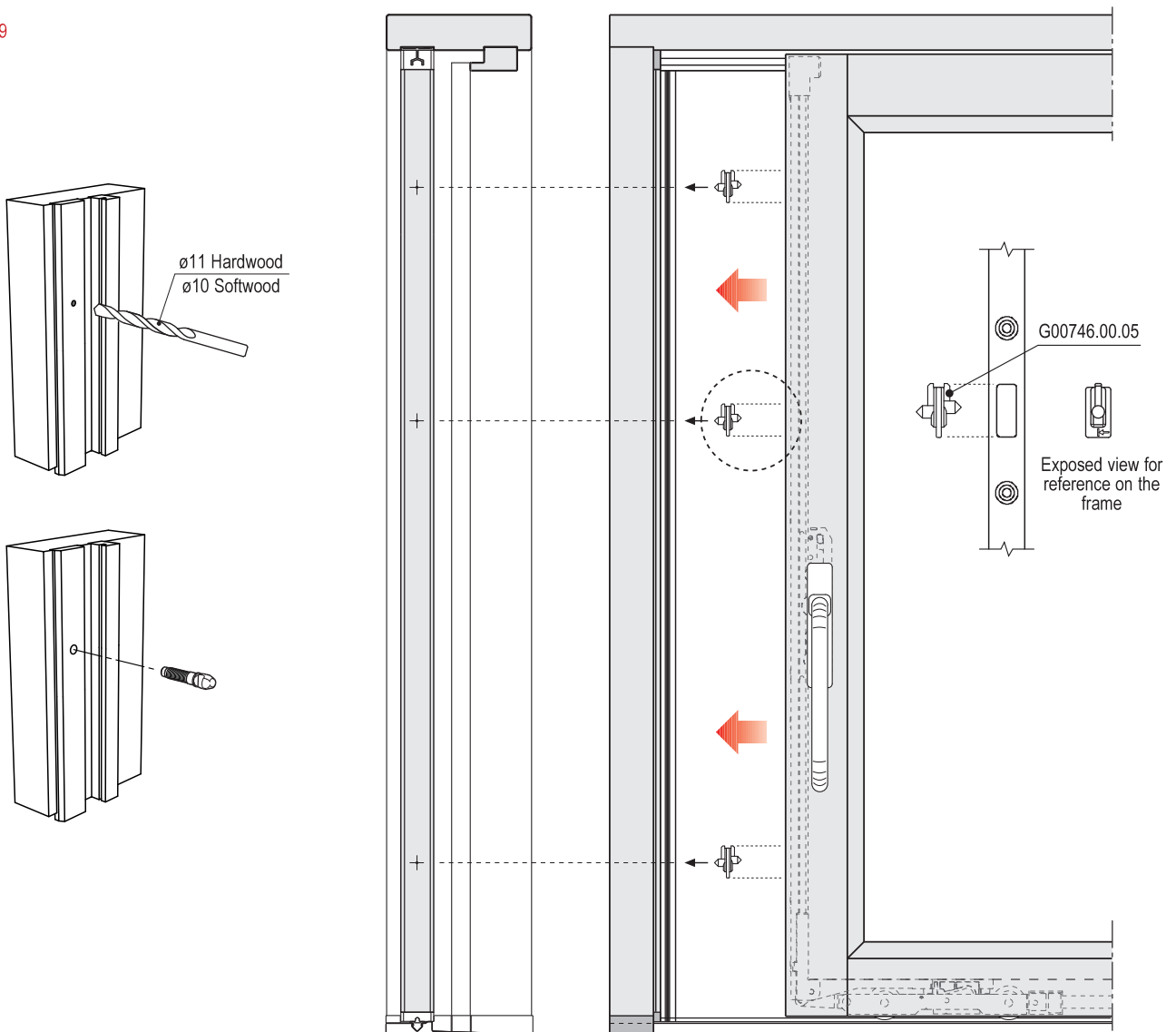

Use of gas spring kit

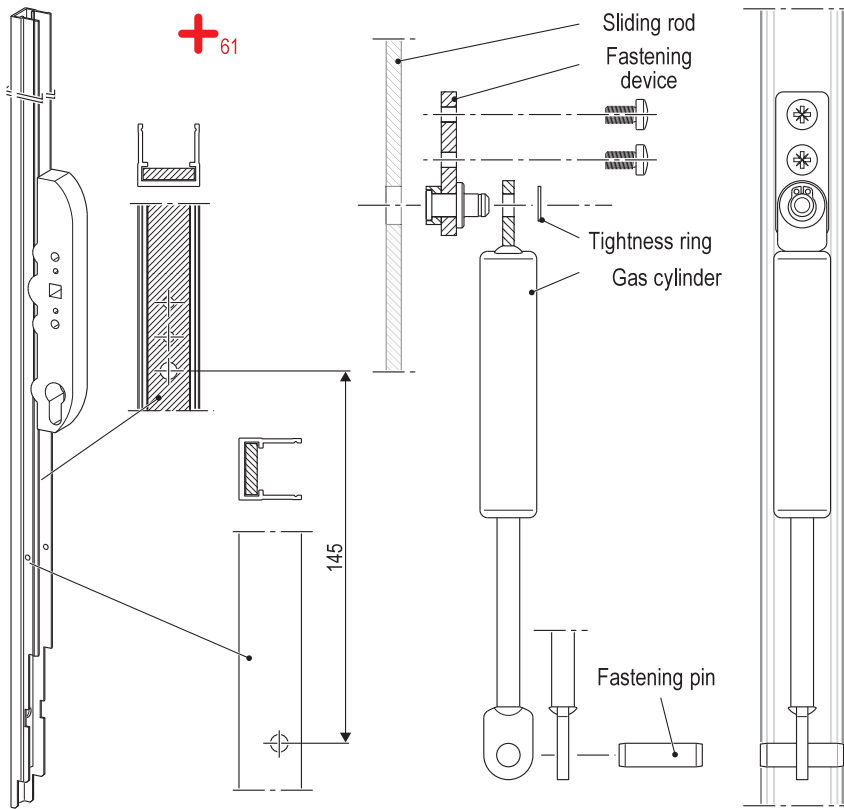

STEPS FOR THE PRODUCTION PROCESS CONTROL (FPC)

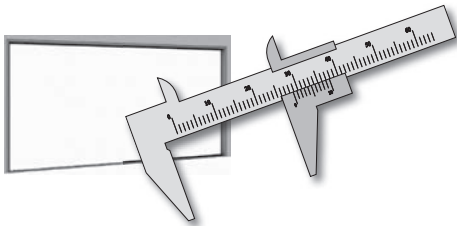

Frame components measurement and solutions for air-water tightness

- 1 - Find the length and width of upper transom and vertical jambs.
- 2 - Check the length and depth of millings to host the aluminium upper guide and wooden listels are compliant to what indicated in this technical manual.
- 3 - Check the width and length of listels.
- 4 - Check that the length of threshold, the sliding profile and the glass holder profile corresponds to the indications of this technical manual.

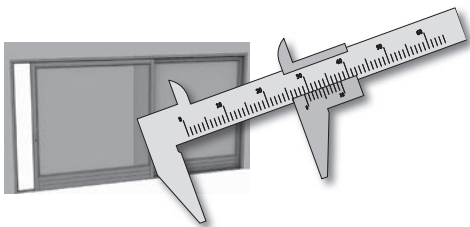

Sashes components measurement and solutions for air-water tightness

- 1 - According to the frame measurements, please calculate the sashes measurements according to the indications reported in the technical manual (LxH) and check that sash dimensions are compliant to the ones calculated before.
- 2 - Check the sashes orthogonality (square) measuring the diagonals, it is very important they are equal for the correct functioning and closing.
- 3 - Check the sash adapter is exactly the one indicated in this manual.
- 4 - Check the millings width for the carriages housing and check that they are in the middle of the sash thickness.
- 5 - Check the depth and width of millings to host the gaskets checking the status, they can't have dirt or glue/paint.
- 6 - Check the depth and position the lock milling.
- 7 - Check the coplanarity of jamb/lower transom joints, eventually level with stucco in order to keep the tightness strong.
- 8 - The double glazing glass has to be siliconed flush to the rebate, perimetrically from outside, on wooden frames and aluminium glass holder profile.
- 9 - Silicone even on internal glass holder or use specific gaskets.
- 10 - Make a silicone bead around perimeter inside the external lower gasket groove before inserting it.

TECHNICAL ATTACHMENTS

Caps kit for embedded upper guide 22x22

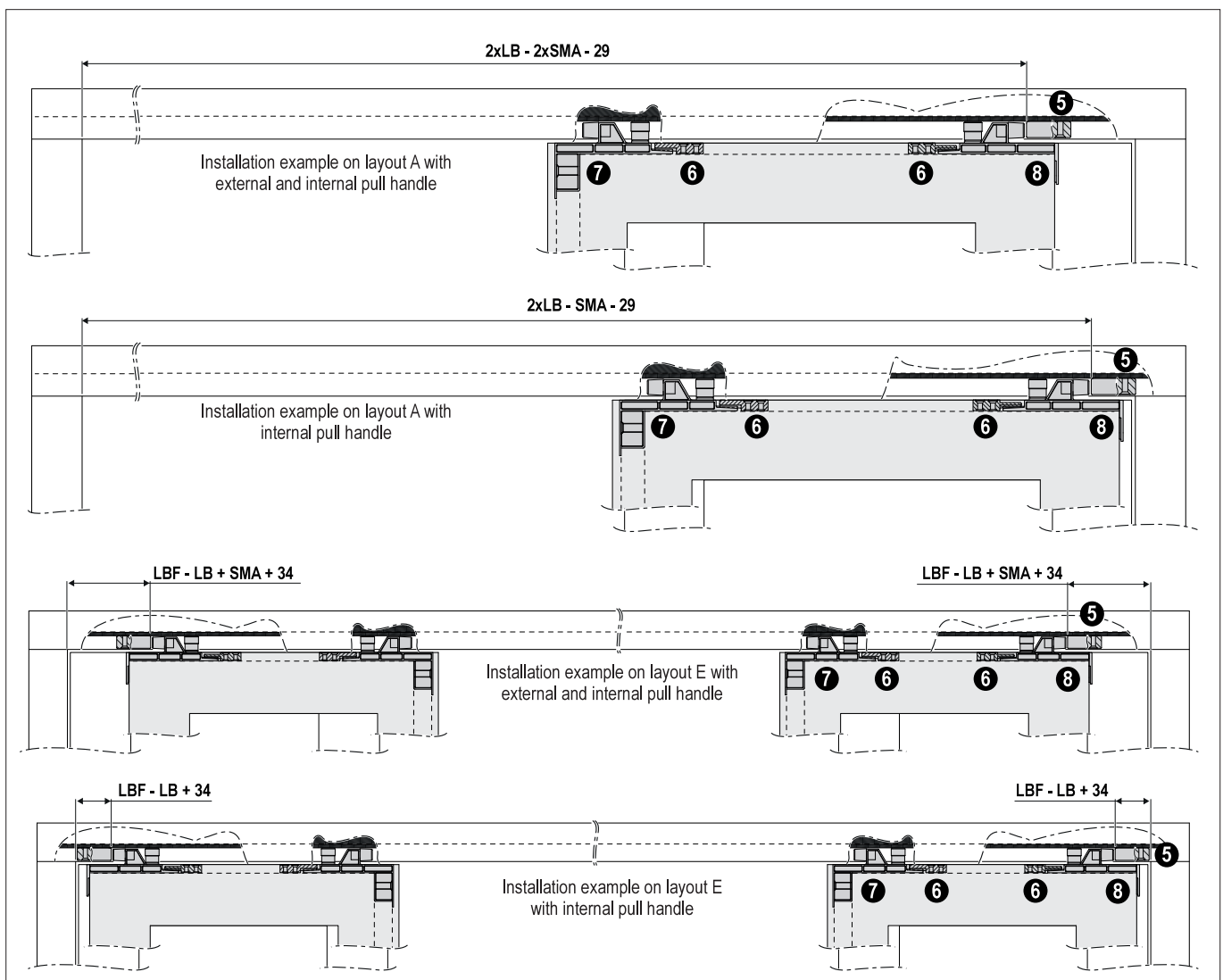
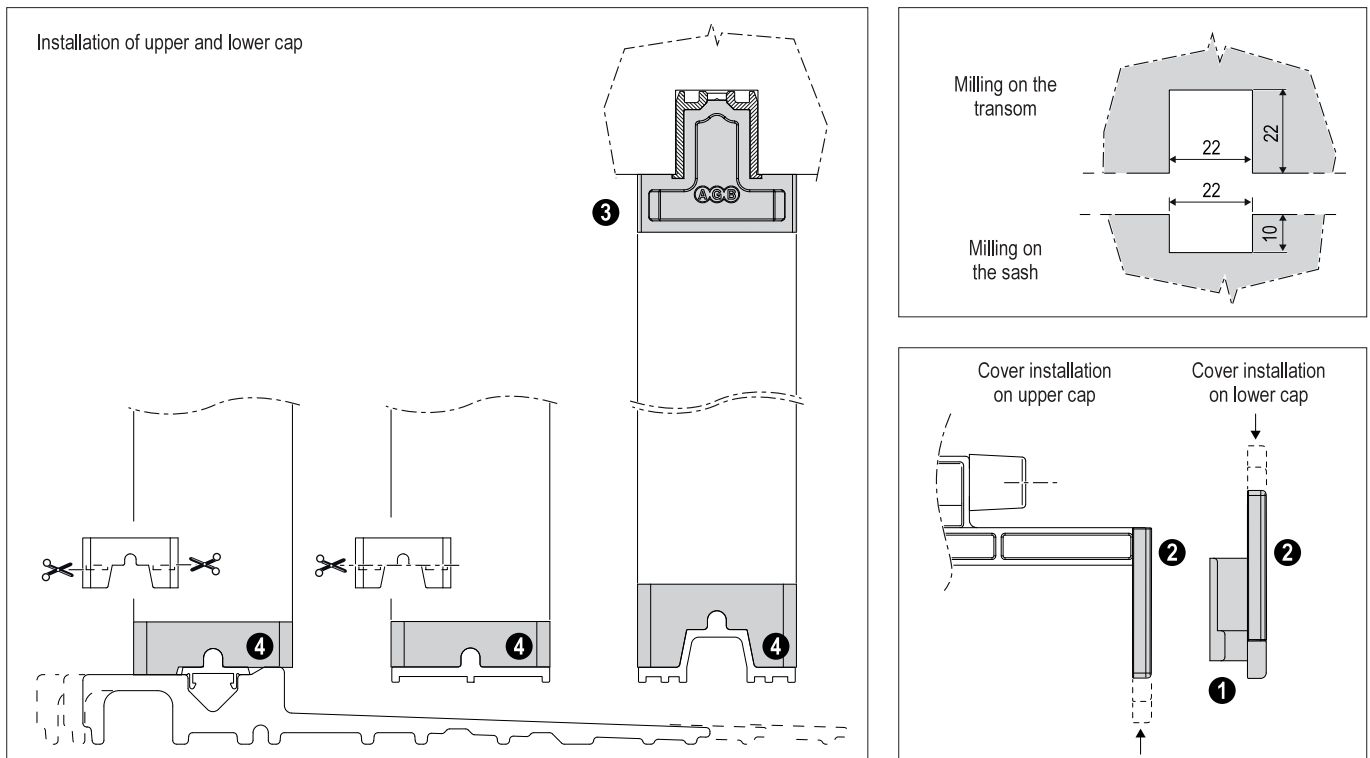

Caps kit for embedded upper guide 22x22

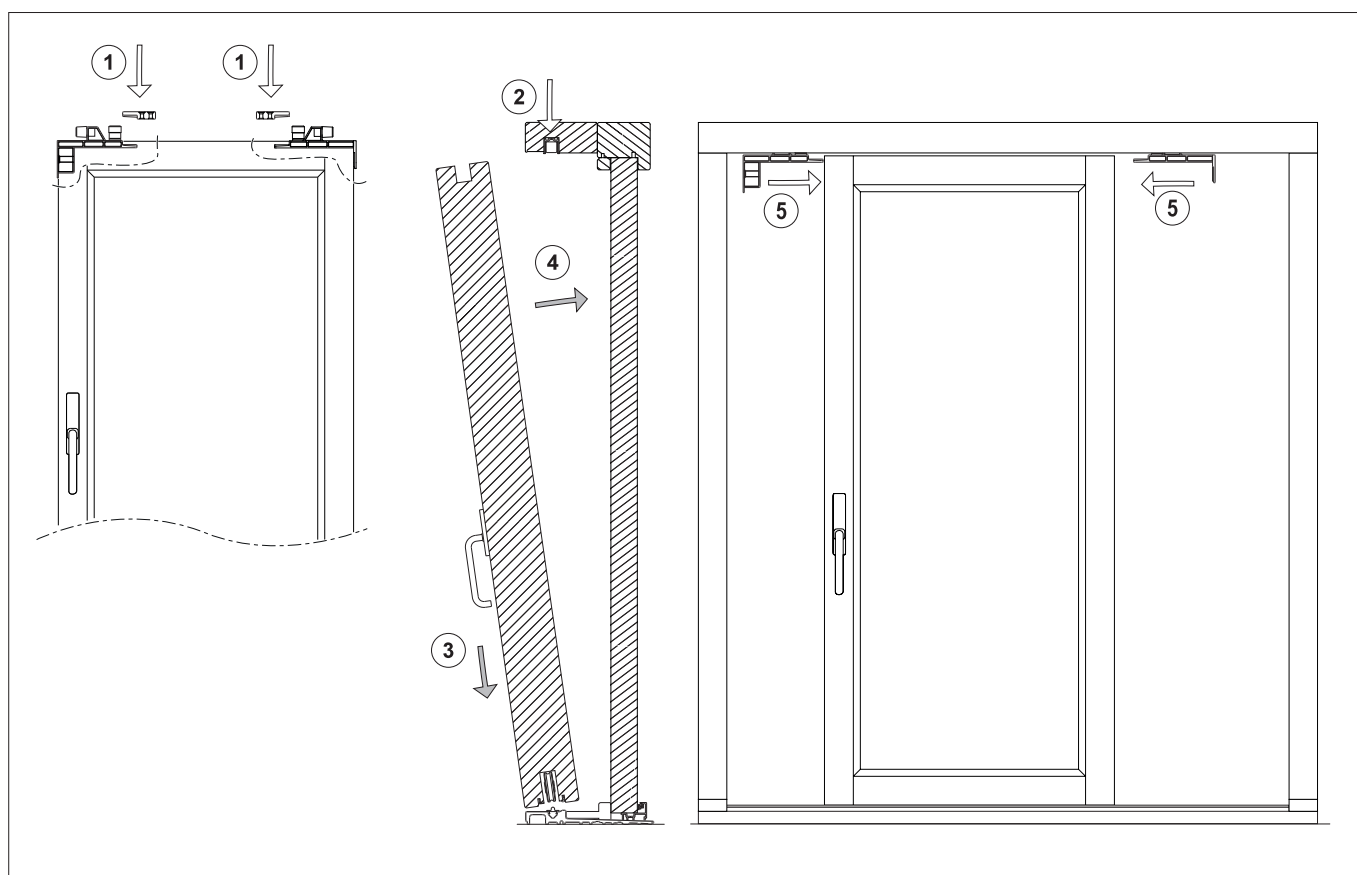

- ① Using the glider/s as a jig, fasten the hold device/s into the sliding sash, not installed yet; then, remove the caps;
- ② Place the device/s in the right position indicated in this technical documentation;
- ③ Place the sash on the rail with the carriages in opening position;
- ④ Place the sash in vertical position;
- ⑤ Fasten the gliders on the sliding sash.

| Article | Grey RAL 7035 | Black |
|---|---------------|--------------|
| Caps kit for embedded upper guide 22x22 | G00232,00,86 | G00232,00,93 |

Damper kit with opening brake

| Article | Ref. | Description | Material | Use | Fastening |
|---------------------------------|------|---|----------------------------------|---|-----------------|
| Rear cap with glider as a guide | 1 | Sliding glider and opening brake. | Plastic material / zamak / steel | To fasten the sash in opening. | 4x30 mm screws. |
| Magnetic contrast | 2 | It allows the damper activation in closing/opening. | Steel | To be applied under the contrast as a guide if you use the brake. | 4x30 mm screws. |

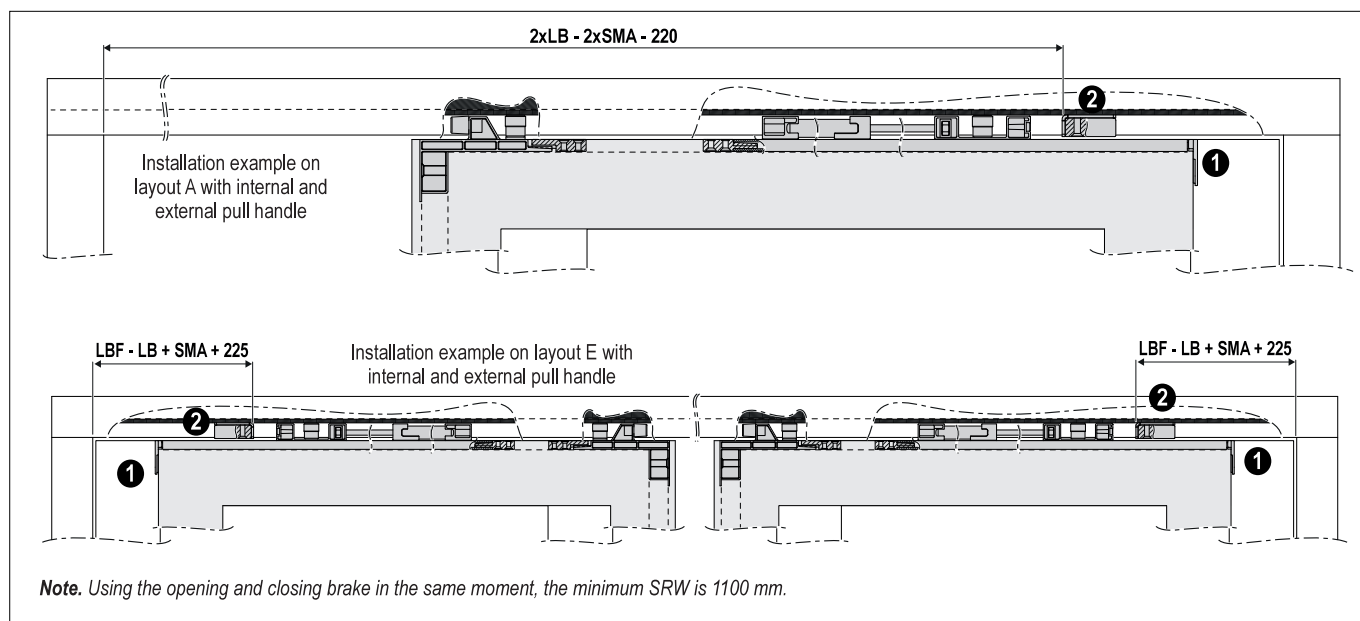
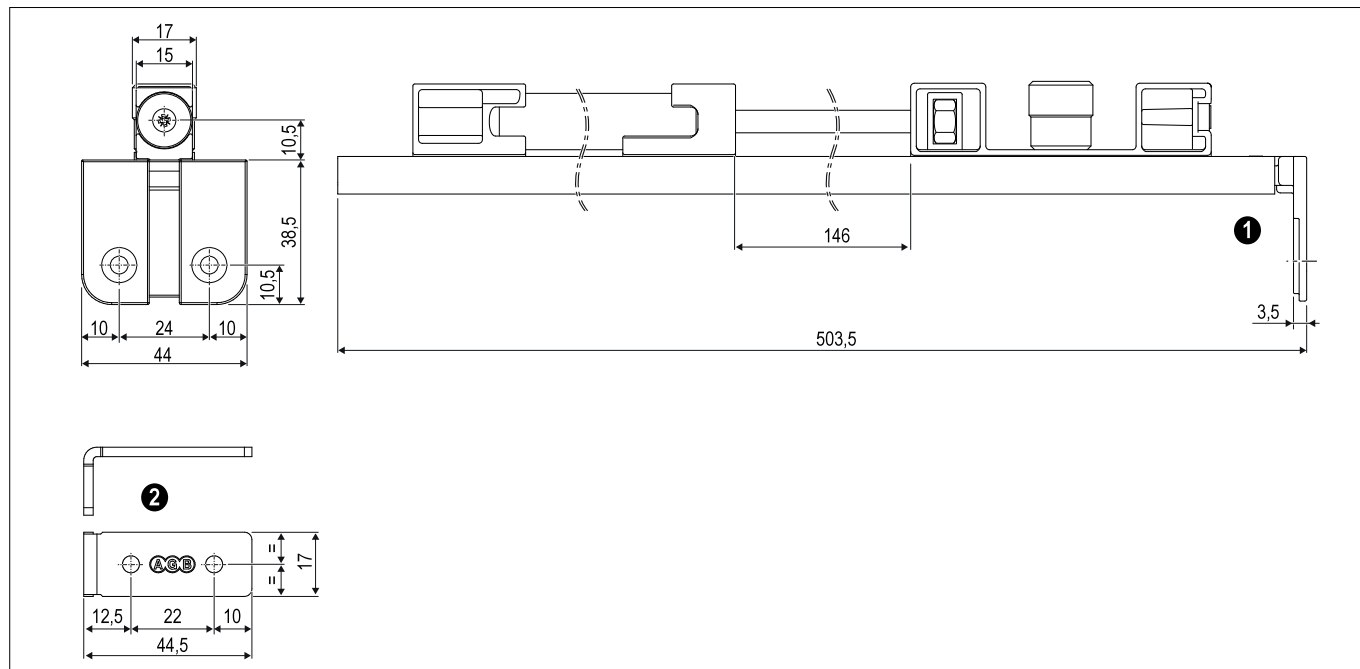

Damper kit with opening brake

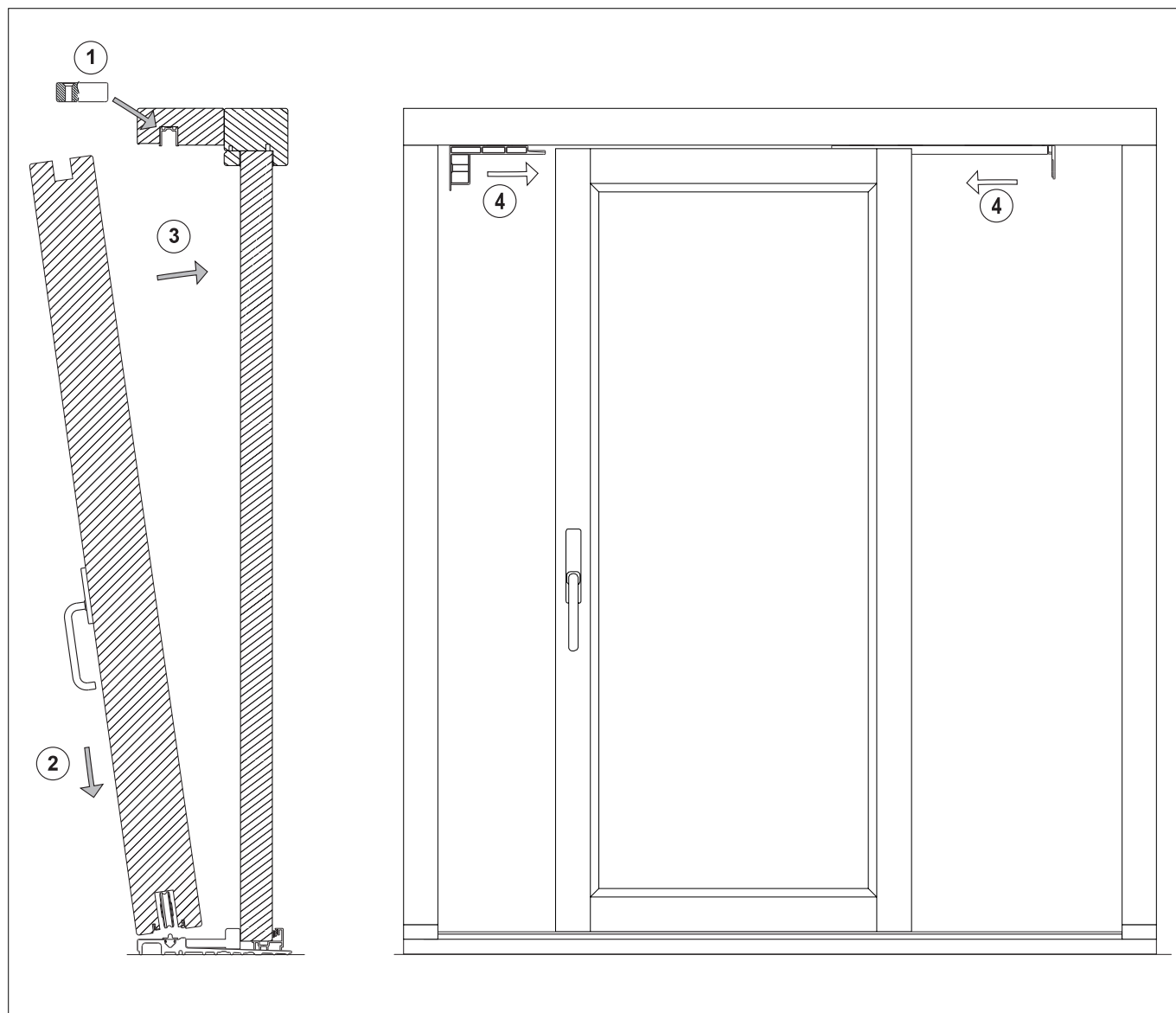

- ① Place the device/s in the right position indicated in this technical documentation;
- ② Place the sash on the rail with the carriages in opening position;
- ③ Place the sash in vertical position;
- ④ Fasten the gliders on the sliding sash.

| Article | Grey RAL 7035 | Black |
|-----------------------------|---------------|--------------|
| Loading capacity 80-200 kg | G00232.13.86 | G00232.13.93 |
| Loading capacity 200-440 kg | G00232.14.86 | G00232.14.93 |

Damper kit with closing brake

| Article | Ref. | Description | Material | Use | Fastening |
|------------------------|------|--|----------------------------------|---|-----------------|
| Front cap with damper | ❶ | Sliding glider and closing brake. | Plastic material / zamak / steel | To stop the sash in opening. | 4x30 mm screws. |
| Magnetic contrast | ❷ | It allows the damper activation in opening. | Steel | To be applied under the contrast as a guide if you use the brake. | 4x45 mm screws. |
| Device for frame guide | ❸ | Rebate for the glider pad or for the damper. | Zamak | - | 4x45 mm screws. |

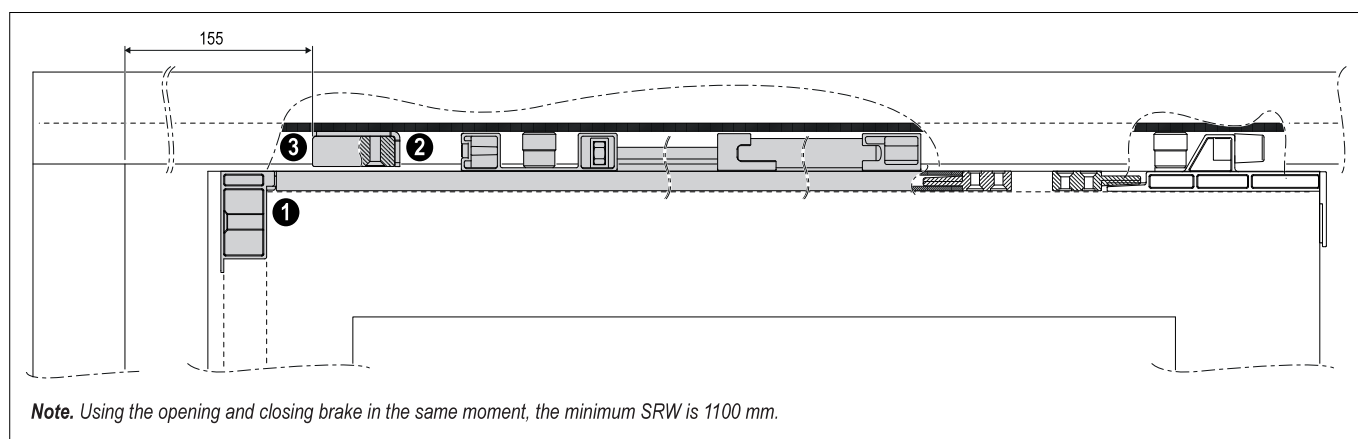
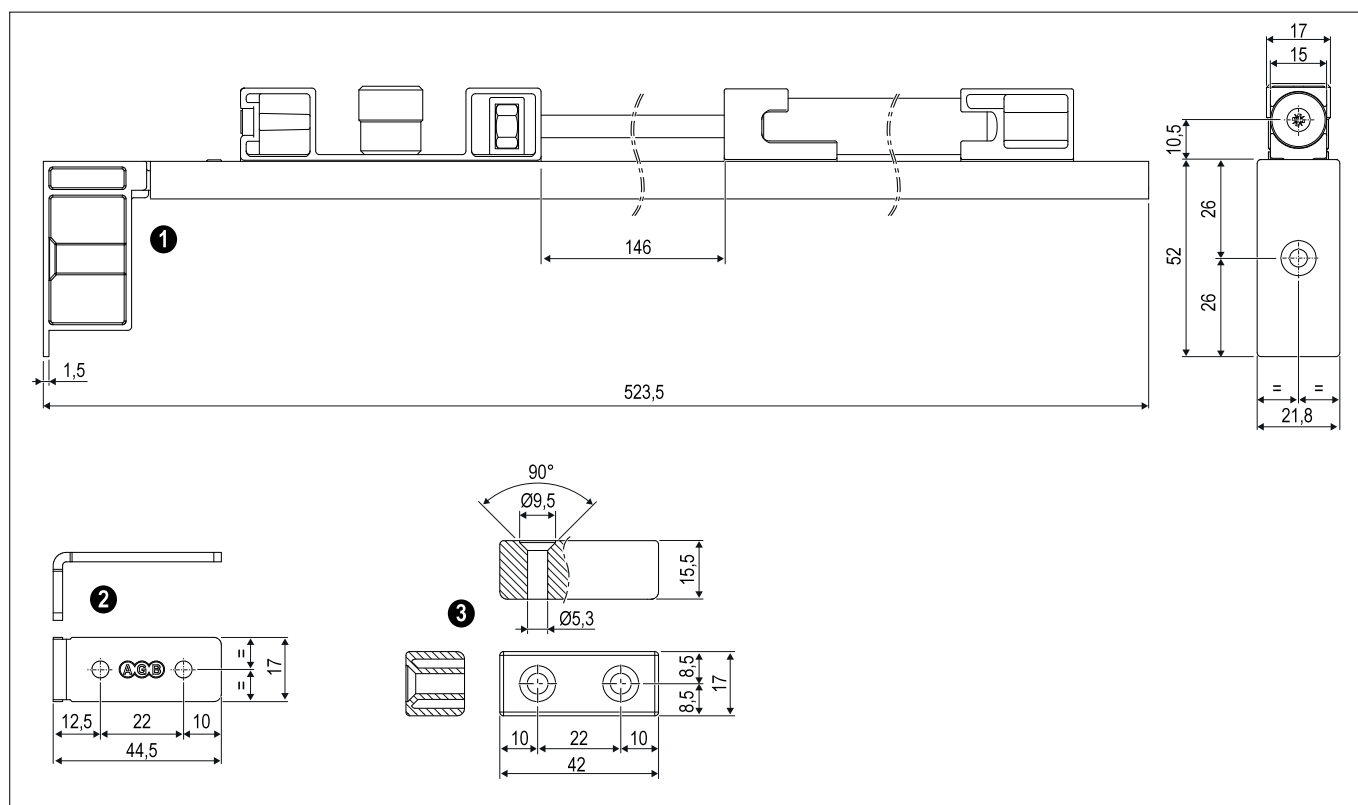

Damper kit with closing brake

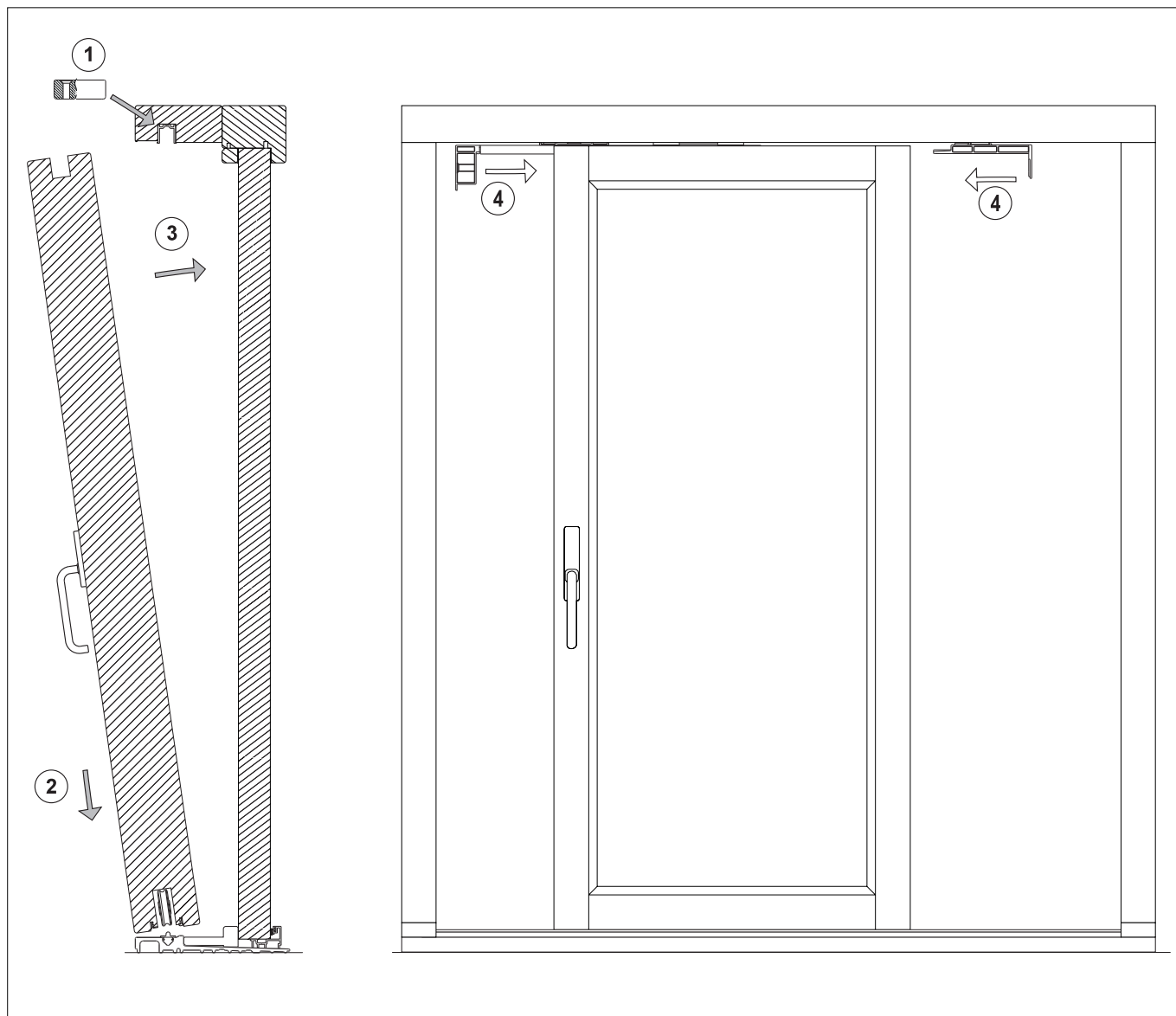

- ① Place the device/s in the right position indicated in this technical documentation;
- ② Place the sash on the rail with the carriages in opening position;
- ③ Place the sash in vertical position;
- ④ Fasten the gliders on the sliding sash.

| Article | Grey RAL 7035 | Black |
|-----------------------------|---------------|--------------|
| Loading capacity 80-200 kg | G00232.11.86 | G00232.11.93 |
| Loading capacity 200-440 kg | G00232.12.86 | G00232.12.93 |

Embedded upper guide 22x22

| Article | Ref. | Description | Material | Use | Fastening |
|----------------------|----------|--|-----------|---|-----------------|
| Embedded upper guide | 1 | Guide for sliding gliders of the sliding sash, compatible with AGB systems of closing/opening brake. | Aluminium | Insert in the dedicated milling of the frame upper transom. | 4x25 mm screws. |

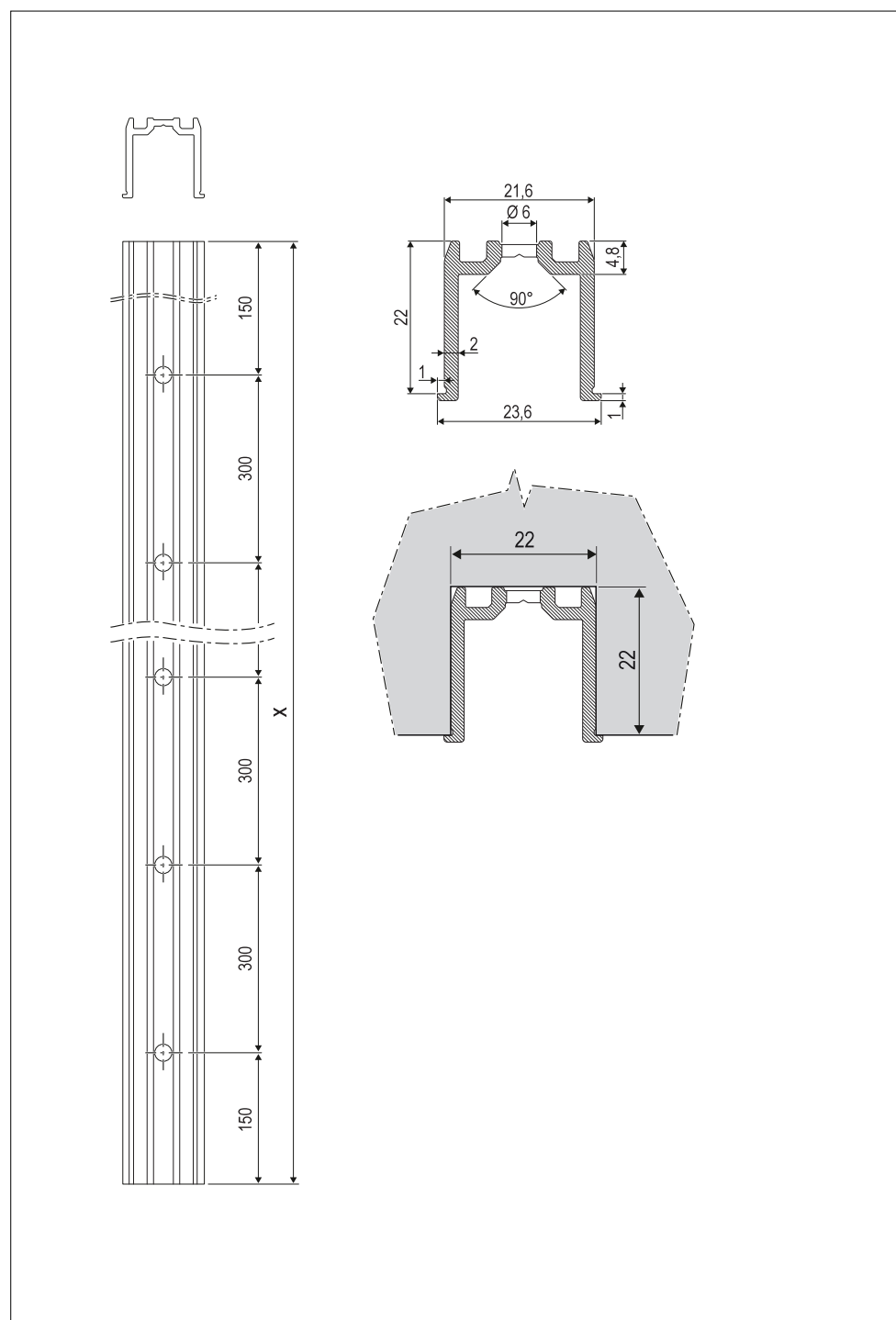

| Ref. | Article | Article code, in Silver | Article code, in Electrocolour | X |
|----------|----------------------|-------------------------|--------------------------------|------|
| 1 | Embedded upper guide | G01002.01.01 | G01002.01.02 | 3000 |
| | | G01002.02.01 | G01002.02.02 | 4000 |
| | | G01002.03.01 | G01002.03.02 | 5000 |
| | | G01002.04.01 | G01002.04.02 | 6000 |
| | | G01002.05.01 | G01002.05.02 | 7000 |

Embedded upper guide 22x13

| Article | Ref. | Description | Material | Use | Fastening |
|----------------------------|------|---|-----------|---|-----------------|
| Embedded upper guide 22x13 | ❶ | Guide for sliding gliders of the movable rod. | Aluminium | Insert in the dedicated milling of the frame upper transom. | 4x25 mm screws. |

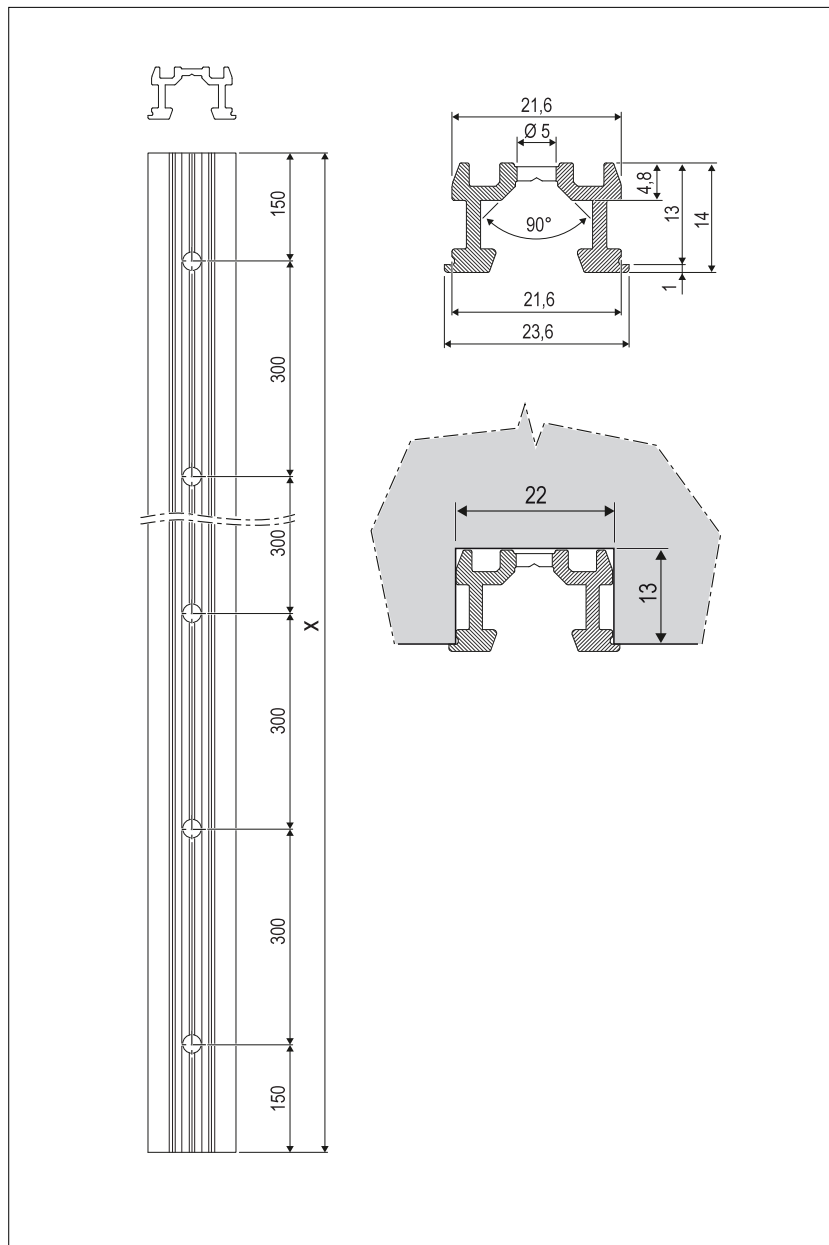

| Ref. | Article | Article code, in Silver | Article code, in Electrocolour | X |
|------|----------------------------|-------------------------|--------------------------------|------|
| ❶ | Embedded upper guide 22x13 | G01000.01.01 | G01000.01.02 | 3000 |
| | | G01000.02.01 | G01000.02.02 | 4000 |
| | | G01000.03.01 | G01000.03.02 | 5000 |
| | | G01000.04.01 | G01000.04.02 | 6000 |
| | | G01000.14.01 | G01000.14.02 | 7000 |

Caps kit for embedded upper guide 22x13 - low rail

| Article | Ref. | Description | Material | Use | Fastening |
|--------------------------------------|----------|--|------------------|--|-------------------------------|
| Shaped cap for C track 22x13 | 1 | Cap to be inserted between the locking profile and the guide. | Rubber | To be jointed. | To be inserted with silicone. |
| Shaped cap for lower rail | 2 | To guarantee the system tightness. | Rubber | Apply under the profile with silicone on the back. | |
| Rear lower covering cap | 3 | Cap to close the hardware groove on the lower transom, in the sash extremity. | Plastic material | - | 4x30 mm screws. |
| Cap and glider for front upper guide | 4 | Glider for the sash sliding on the concealed guide; the plastic glider is used as covering cap of the upper milling. | Plastic material | Place in the slot between sash and frame. | 4x30 mm screws. |
| Cap and glider for rear upper guide | 5 | | | | |
| 2 mm adapter for fixed sash | 6 | Adapter for the fixed sash fastening. | Plastic material | - | To be inserted. |

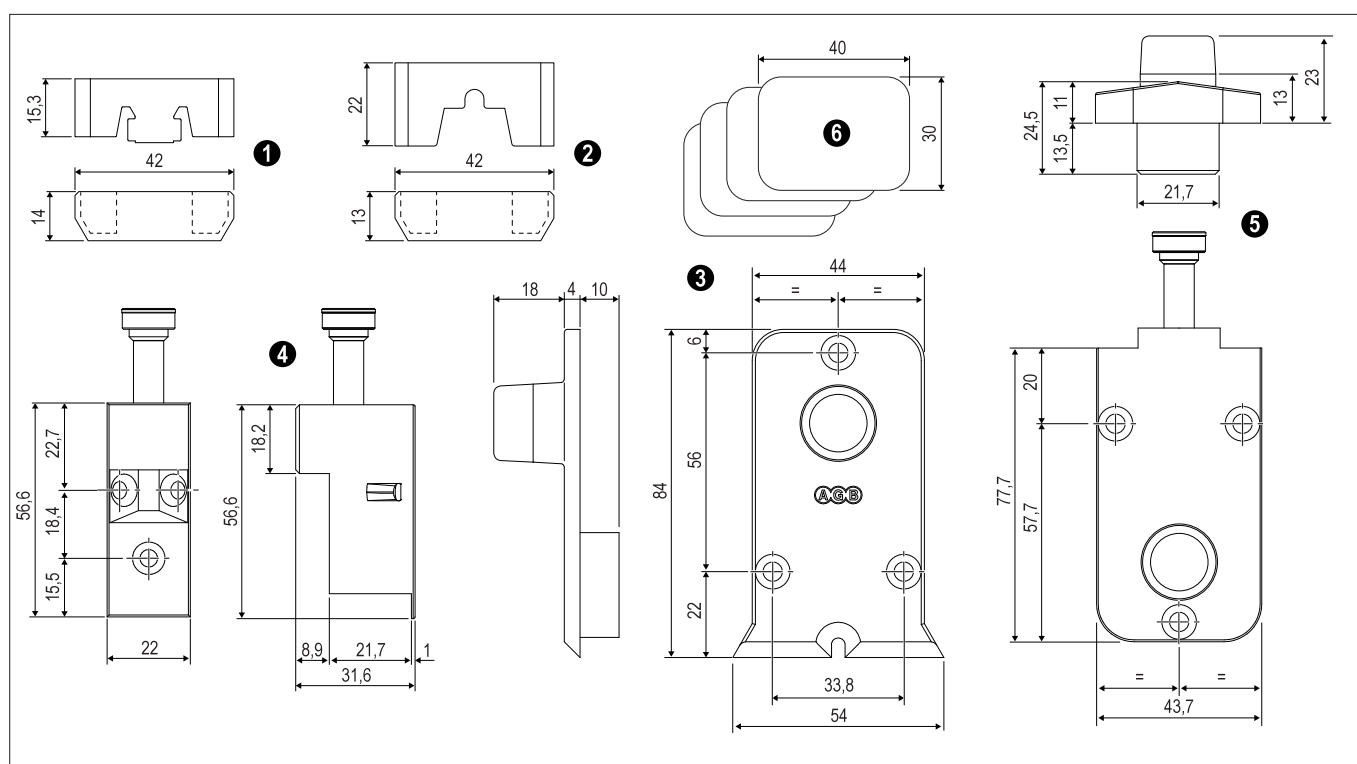

Caps kit for embedded upper guide 22x13 - low rail

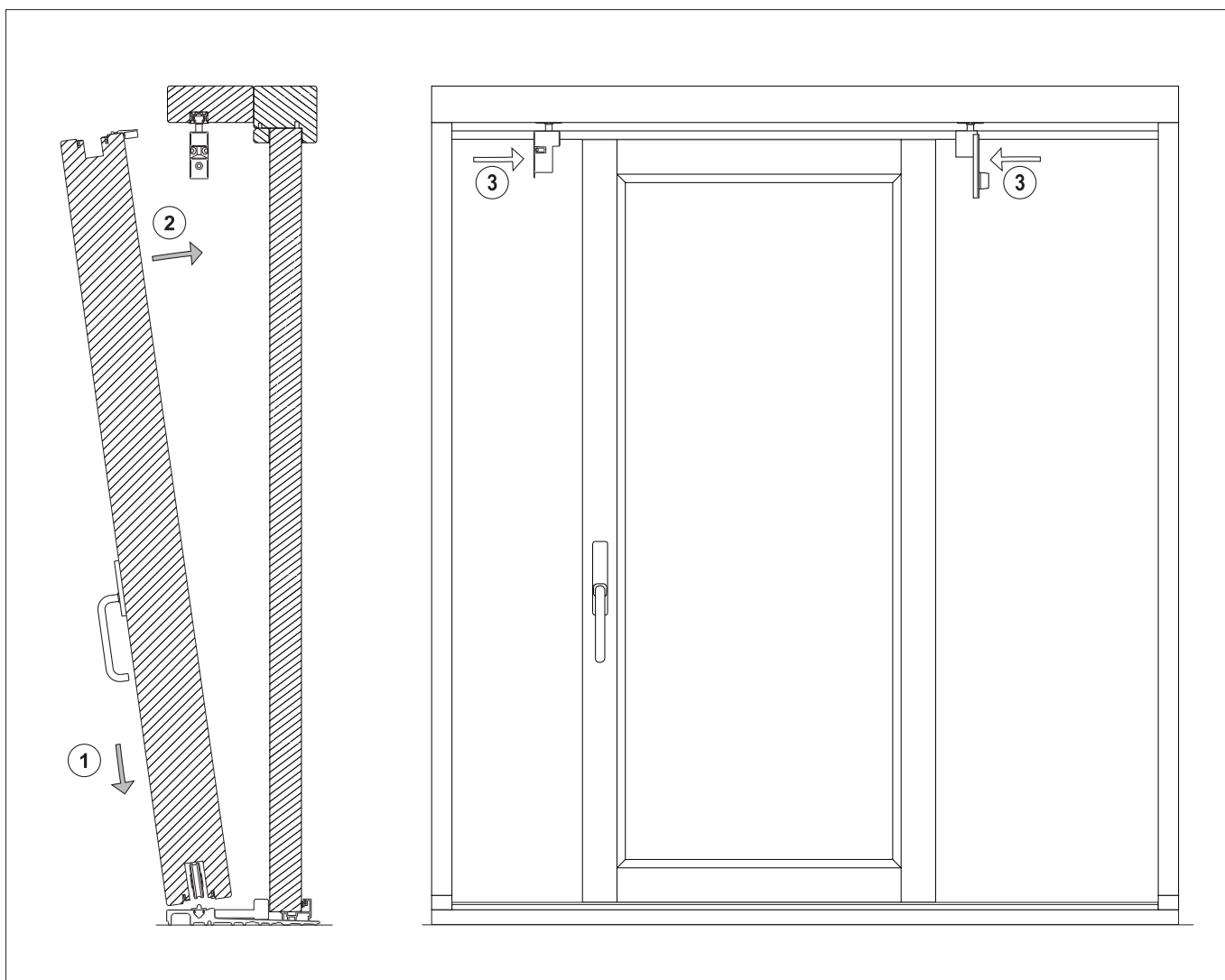

- ① Place the sash on the rail with the carriages in opening position;
- ② Place the sash in vertical position;
- ③ Fasten the gliders on the sliding sash.

| Article | Grey RAL 7038 | Black |
|--|---------------|--------------|
| Caps kit for embedded upper guide 22x13 (Imago) - Low rail | G00223.01.86 | G00223.01.93 |

330 kg carriages kit, 440 kg supplementary carriages kit, carriages connecting rod

| Article | Ref. | Description | Material | Use | Fastening |
|---|------|---|------------------|---|------------------|
| Carriages kit, 300 kg | 1 | Two carriages (front and rear, non-handed) with lift device and lever and rings. The connection between the two carriages is provided by the through cuttable rod. The hooking of the connecting rod is guaranteed by locking grubs with milled base to avoid possible loosening. | Steel | Sliding sashes of weight ≤ 330 Kg | Screws 4,5x35 mm |
| Carriages kit, 300 kg with adjustable rear carriage | 2 | Standard front carriage; rear carriage with +3,5 mm in height. | | | |
| Supplementary carriages kit | 3 | Two carriages with lift device. Each carriage has to be coupled to a carriage of the 330 kg kit (front and rear) through connecting rod and locking grubs. | Steel | Sliding sashes of weight ≥ 330 Kg and ≤ 440 kg | Screws 4,5x35 mm |
| Carriages connecting rod | 4 | It ensures the connection between a carriage and the other and transfers the movement of opening/closing. | Steel | Cuttable 1 piece | Grubs provided |
| Bumper / support | 5 | It allows to download the carriage weight from the sash to the snap-in rail; suitable for aluminium systems where the sash weight in closing position can't be downloaded to the gaskets. | Plastic material | 1 for each carriage | Snap-in rail |
| Rod guide | 6 | Inserted into the carriage milling, it ensures the correct operation of connecting rod. | Plastic material | 1 for each sliding sash | Screws 4x30 mm |
| Anti-derailed adapter | 7 | Dedicated zamak adapter that prevents the derailing movement of sliding sash carriages after forces which are orthogonal to the sliding axis (e.j. weather conditions). | Zamak | Install 2 devices on each central sash; install 1 block on each side sash | Screws 4x30 mm |

Note. Level the glass in order to download the weight evenly in correspondance to the carriages.

Note. Please don't distribute the supplementary carriages along the sash but install them coupling the main carriages.

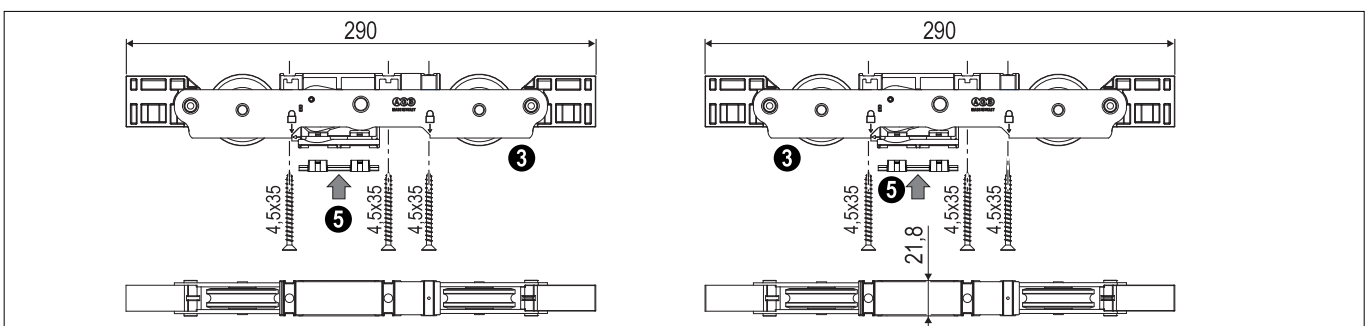
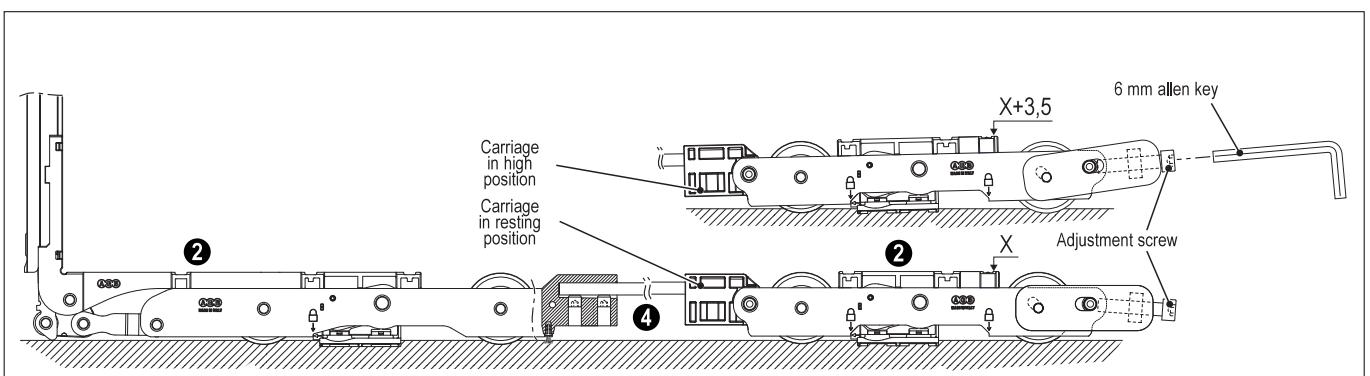
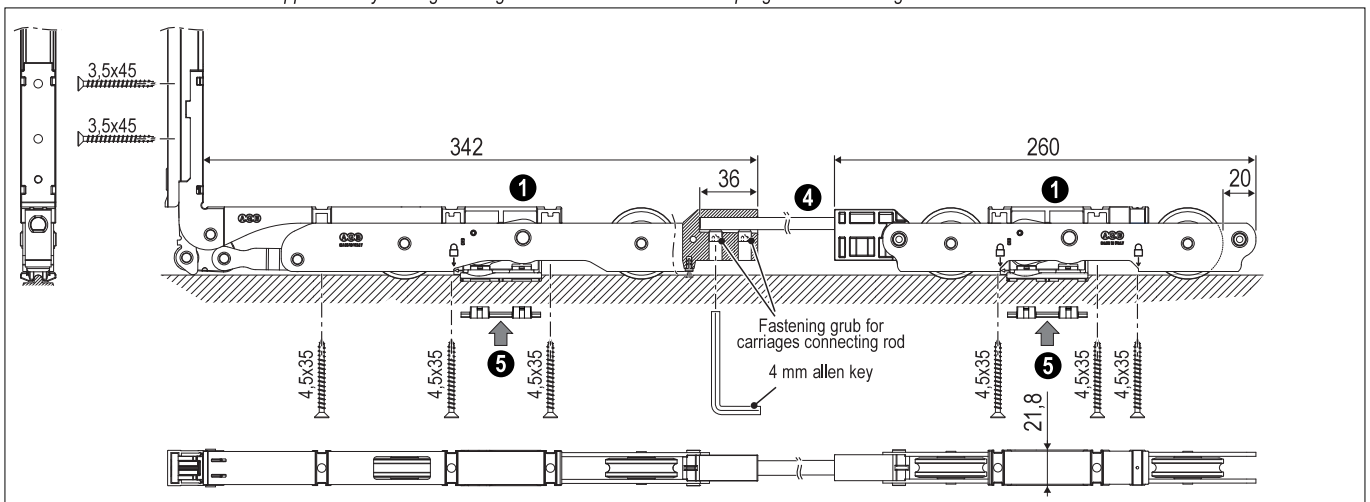

330 kg carriages kit, 440 kg supplementary carriages kit, carriages connecting rod

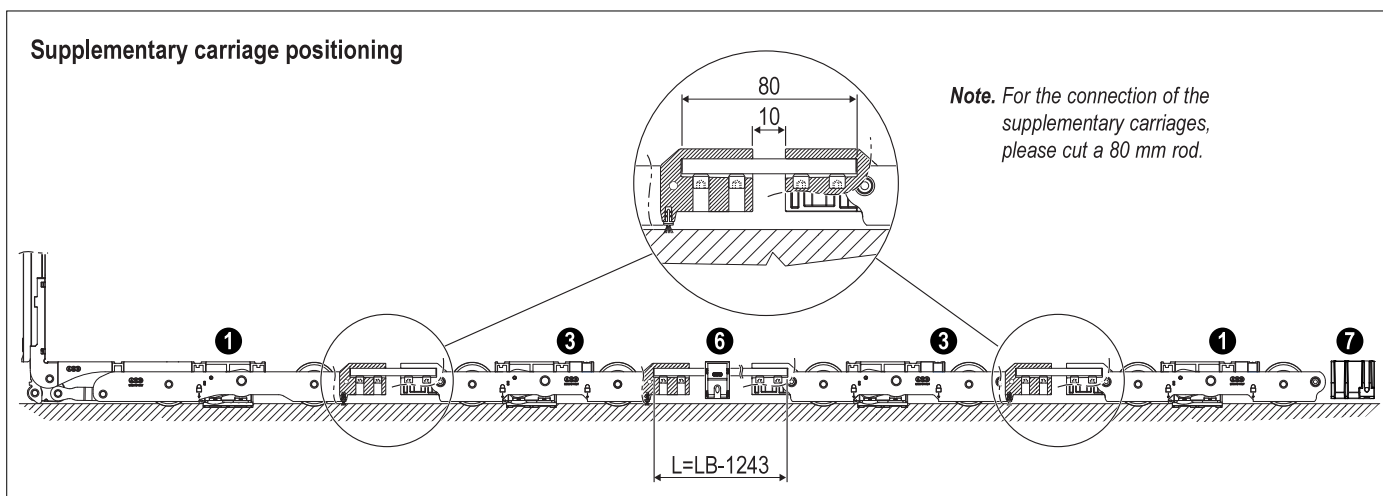
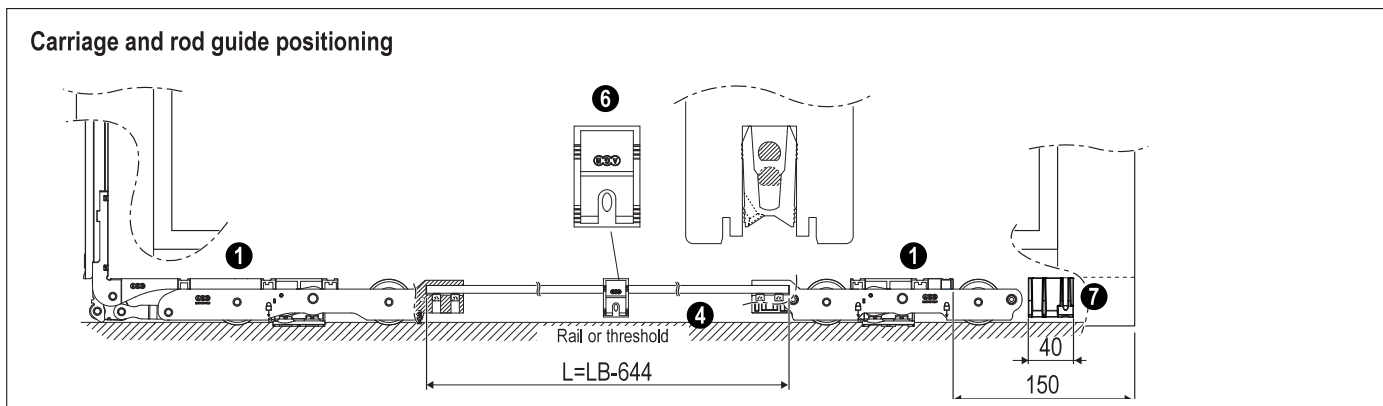
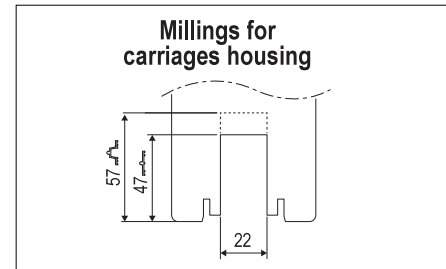
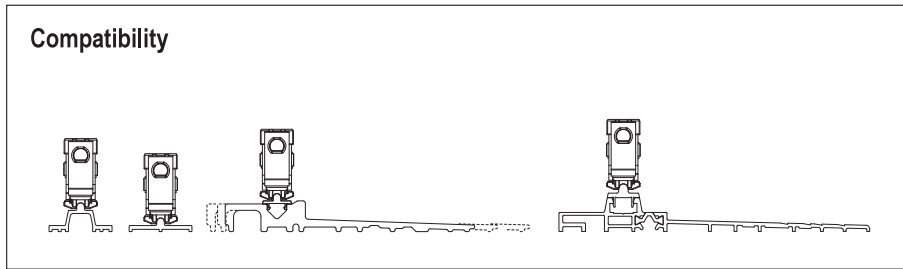

| Application fields | | | | |
|--------------------------|---------|---------|---------------------------------------|---------|
| Carriages connecting rod | 330 Kg | | 440 Kg (with supplementary carriages) | |
| | Min. SW | Max. SW | Min. SW | Max. SW |
| 1000 | 645 | 1644 | 1245 | 2083 |
| 1400 | | 2044 | | 2483 |
| 1800 | | 2444 | | 2883 |
| 2700 | | 3344 | | 3783 |

| Ref. | Description | Code | Length |
|------|--|--------------|--------|
| 1 | Carriages kit, 330 kg | G04104.00.00 | - |
| 2 | Carriages kit, 330 kg, with adjustable rear carriage | G04114.00.00 | - |
| 3 | Supplementary carriages kit (440 kg) | G04108.00.00 | - |
| 4 | Carriage connecting rod | G04601.00.01 | 1000 |
| | | G04601.00.02 | 1400 |
| | | G04601.00.03 | 1800 |
| | | G04601.00.04 | 2700 |

| Ref. | Description | Code |
|------|----------------------|--------------|
| 5 | Bumper - support | G01437.00.86 |
| 6 | Rod guide | G05102.00.00 |
| 7 | Anti-derailed device | G01611.02.00 |

250 kg XC S-Line carriages kit, 400 kg XC S-Line supplementary carriages kit, XC carriages connecting rod

| Article | Ref. | Description | Material | Use | Fastening |
|--|------|--|------------------|---|------------------|
| Carriages kit, XC S-Line 250 Kg | ① | Two carriages (front and rear, non-handed) with lift device and lever and rings. The connection between the two carriages is provided by the through cuttable rod. The hooking of the connecting rod is guaranteed by locking grubbs with milled base to avoid possible loosening. | Steel | Sash weight ≤ 250 Kg | Screws 4,5x35 mm |
| | ② | The adapters allow the carriages assembly on 18 and 22 mm millings. | Plastic material | Use to install the carriages on 18 and 22 mm millings | Clip |
| Supplementary carriages kit XC S-Line 400 kg | ③ | Two carriages with lever lifting device and guides. Each carriage has to be coupled with one of the XC S-Line carriages kit (front and rear) by connecting rod and fastening grubbs. | Steel | Sash weight > 250 Kg and ≤ 400 kg | Screws 4,5x35 mm |
| Connecting rod | ④ | It ensures the connection between a carriage and the other and transfers the movement of opening/closing. | Steel | Cut 1 piece | Grubs provided |
| Stop / support | ⑤ | It allows to download the carriage weight from the sash to the snap-in rail; suitable for aluminium systems where the sash weight in closing position can't be downloaded to the gaskets. | Plastic material | 1 for each carriage | Snap-in rail |
| Rod guide | ⑥ | Inserted into the carriage milling, it ensures the correct operation of connecting rod. | Plastic material | 1 for each sliding sash. Do not use on 16 mm width milling. | Screws 4x30 mm |
| Anti-derailed adapter | ⑦ | Dedicated zamak device that prevents the carriages derailment of the sliding sash after orthogonal pushes on the sliding axis (for example weather agents). | Zamak | Install 2 blocks on each central sash; install 1 block on each side sash. Do not use on 16 mm width milling. | Screws 4x30 mm |

Note. Level the glass in order to download the weight evenly in correspondence to the carriages.

Note. Please don't distribute the supplementary carriages along the sash but install them coupling the main carriages.

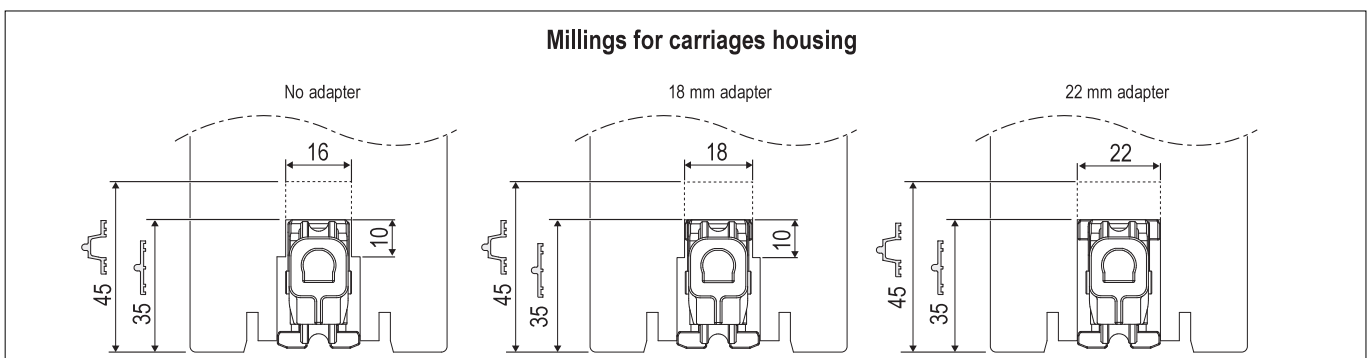
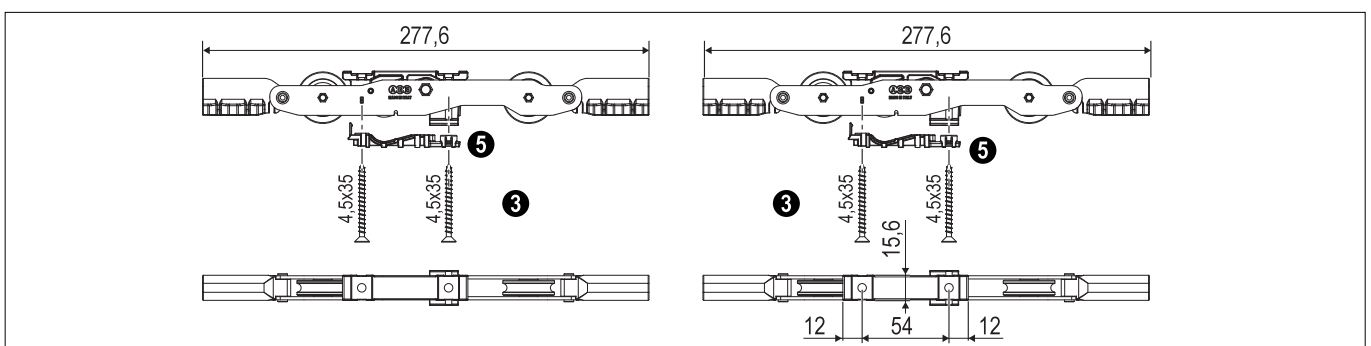
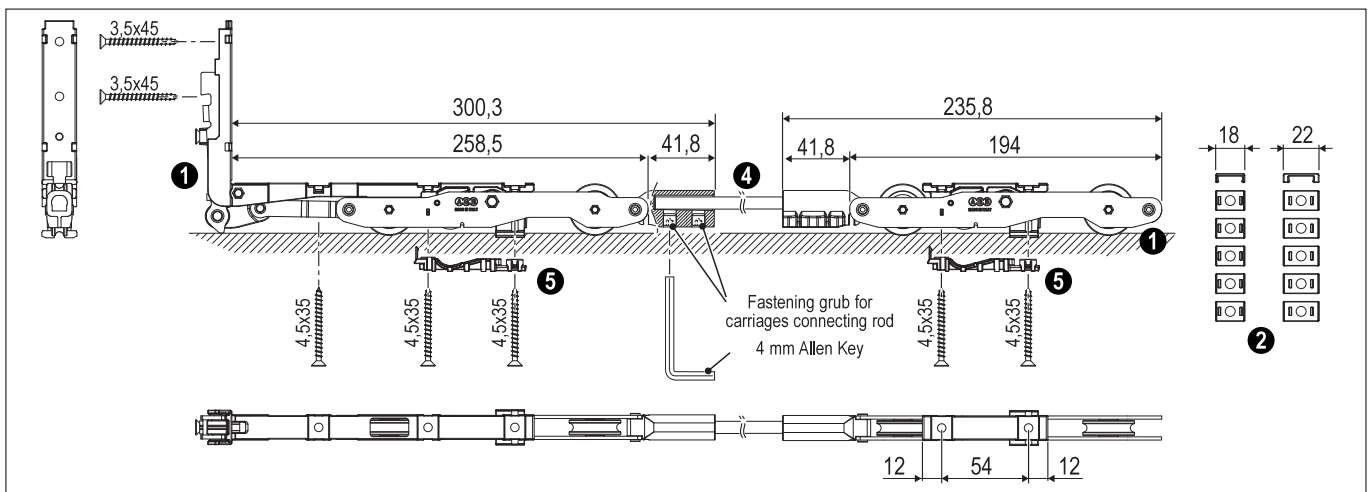

250 kg XC S-Line carriages kit, 400 kg XC S-Line supplementary carriages kit, XC carriages connecting rod

Compatibility

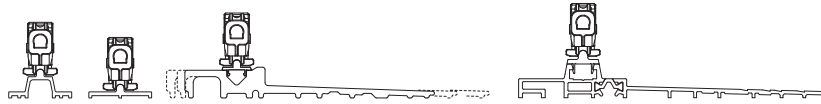

Carriage and rod guide positioning

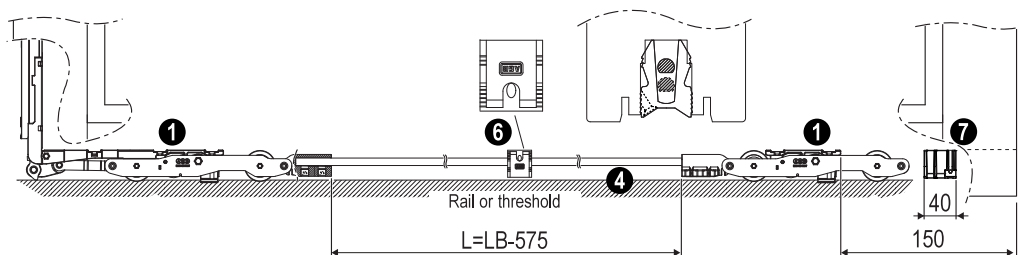

Supplementary carriage positioning

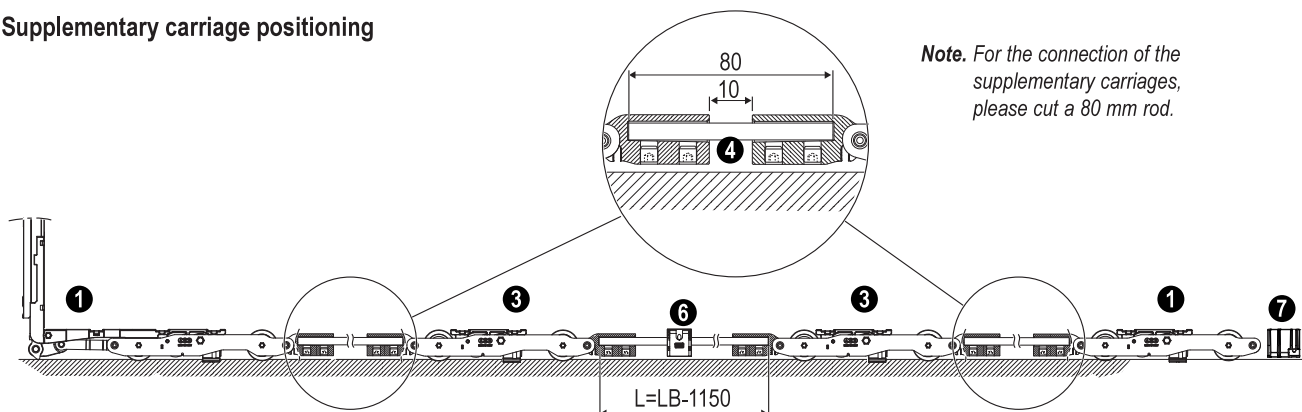

Application fields

| Length of connecting rod | 250 Kg | | 400 Kg (with supplementary carriages) | |
|--------------------------|---------|---------|--|---------|
| | Min. SW | Max. SW | Min. SW | Max. SW |
| 1000 | 580 | 1575 | 1160 | 1990 |
| 1400 | | 1975 | | 2390 |
| 1800 | | 2375 | | 2790 |
| 2700 | | 3275 | | 3690 |

| Ref. | Description | Code | Length |
|------|------------------------------------|--------------|--------|
| 1 | 250 kg carriages kit | G04109.00.00 | - |
| 3 | 400 kg supplementary carriages kit | G04110.00.00 | - |
| 4 | Carriage connecting rod | G04601.00.01 | 1000 |
| | | G04601.00.02 | 1400 |
| | | G04601.00.03 | 1800 |
| | | G04601.00.04 | 2700 |

| Ref. | Description | Code | Length |
|------|----------------------|--------------|--------|
| 5 | Bumper - support | G02142.00.XX | - |
| 6 | Rod guide | G05104.00.00 | - |
| 7 | Anti-derailed device | G01611.01.00 | - |

Locking profiles for lateral point and extension

| Article | Description | Material | Use | Fastening |
|---------|--|-----------|---|------------------|
| 1 | Pre-drilled locking profile (2 suitable seats) | Aluminium | On lateral point of lift&slide systems, coupled to the lock | Screws 4,5x45 mm |
| 2 | Pre-drilled locking profile (3 suitable seats) Note. Not suitable for striker with signal system. | | | |
| 3 | Pre-drilled locking profile (3 suitable seats, the one in the middle for striker with signal system) Note. The central housing is suitable for striker with signal system. | | | |
| 4 | Locking profile extension Installed above the locking profile, it allows the extension of the application field and the addition of a locking point. | | | |

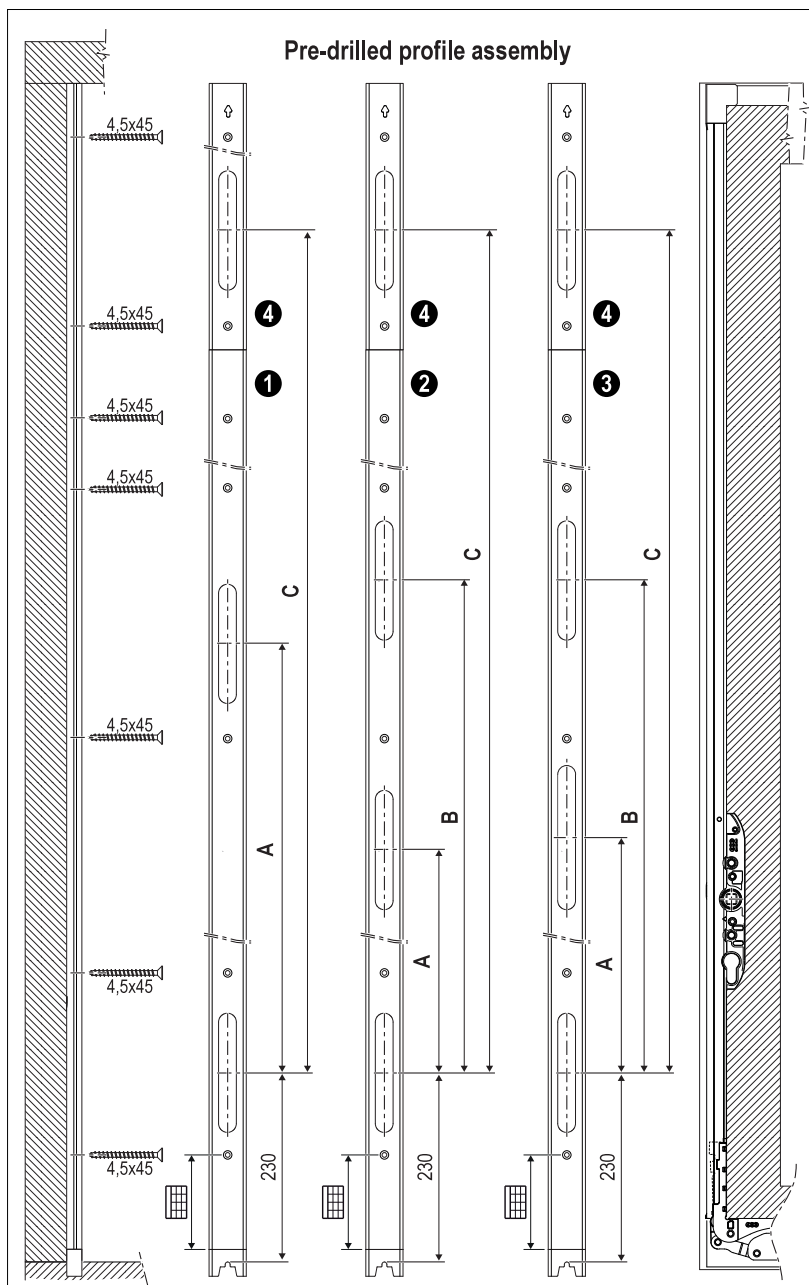
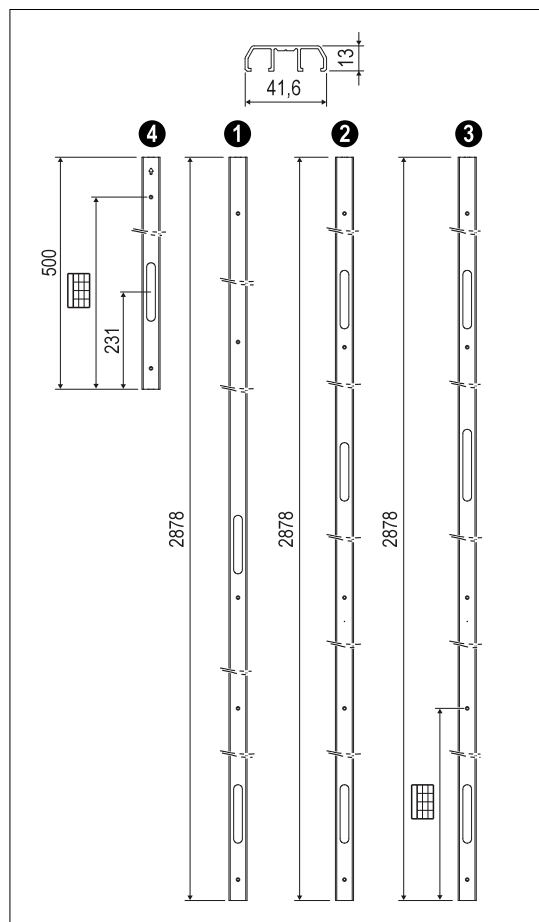

| Locking points position | | | | | |
|-------------------------|----|------------------------|--------|------|---------------|
| | GR | Locking profile height | A | B | C (min - max) |
| 1 | 3 | 2878 | 1354 | - | 1789,5+2137,5 |
| | 4 | 2878 | 1504 | - | 1939,5+2387,5 |
| | 5 | 2878 | 1904 | - | 2339,5+2737,5 |
| 2 | 3 | 2878 | 970 | 1354 | 1789,5+2137,5 |
| | 4 | 2878 | 970 | 1504 | 1939,5+2387,5 |
| | 5 | 2878 | 970 | 1904 | 2339,5+2737,5 |
| 3 | 3 | 2878 | 1042,6 | 1354 | 1789,5+2137,5 |
| | 4 | 2878 | 1042,6 | 1504 | 1939,5+2387,5 |
| | 5 | 2878 | 1042,6 | 1904 | 2339,5+2737,5 |

| Article | GR | Article code, in Silver | Article code, in Electrocolour | Length | SH | Suitable seats for striker |
|---------|----|-------------------------|--------------------------------|--------|-----------|----------------------------|
| 1 | 3 | G01359.03.01 | G01359.03.02 | 2878 | 1770-2900 | 2 |
| | 4 | G01359.04.01 | G01359.04.02 | | | |
| | 5 | G01359.05.01 | G01359.05.02 | | | |
| 2 | 3 | G01359.13.01 | G01359.13.02 | 2878 | 1770-2900 | 3 |
| | 4 | G01359.14.01 | G01359.14.02 | | | |
| | 5 | G01359.15.01 | G01359.15.02 | | | |
| 3 | 3 | G01359.23.01 | G01359.23.02 | 2878 | 1770-2900 | 2+1 |
| | 4 | G01359.24.01 | G01359.24.02 | | | |
| | 5 | G01359.25.01 | G01359.25.02 | | | |
| 4 | - | G01360.01.01 | G01360.01.02 | 500 | 2900+500 | 1 |

| Screw holes position | | | | | | |
|----------------------|----|-----|-----|------|------|------|
| | GR | 1° | 2° | 3° | 4° | 5° |
| 1 | 3 | 48 | 748 | 1448 | 2148 | 2718 |
| 2 | 4 | 48 | 748 | 1448 | 2148 | 2718 |
| 3 | 5 | 48 | 748 | 1448 | 2018 | 2718 |
| 4 | - | 128 | 338 | - | - | - |

Pin holder profile for lateral point

| Article | Description | Material | Use | Fastening |
|-----------------------------|---|-----------|--|------------------|
| Pre-drilled locking profile | Pin holder profile in anodised aluminium with suitable holes for pins housing. Caps for unused holes. | Aluminium | Lateral point of Lift&Slide systems coupled to the lock. | 4,5x45 mm screws |

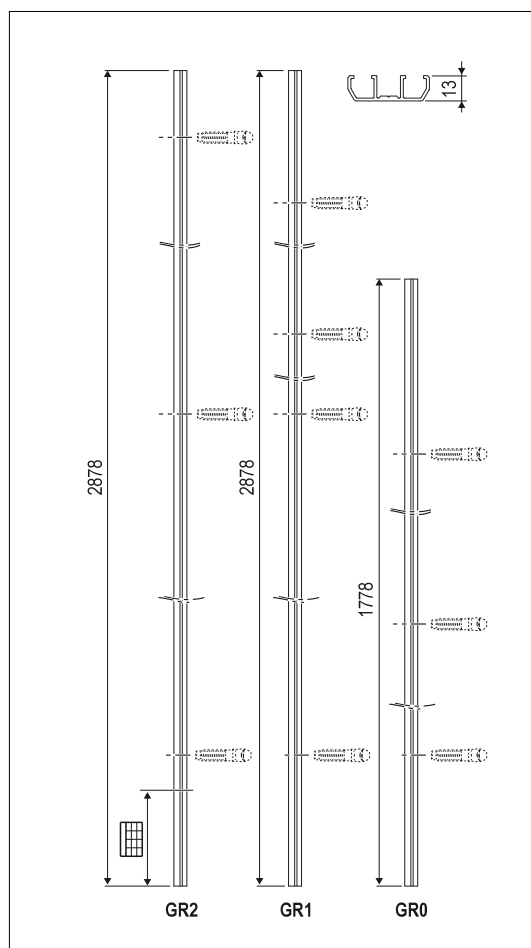

| GR | 1° | 2° | 3° | 4° | 5° |
|----|-----|-----|------|------|------|
| 0 | 48 | 748 | 1448 | | |
| 1 | 48 | 748 | 1448 | 2148 | 2718 |
| 2 | 160 | 730 | 1430 | 2130 | 2830 |

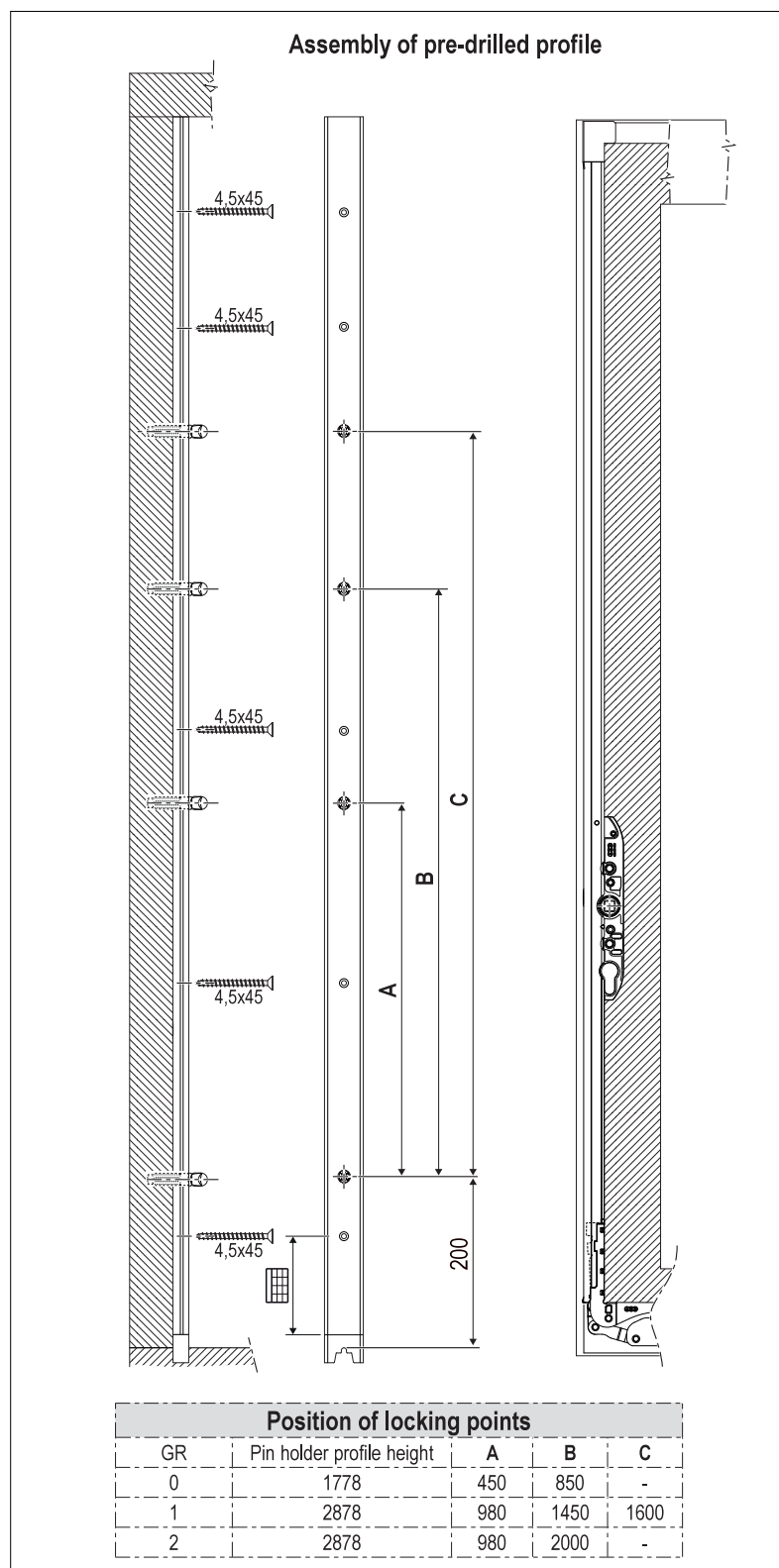

| Article | GR | Article code, in Silver | Article code, in Electrocolour | Length | SH | |
|-----------------------------|----|-------------------------|--------------------------------|--------------|------|-----------|
| Pre-drilled locking profile | 0 | For lock GR1 and GR2 | G01341.00.01 | G01341.00.02 | 1778 | 800-1800 |
| | 1 | For lock GR3 and GR4 | G01341.01.01 | G01341.01.02 | 2878 | 1770-2900 |
| | 2 | For lock GR5 | G01341.02.01 | G01341.02.02 | 2878 | 1770-2900 |

Locking profile pins for coaxial sashes and dedicated extensions

| Article | | Description | Material | Use | Fastening |
|--|---|---|-----------------------------------|---------------------------------|---|
| Locking profile kit for coaxial sashes with end caps | ① | Locking profile with pre-assembled anti-burglar pins. Thanks to specific end caps (lower and upper), it ensures the perfect insulation in critic areas of systems with coaxial sashes (low side and high side of central point). It replaces the wooden clamp with a great time saving for window workings. | Profile: aluminium Pins: steel | On systems with coaxial sashes. | Screws 4,5x60 mm. The position of profile screw holes coincide exactly with lock screw holes which are free. |
| Locking profile extension for coaxial sashes | ② | Extension for locking profile available with or without pin. | | | |

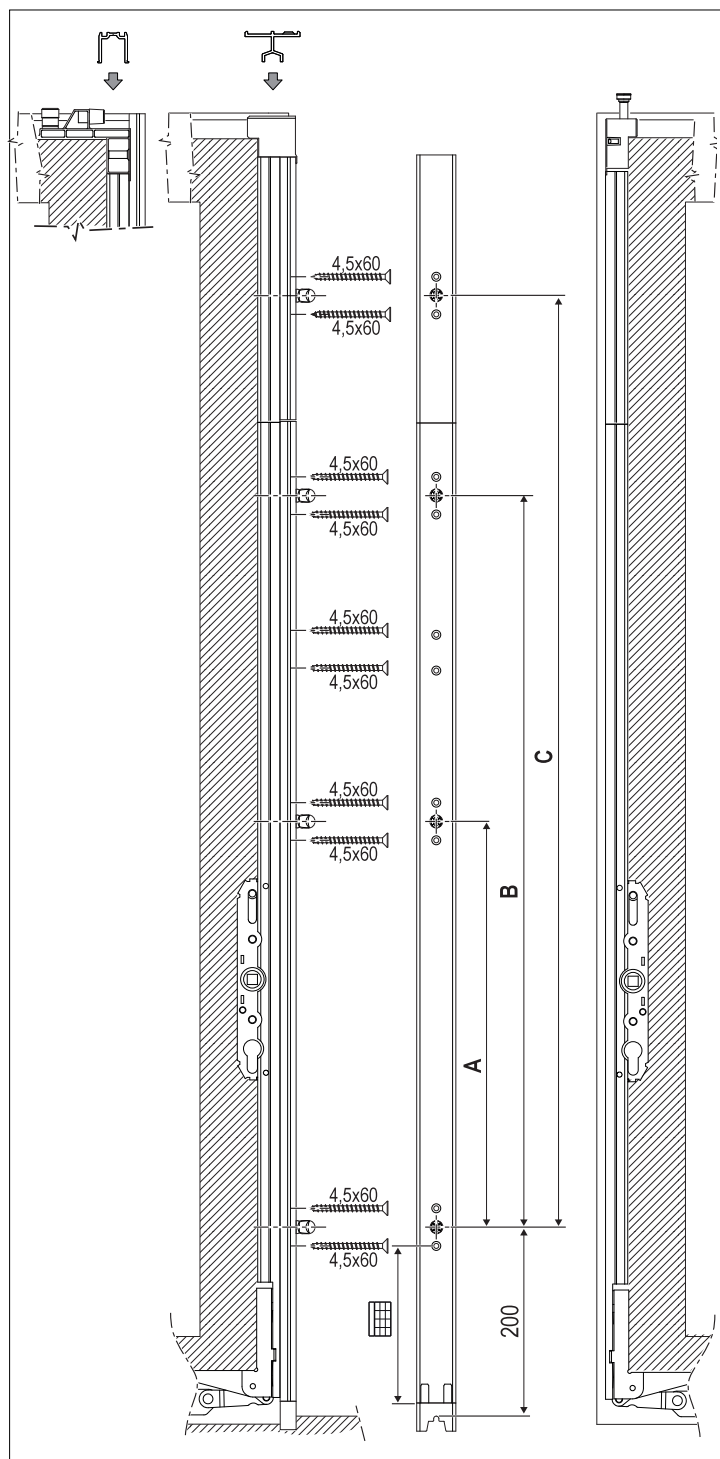
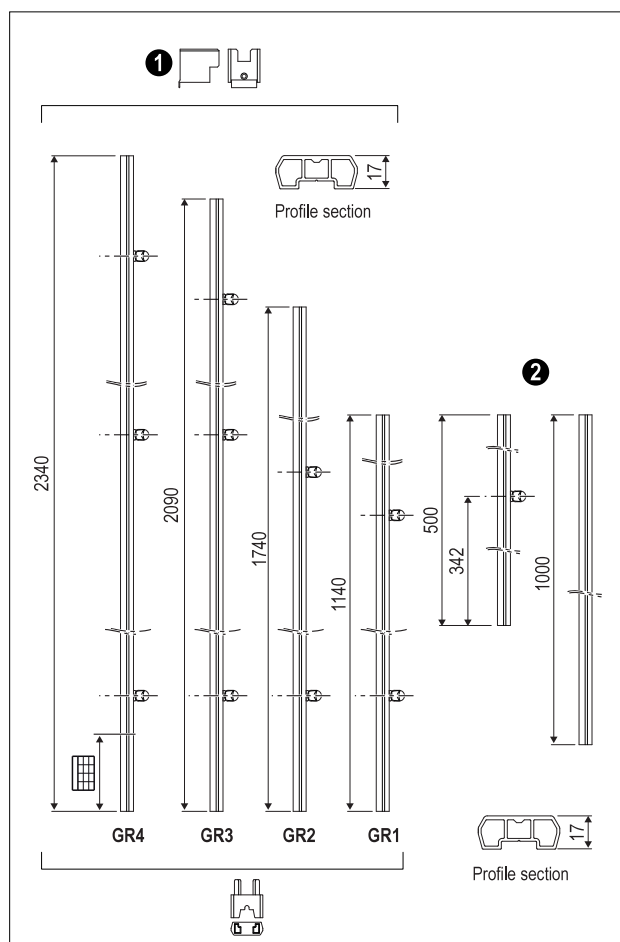

| Screw holes positioning | | | | | | | | |
|-------------------------|-----|-----|-----|-----|------|------|------|------|
| GR | 1° | 2° | 3° | 4° | 5° | 6° | 7° | 8° |
| 1 | 132 | 232 | 294 | 512 | 582 | 682 | | |
| 2 | 132 | 232 | 294 | 512 | 982 | 1082 | | |
| 3 | 132 | 232 | 832 | 894 | 1112 | 1212 | 1582 | 1682 |
| 4 | 132 | 232 | 832 | 894 | 1112 | 1212 | 1732 | 1832 |

| Position of locking points | | | | |
|----------------------------|---------------------------|-----|------|---------------|
| GR | Pin holder profile height | A | B | C * |
| 1 | 1140 | 450 | - | 783,5-1283,5 |
| 2 | 1740 | 850 | - | 1183,5-1883,5 |
| 3 | 2090 | 980 | 1450 | 1783,5-2233,5 |
| 4 | 2340 | 980 | 1600 | 1933,5-2483,5 |

* Achievable only with 500 mm extension

| | Article | GR | Article code, in Silver | Article code, in Electrocolour | SRH | Handle height | Lock height |
|---|--|----|-------------------------|--------------------------------|-----------|---------------|-------------|
| ① | Locking profile kit for coaxial sashes with end caps | 1 | G01757.01.01 | G01757.01.02 | 810-1200 | 400/410 | 1124 |
| | | 2 | G01757.02.01 | G01757.02.02 | 1170-1800 | 400/410 | 1724 |
| | | 3 | G01757.03.01 | G01757.03.02 | 1770-2150 | 1000/1010 | 2074 |
| | | 4 | G01757.04.01 | G01757.04.02 | 1920-2400 | 1000/1010 | 2324 |

| Ref. | Article | Article code, in Silver | Article code, in Electrocolour | Length |
|------|-----------------------|-------------------------|--------------------------------|--------|
| ② | Extension with pin | G01757.97.01 | G01757.97.02 | 500 |
| | Extension without pin | G01757.00.01 | G01757.00.02 | 1000 |

Gas spring kit and sensors

| Article | Ref. | Description | Use | Fastening |
|----------------|------|---|--|---|
| Gas spring kit | ❶ | Gas cylinder that helps the sash opening movement (lifting) and reduce the speed of the handle. | Apply in suitable holes into the movable rod and in the aluminium profile of the lock. Please use with sashes of weight ≥ 200 Kg. | Screws are provided. Note. Please assemble the gas spring with lock in opening position and lying spring. |
| Sensors | ❷ | Magnet and sensor for the control of opening. | Apply the magnet in the suitable hole of the movable rod and the sensor in the hole to realise the pin holder profile. | To joint |
| Magnet | ❸ | Magnet with clip for lock. | Apply the magnet in the dedicated hole of the movable rod. | With clip |

Gas spring installation

Fasten the carriages and the connecting rod to the carriages.
Unlock the carriages and put them in opening position.
Assemble the lock (with gas spring) in opening position.

❶

❷

❸

Place the kit in specific holes under the handle

Identification of dedicated holes

Assembly order

❶

Installation of reed sensors

Find the point where the sensor and the magnet have to be installed

Please make a hole Ø12 mm (aluminium pin holder profile)

Please make a hole Ø12 mm (wooden pin holder profile)

❷

Reed sensor

❷

Reed sensor

❸

Magnet holder with clip

❸

Magnet holder with clip

1330

| Ref. | Article | Article code |
|------|----------------|--------------|
| ❶ | Gas spring kit | GMG702.04.00 |

| Ref. | Article | Article code | Colour |
|------|--------------|--------------|--------|
| ❷ | Sensor + cap | G05006.00.86 | Grey |
| | | G05006.00.93 | Black |

| Ref. | Article | Article code |
|------|----------------|--------------|
| ❸ | Magnet on clip | G05003.00.00 |

440 Kg locks and specific extensions

| Article | Ref. | Description | Material | Use | Fastening |
|------------------|----------|--|---------------------------------|---|--|
| Locks, 440 Kg | 1 | 10 mm handle hub with radius corner, hole for European cylinder housing. | Forend: aluminium Rod: steel | Choose the lock according to the jamb width and the sliding sash height. Backsets available: 27,5 and 37,5 mm in 5 different heights (see the table). | 4,5x45 mm screws ★ For Imago+ use 4,5x40 mm |
| Lock extension | 2 | - | Forend: aluminium Rod: steel | It gives the possibility to add a locking point. | 4,5x45 mm screws ★ For Imago+ use 4,5x40 mm |
| Covering profile | 3 | - | Aluminium | It covers the milling. | 4,5x45 mm screws ★ For Imago+ use 4,5x40 mm |

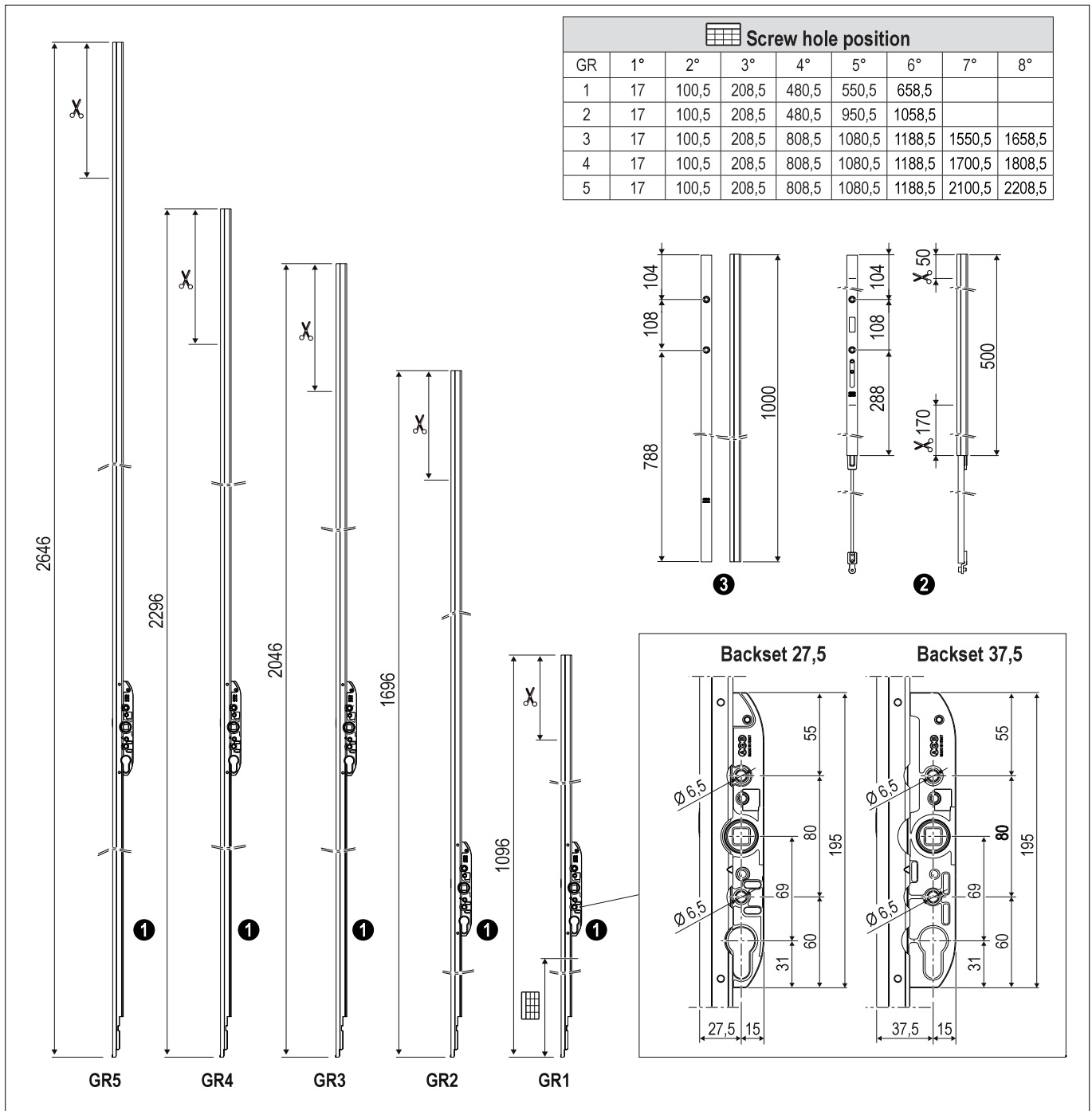

440 Kg locks and specific extensions

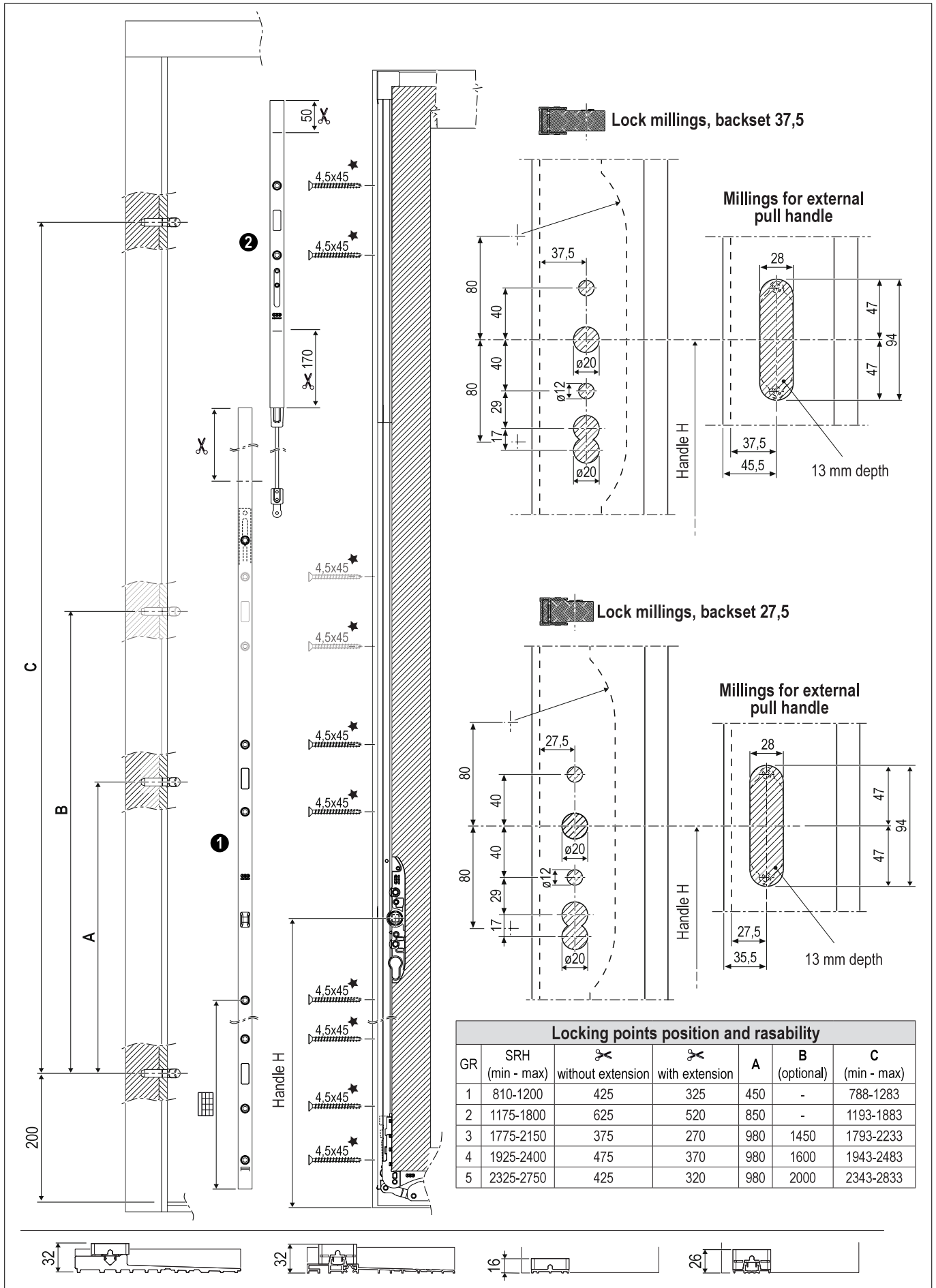

440 Kg locks and specific extensions

| Ref. | Article | GR | Article code, in Silver | Article code, in Electrocolour | SRH ◊ | Handle height | Lock height |
|------|-----------------------------|----|----------------------------|-----------------------------------|-----------|---------------|-------------|
| ❶ | Lock 440 Kg Backset 27,5 | 1 | G04027.01.01 | G04027.01.02 | 810-1200 | 400/410 | 1096 |
| | | 2 | G04027.02.01 | G04027.02.02 | 1175-1800 | 400/410 | 1696 |
| | | 3 | G04027.03.01 | G04027.03.02 | 1775-2150 | 1000/1010 | 2046 |
| | | 4 | G04027.04.01 | G04027.04.02 | 1925-2400 | 1000/1010 | 2296 |
| | | 5 | G04027.05.01 | G04027.05.02 | 2325-2750 | 1000/1010 | 2646 |
| | Lock 440 Kg Backset 37,5 | 1 | G04037.01.01 | G04037.01.02 | 810-1200 | 400/410 | 1096 |
| | | 2 | G04037.02.01 | G04037.02.02 | 1175-1800 | 400/410 | 1696 |
| | | 3 | G04037.03.01 | G04037.03.02 | 1775-2150 | 1000/1010 | 2046 |
| | | 4 | G04037.04.01 | G04037.04.02 | 1925-2400 | 1000/1010 | 2296 |
| | | 5 | G04037.05.01 | G04037.05.02 | 2325-2750 | 1000/1010 | 2646 |

◊ With upper guide 22x22 cod. G01002.XX.XX, the SRH application field will be reduced up to 10 mm.

| Ref. | Article | Article code, in Silver | Article code, in Electrocolour | Length |
|------|------------------------------|----------------------------|-----------------------------------|--------|
| ❷ | Extension with locking point | G04401.01.01 | G04401.01.02 | 500 |
| ❸ | Covering profile | G04401.02.01 | G04401.02.02 | 1000 |

440 Kg hook locks and specific extensions

| Article | Ref. | Description | Material | Use | Fastening |
|------------------|------|--|---|---|--|
| Locks, 440 Kg | ❶ | 10 mm handle hub with radius corner, hole for European cylinder housing. | Forend: aluminium Rod: steel Hooks: steel | Choose the lock according to the jamb width and the sliding sash height. Backsets available: 27,5 and 37,5 mm in 3 different heights (see the table). | 4,5x45 mm screws ★ For Imago+ use 4,5x40 mm |
| Lock extension | ❷ | - | Forend: aluminium Rod: steel Hooks: steel | It gives the possibility to add a locking point. | 4,5x45 mm screws ★ For Imago+ use 4,5x40 mm |
| Covering profile | ❸ | - | Aluminium | It covers the milling. | 4,5x45 mm screws ★ For Imago+ use 4,5x40 mm |

| Screw hole position | | | | | | | | |
|---------------------|----|-------|-------|-------|--------|--------|--------|--------|
| GR | 1° | 2° | 3° | 4° | 5° | 6° | 7° | 8° |
| 3 | 17 | 100,5 | 304,5 | 808,5 | 1080,5 | 1274,5 | 1458,5 | 1658,5 |
| 4 | 17 | 100,5 | 304,5 | 808,5 | 1080,5 | 1274,5 | 1608,5 | 1808,5 |
| 5 | 17 | 100,5 | 304,5 | 808,5 | 1080,5 | 1274,5 | 2008,5 | 2208,5 |

Backset 27,5

Backset 37,5

440 Kg hook locks and specific extensions

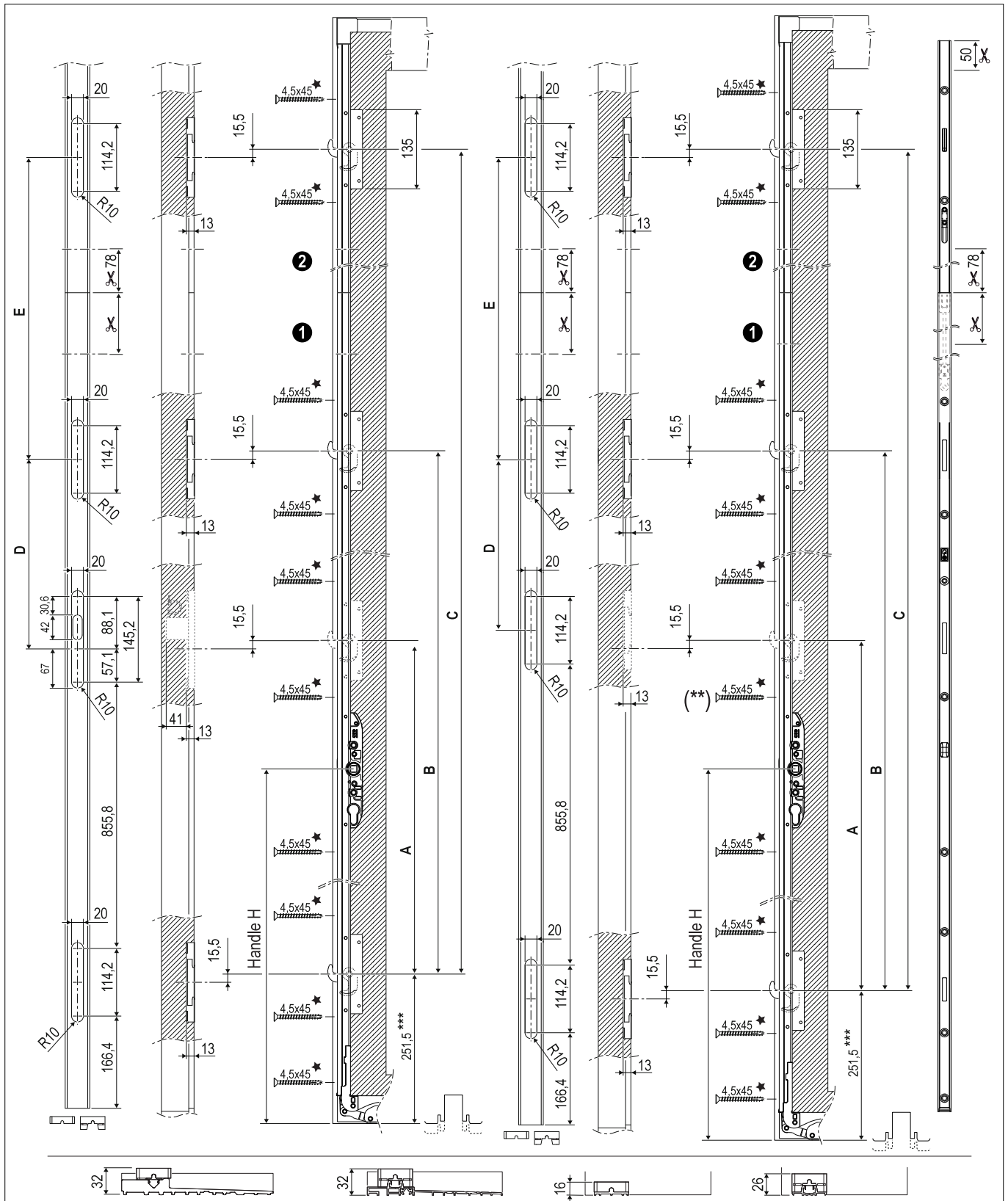

| Locking points position and rasability | | | | | | | | | |
|--|----|--------------------|-------------------|----------------|-----------------|------|------------------|-----|-------|
| | GR | SRH (min - max) | ✂ | | A (optional) | B | C (min - max) | D | E* |
| | | | without extension | with extension | | | | | |
| Without signal system | 3 | 1775-2150 | 375 | 270 | 970 | 1354 | 1789,5+2137,5 | 384 | C - B |
| | 4 | 1925-2400 | 475 | 370 | 970 | 1504 | 1939,5+2387,5 | 534 | C - B |
| | 5 | 2325-2750 | 425 | 320 | 970 | 1904 | 2339,5+2737,5 | 934 | C - B |
| With signal system | 3 | 1775-2150 | 375 | 270 | 970 | 1354 | 1789,5+2137,5 | 384 | C - B |
| | 4 | 1925-2400 | 475 | 370 | 970 | 1504 | 1939,5+2387,5 | 534 | C - B |
| | 5 | 2325-2750 | 425 | 320 | 970 | 1904 | 2339,5+2737,5 | 934 | C - B |

* For rasability check instructions Z90322.14.81

** In case of optional hook use, pre-drill for the screw.

*** In case of a high rail use, the distance is 10 mm higher.

440 Kg hook locks and specific extensions

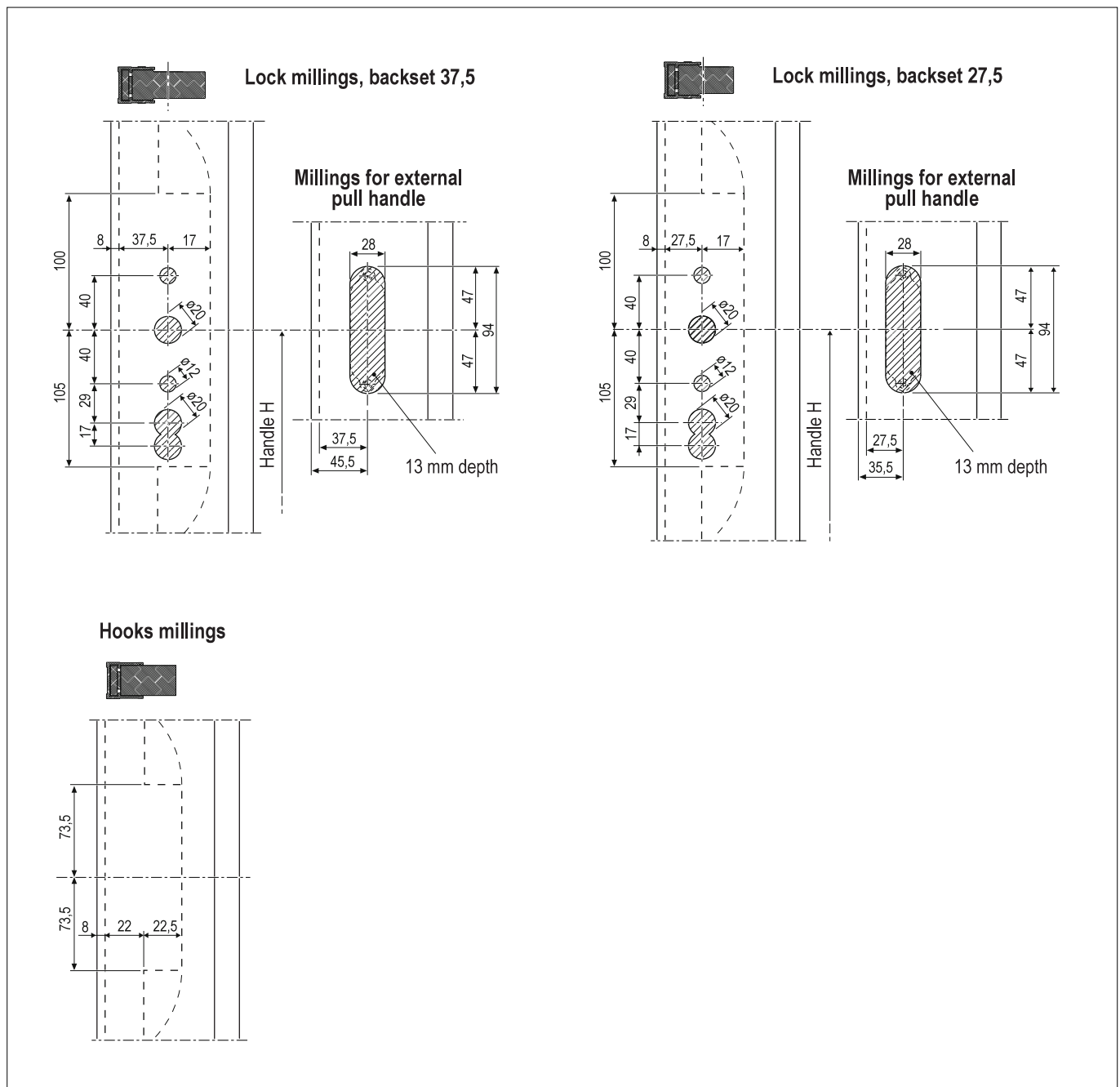

| Ref. | Article | GR | Article code, in Silver | Article code, in Electrocolour | SRH \diamond | Handle height | Lock height |
|------|-----------------------------|----|-------------------------|--------------------------------|----------------|---------------|-------------|
| ❶ | Lock 440 Kg Backset 27,5 | 3 | G03927.03.01 | G03927.03.02 | 1775-2150 | 1000/1010 | 2046 |
| | | 4 | G03927.04.01 | G03927.04.02 | 1925-2400 | 1000/1010 | 2296 |
| | | 5 | G03927.05.01 | G03927.05.02 | 2325-2750 | 1000/1010 | 2646 |
| | Lock 440 Kg Backset 37,5 | 3 | G03937.03.01 | G03937.03.02 | 1775-2150 | 1000/1010 | 2046 |
| | | 4 | G03937.04.01 | G03937.04.02 | 1925-2400 | 1000/1010 | 2296 |
| | | 5 | G03937.05.01 | G03937.05.02 | 2325-2750 | 1000/1010 | 2646 |

\diamond With upper guide 22x22 cod. G01002.XX.XX, the SRH application field will be reduced up to 10 mm.

| Ref. | Article | Article code, in Silver | Article code, in Electrocolour | Length |
|------|------------------------------|-------------------------|--------------------------------|--------|
| ❷ | Extension with locking point | G04600.01.01 | G04600.01.02 | 500 |
| ❸ | Covering profile | G04401.02.01 | G04401.02.02 | 1000 |

Hooks

| Article | Ref. | Description | Material | Use | Fastening |
|--|------|--|-----------------|---|--|
| Additional hook | ❶ | Element with steel hook that can be placed to the lock in the defined position. | Steel and zamak | To add a locking point to the lock | Using the elastic plug supplied, on suitable holes to the lock |
| Additional hook with microventilation position | ❷ | Element with steel microventilation hook that can be placed to the lock in the defined position. | | It ensures the microventilation allowing to pull close the sash to the frame and blocking it in that position | |

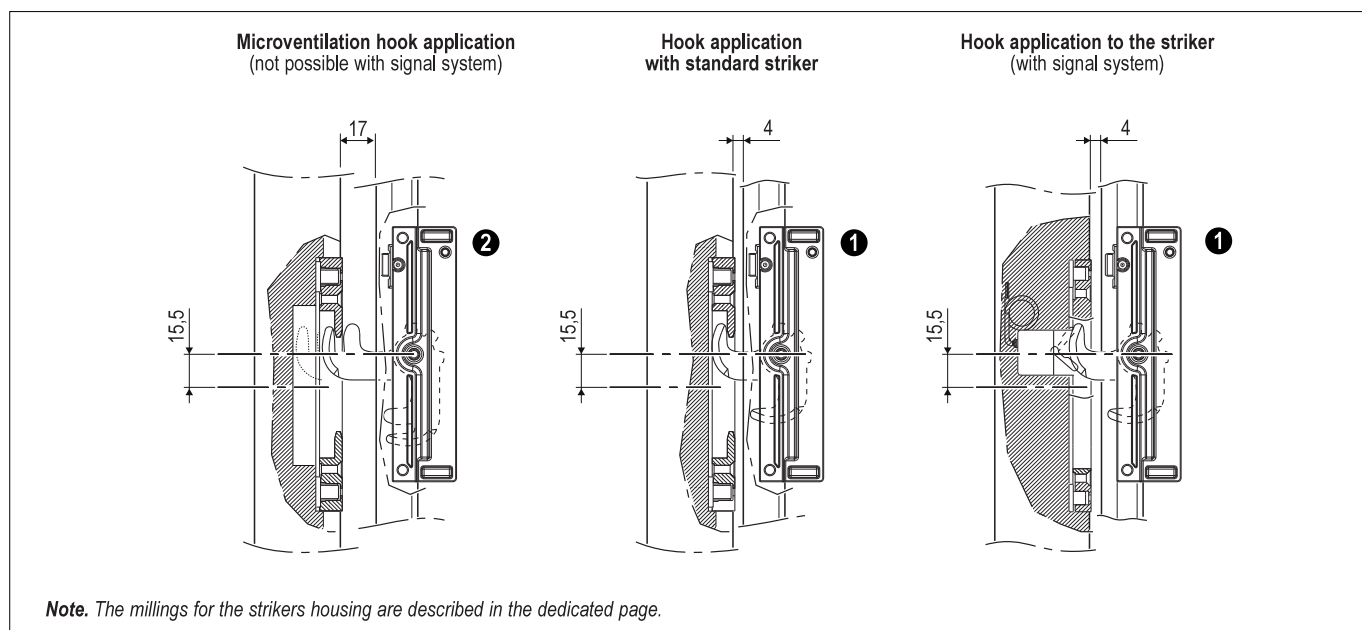
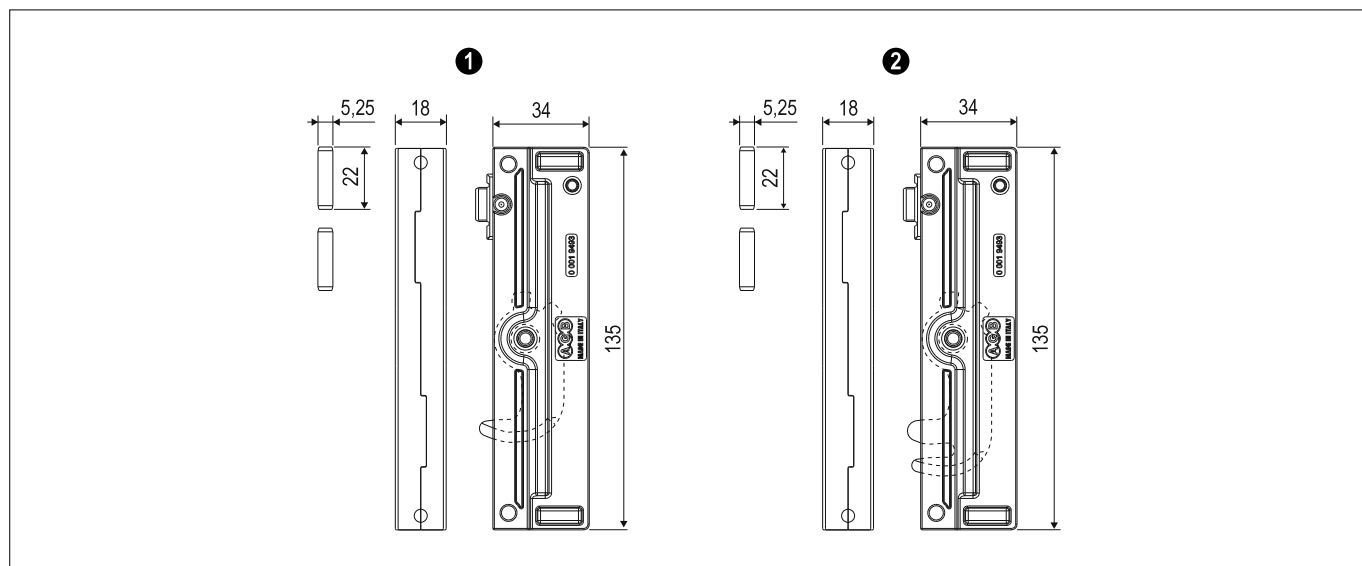

| Ref. | Description | Article |
|------|--|--------------|
| ❶ | Additional hook | G05008.00.00 |
| ❷ | Additional hook with microventilation position | G05010.00.00 |

Strikers

| Article | Ref. | Description | Material | Use | Fastening |
|-------------------------------------|------|---|----------|--|------------------|
| Striker for hook | ❶ | Adjustable locking point | Zamak | - | Screws 4,5x45 mm |
| Striker for hook with signal system | ❷ | Adjustable locking point with control device of hook position | Zamak | Connected to a control device, it allows to find the hook position. Note. It can't be applied to coaxial sashes profile. Note. It isn't compatible with microventilation hook. | Screws 4,5x45 mm |

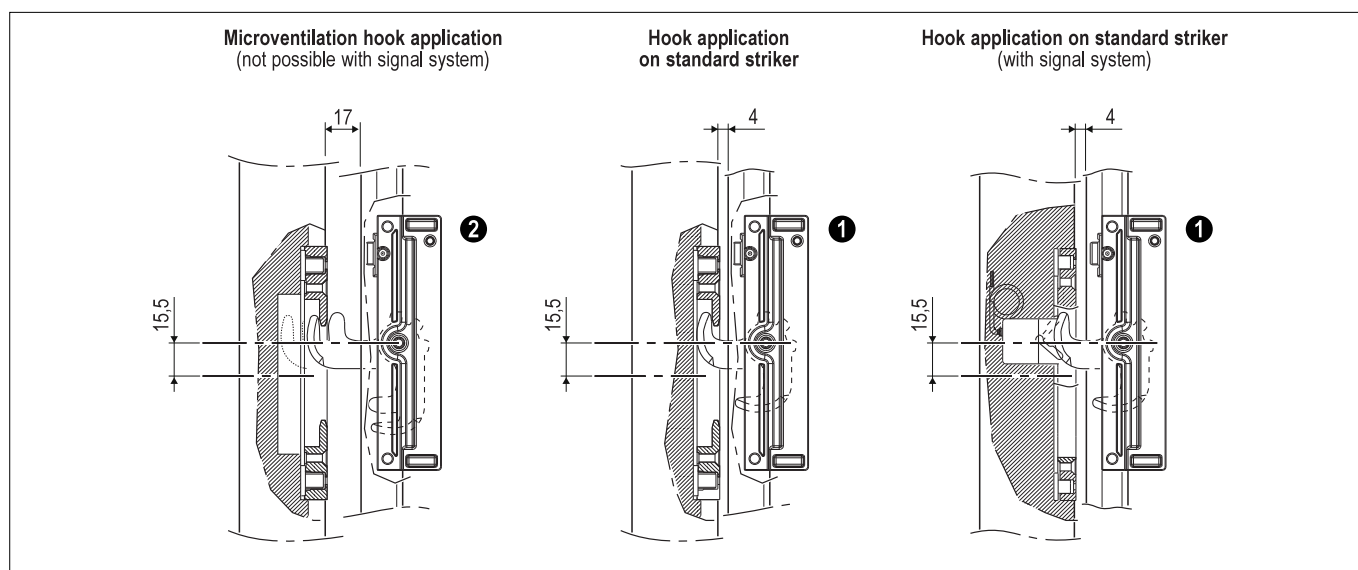
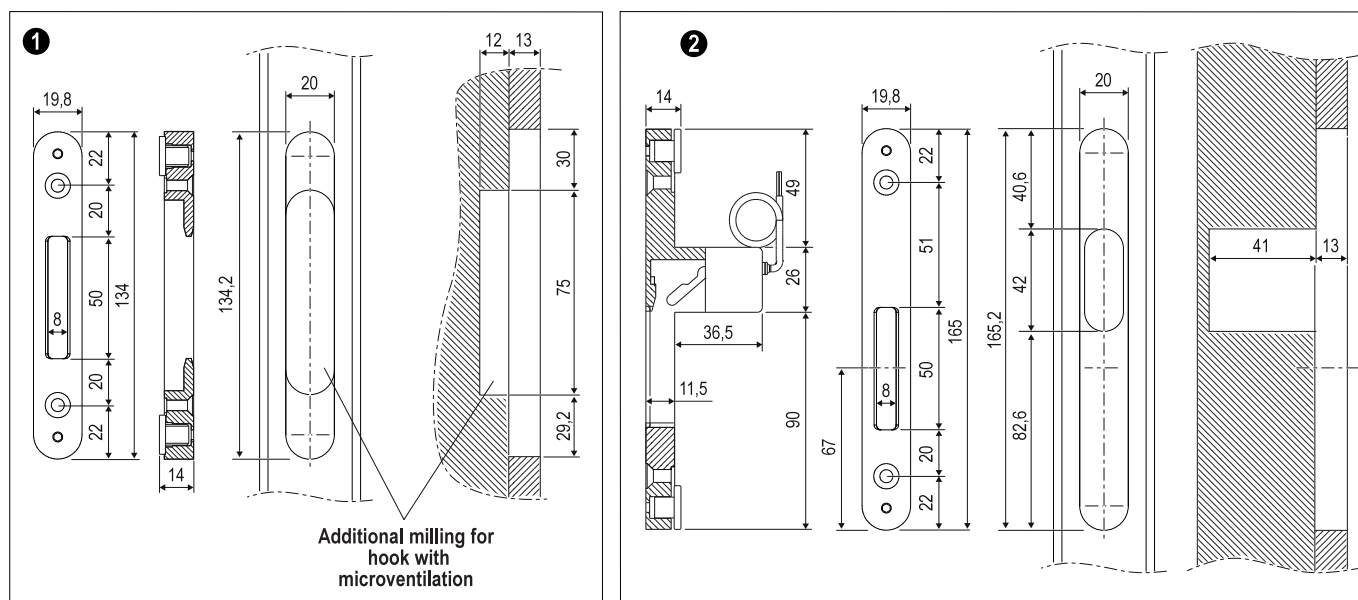

| Ref. | Description | Article | |
|------|-------------------------------------|--------------|--------------|
| ❶ | Striker for hook | G06201.00.01 | G06201.00.02 |
| ❷ | Striker for hook with signal system | G06203.00.01 | G06203.00.02 |

Locking pins

| Article | Ref. | Description | Material | Use | Fastening |
|-------------------------------|------|---|----------|---|--|
| Locking pins | ❶ | Steel threaded pins. | Steel | Fastened to the jamb of the frame, they block the sliding sashes. They are available for wood or PVC and aluminium. | <p>ø10 mm pre-hole for soft wood. ø11 mm pre-hole for hard wood.</p> <p>Fasten the pin using the suitable hook G00746.00.06.</p> <p>Attention: don't use the hammer as it will compromise the pin tightness.</p> <p>Note. To determine the placement of locking pin, please use the jig art. G00746.00.05 (see the chapter "Jigs").</p> |
| Anti-burglar locking pins | ❷ | Steel threaded pins. | | | |
| Pin with ventilation position | ❸ | Threaded pin with double locking position. It allows to close the sash to the frame with a split for ventilation. | | | |

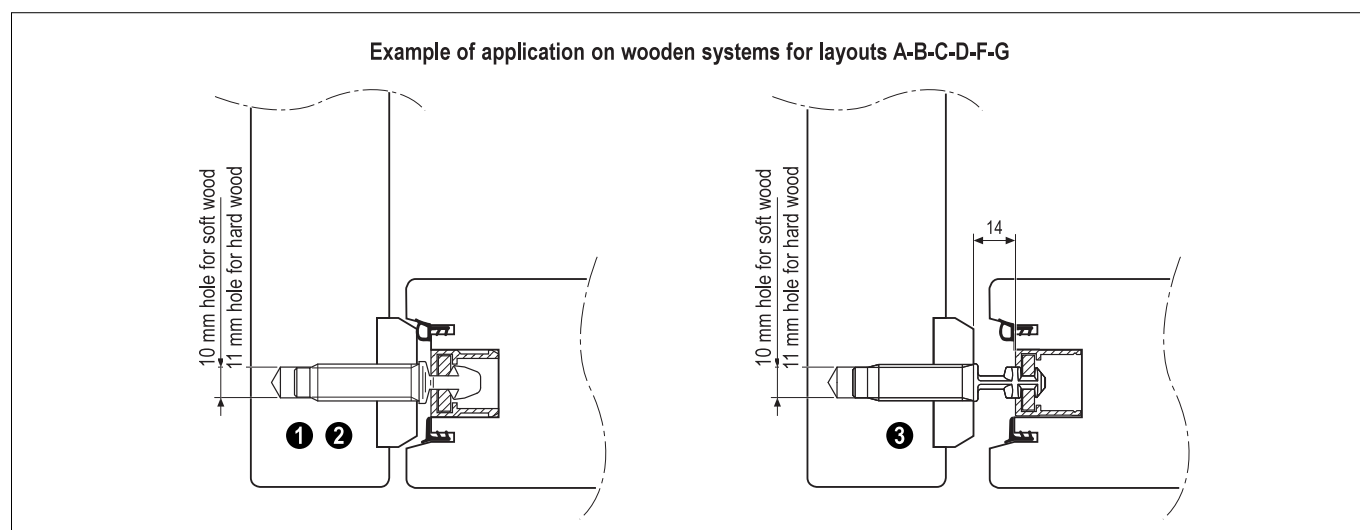
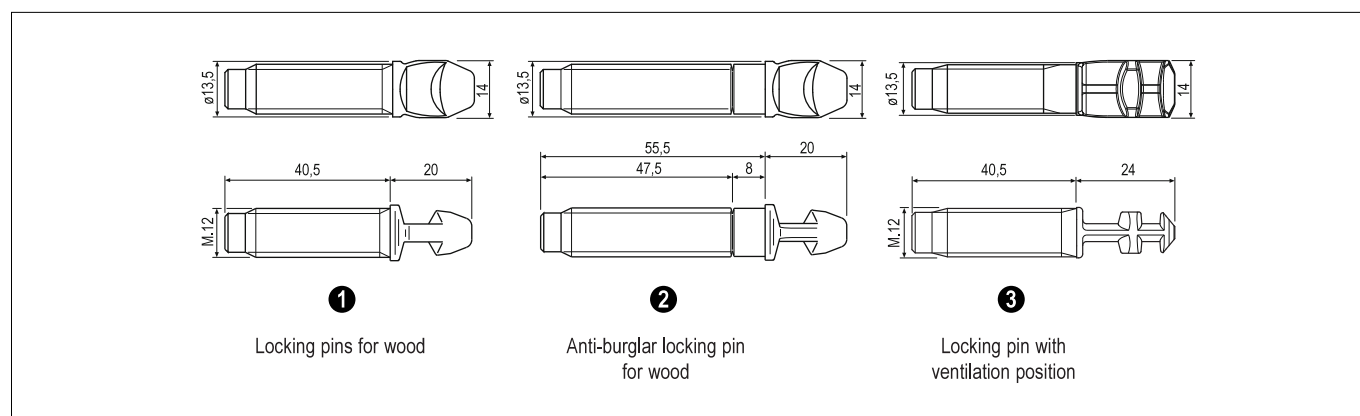

| Ref. | Description | Article |
|------|---|----------------|
| ❶ | Wood | G40728.00.03 * |
| ❷ | Anti-burglar for wood | G40728.00.33 * |
| ❸ | Ventilation for PVC / Aluminium-wood / Wood | G04902.01.00 * |

* **Note.** Not included in the standard kit (to be ordered separately).

Uni-V central point kit

Description

Universal central point kit for all the AGB sliding systems.

Use

The use of Uni-V central point offers many advantages:

- it binds the sashes in closing position;
- keeps the production fast because it doesn't need gasket holder profiles;
- helps the system tightness thanks to the increased gasket;
- helps the sash sliding thanks to wide working tolerances which are able to compensate the natural deformation of wood.

Fastening

- Cut the components (follow the technical manual indications for each sliding system);
- insert the gasket;
- insert the terminal caps;
- fasten the profiles to sashes using screws $\varnothing 3,5 \times 35$;
- insert the screws covering profiles and the brush;
- silicone and cut following the indications of the specific technical manual for each sliding system.

Materials

- EPDM gasket,
- Covering profiles of screws in PVC,
- Extruded aluminium profiles,
- Polypropylene brush.

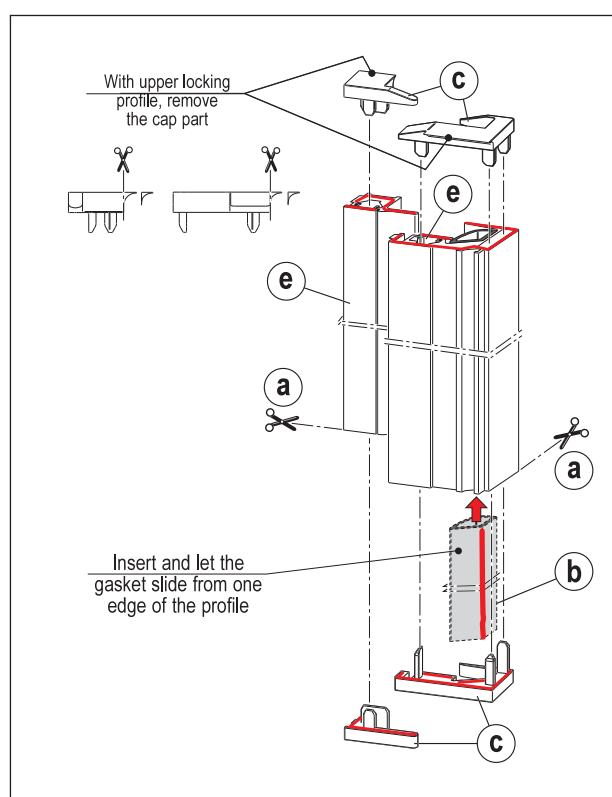
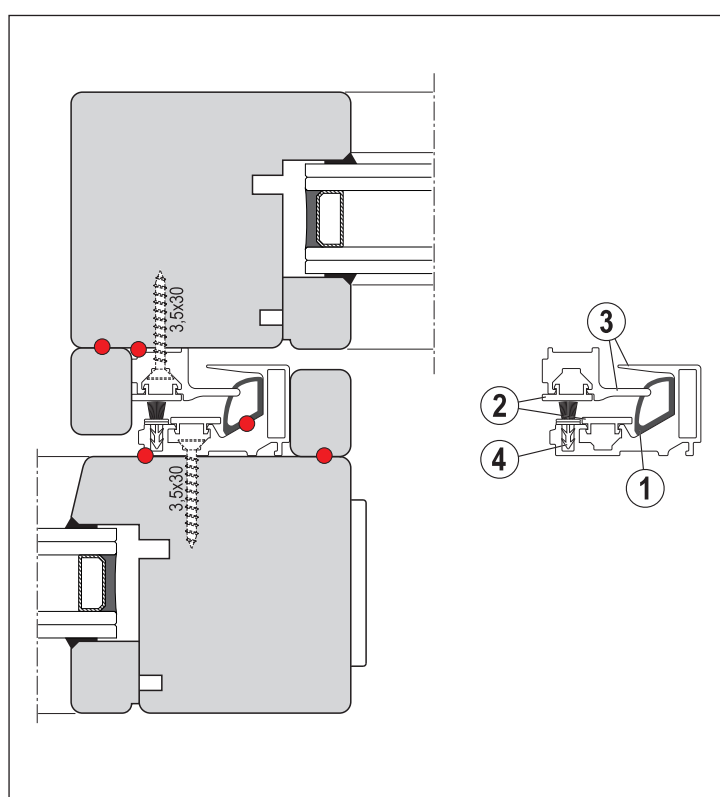

| Ref. | Article | Article code | Finish | Length |
|------|---------------------|--------------|--------|---------|
| 1 | Uni-V point profile | G02208.25.01 | Silver | 2500 mm |
| | | G02208.25.93 | Black | 2500 mm |
| | | G02208.31.01 | Silver | 3100 mm |
| | | G02208.31.93 | Black | 3100 mm |
| | | G02208.40.01 | Silver | 4000 mm |
| | | G02208.40.93 | Black | 4000 mm |

| Ref. | Article | Article code | |
|------|----------|--------------|-------|
| 2 | Caps kit | G01610.DX.93 | Right |
| | | G01610.SX.93 | Left |

Central point kit Uni-V mini

| Article | Ref. | Description | Use | Fastening |
|--------------------|----------|--|--|---|
| Uni-V Mini profile | 1 | Standard central point designed for the application in all the AGB lift&slide systems. | The use of Uni-V Mini central point has many advantages: - it binds the sashes in closing position; - it helps the lift&slide production because it does not require gasket profiles for rebate - it helps the system tightness thanks to the increased gasket - it helps the sashes sliding thanks to great working tolerances which are able to compensate the natural deformations of wood. | a) cut the components (follow the indications of the technical manual according to the lift&slide type to be designed), b) insert the gasket, c) insert the terminal caps, d) fasten the profiles to sashes using screws $\varnothing 3,5 \times 35$, e) insert the covering profiles of screws and the brush, f) silicone and cut following the indications of the dedicated technical manual which concerns the lift&slide type to be designed. |
| Caps kit | 2 | | | |

Materials

- 1) EPDM gasket
- 2) PVC screws covering profiles
- 3) Extruded aluminium profiles
- 4) Polypropylene brush

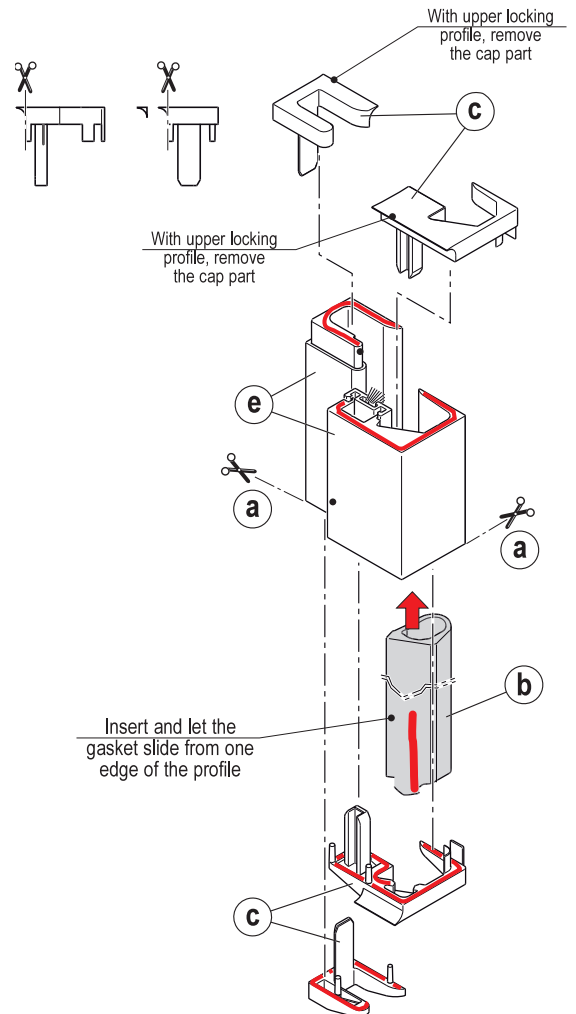
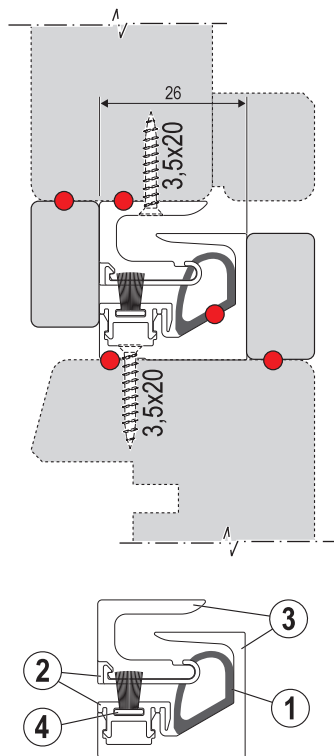

| Ref. | Article | Article code | Length |
|----------|--------------------------|--------------|---------|
| 1 | Uni-V Mini point profile | G02211.25.01 | 2500 mm |
| | | G02211.25.93 | 2500 mm |
| | | G02211.31.01 | 3100 mm |
| | | G02211.31.93 | 3100 mm |
| | | G02211.40.01 | 4000 mm |
| | | G02211.40.93 | 4000 mm |

| Ref. | Article | Article code | |
|----------|----------|--------------|-------|
| 2 | Caps kit | G01623.DX.93 | Right |
| | | G01623.SX.93 | Left |



Alban Giacomo SpA

Headquarters:
Via A. De Gasperi, 75
36060 Romano d'Ezzelino
(Vicenza) Italy