



Alban Giacomo SpA

COMPANY WITH  
QUALITY SYSTEM  
CERTIFIED BY DNV GL  
= ISO 9001 =

---

TECHNICAL MANUAL

LIFT & SLIDE

Intermediate **68** mm

XC Configuration

Layouts **A & E**, Layouts **B & F**

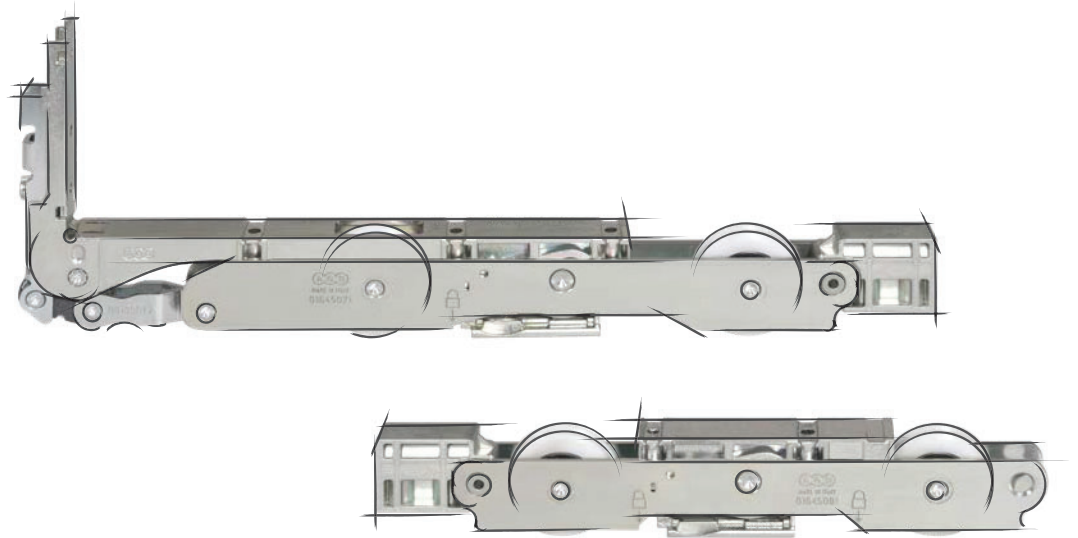

|  |    |
|--|----|
| INTRODUCTION   | 3  |
| Warnings   | 3  |
| Symbology and abbreviations  | 3  |
| CONFIGURATION CHOICE AND CONSTRUCTION CALCULATIONS   | 4  |
| Possible configurations developed in this manual   | 4  |
| LAYOUTS A & E  | 5  |
| Dimensions calculation of sliding sashes   | 5  |
| Hardware diagram with hooks lock   | 6  |
| Hardware diagram with pins lock  | 8  |
| Horizontal section   | 10 |
| Construction details of jambs and listels  | 12 |
| Upper point vertical section with locking profile - fixed sash                             | 13 |
| Upper point vertical section with locking profile - sliding sash                           | 13 |
| Upper point vertical section with thermal pad (only for reduc. upper guide) - fixed sash   | 14 |
| Upper point vertical section with thermal pad (only for reduc. upper guide) - sliding sash | 14 |
| Lower point vertical section - fixed sash  | 15 |
| Lower point vertical section - sliding sash  | 15 |
| Millings - Vertical section, upper point   | 16 |
| Millings - Vertical section, lower point   | 17 |
| Millings - Sliding sash horizontal section   | 18 |
| Millings - Fixed sash horizontal section   | 19 |
| Millings - Central point horizontal section  | 20 |
| Millings - Central point horizontal section for coaxial sashes                             | 21 |
| Formulas of components cut   | 22 |
| LAYOUTS B & F  | 23 |
| Dimensions calculation of sliding sashes   | 23 |
| Hardware diagram with hooks lock   | 24 |
| Hardware diagram with pins lock  | 26 |
| Horizontal section   | 28 |
| Construction details of jambs and listels  | 30 |
| Upper point vertical section   | 31 |
| Wood millings: frame jamb horizontal section   | 32 |
| Wood millings: central point horizontal section  | 33 |
| Wood millings: vertical section of upper frame transom                                     | 33 |
| Construction details, layouts B & F  | 34 |
| Formulas of components cut   | 35 |
| LAYOUTS A & E, LAYOUTS B & F - ASSEMBLY OPERATIONS   | 36 |
| Positioning of central listels on sashes   | 36 |
| Pad application on central jambs   | 36 |
| Realisation of lock holes  | 37 |
| Accessories for single sash configuration with guide 22x22                                 | 38 |
| Accessories for single sash configuration with guide 22x13                                 | 39 |
| Accessories for coaxial sash configuration with guide 22x13                                | 40 |
| Accessories for coaxial sash configuration with guide 22x22                                | 41 |
| Sash assembly  | 42 |
| Locking pins assembly  | 42 |
| Frame corner joint (alternative solution)  | 43 |
| Joint between frame and threshold (with 56 mm thickness frame)                             | 43 |
| Joint between frame and threshold (with 45 mm frame thickness)                             | 44 |
| Use of gas spring kit  | 45 |
| TECHNICAL ATTACHMENTS  | 47 |

## INTRODUCTION

### Warnings



Possible changes regarding accessories, assembly and millings will be constantly reported with the periodic update of this manual. Therefore, we suggest to pay attention to the release of new versions in the website [www.agb.it](http://www.agb.it).







The producers who use the AGB Certification agreement must install glasses with the following minimum requirements: Minimum thickness 44.1/15/33.1 Shatterproof















Using a 45 mm thick frame instead of a 56 mm frame will change the heat transmittance and mechanical resistance characteristics of the door or window. Therefore, this configuration is also covered by AGB cascading. In this manual, both configurations are considered.

### Symbology and abbreviations

|   |   |                               |
|---|---|-------------------------------|
| HB  | = | Sash height                   |
| LB  | = | Sash width                    |
| MET   | = | Frame external measurement    |
| SMT   | = | Frame jamb thickness          |
| SMA   | = | Sash jamb thickness           |
| LBF   | = | Fixed sash width              |
| HET   | = | Frame external height         |
| STST  | = | Frame upper transom thickness |
| LG  | = | Glass width                   |
| HG  | = | Glass height                  |
| H   | = | Component height              |
| L   | = | Component length              |
| Gap   | = | 5 mm                          |
|  | = | Silicone or suitable gasket   |
|  | = | Neutral silicone with Primer  |
|  | = | Pre-hole                      |
|  | = | EPDM tape                     |

Note. All the measurements are in millimeters

|   |   |   |
|---|---|---|
|    | = | Solution detail with high/reduced upper guide |
|    | = | Solution detail with guide 22X13              |
|    | = | Solution detail with guide 22X22              |
|    | = | Detail solution with XC carriages             |
|  | = | Detail solution with XC S-Line carriages      |
|  | = | Detail solution with hooks lock               |
|  | = | Detail solution with pins lock                |
|  | = | Solution with Uni-V central point             |
|  | = | Solution with basic point                     |
|  | = | Solution with central point Easy              |
|  | = | Solution with Uni-V Mini central point        |
|  | = | Reference page number for details             |

## CONFIGURATION CHOICE AND CONSTRUCTION CALCULATIONS

Possible configurations developed in this manual

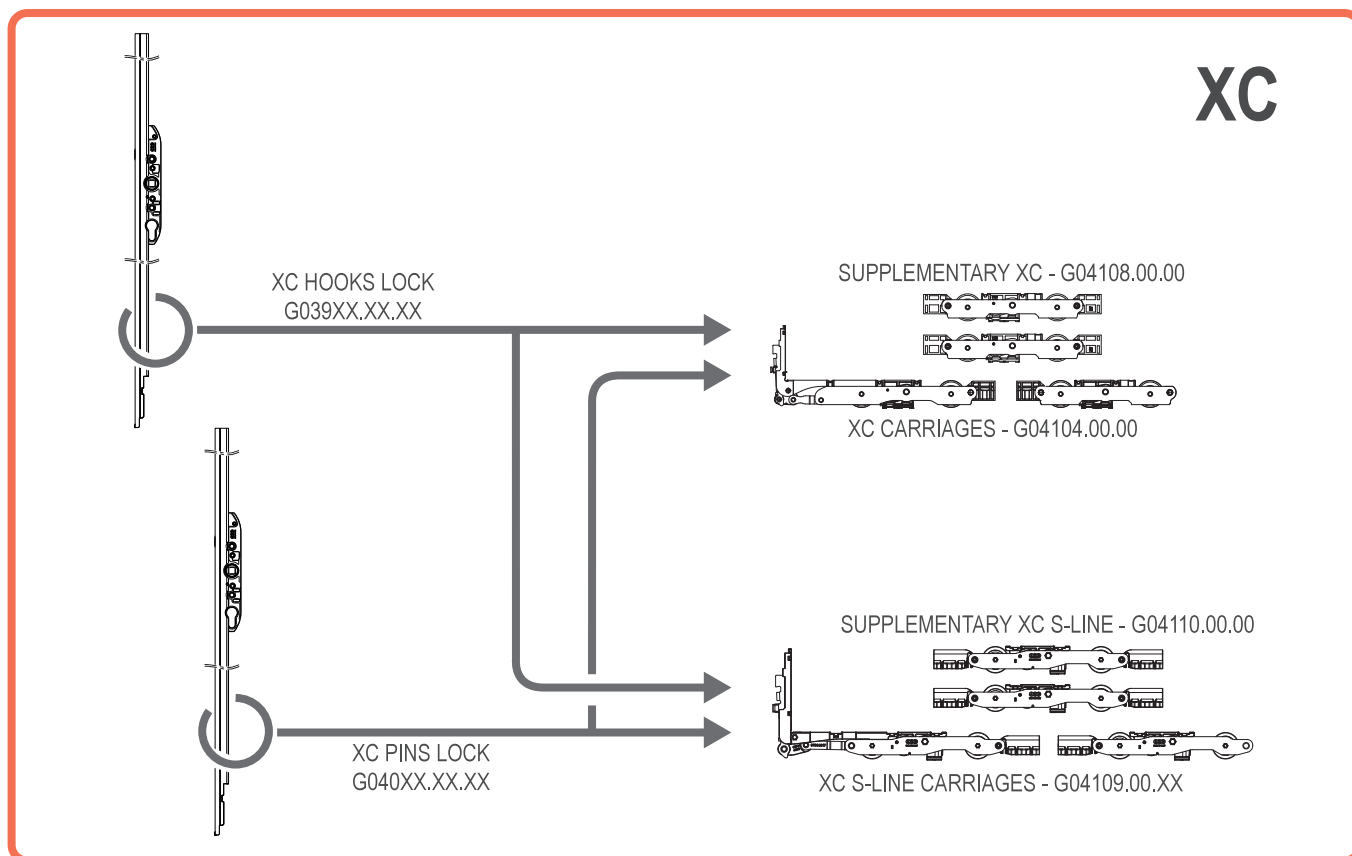



### LAYOUTS A & E

- Sash with one transom in the lower part with possibility to have a basement.
- Vertical external gasket - lower: balloon with vulcanized edge in EPDM.
- Covering internal side gasket of the milling in EPDM.
- Water, air, wind and impact tests made in glass: 44.1/15/33.1 (minimum possible).
- Layout E made with symmetric central point and aluminium pin holder profile and extremity caps for gaps closing.
- External architrave cable with brush (optional).

### Dimensions calculation of sliding sashes

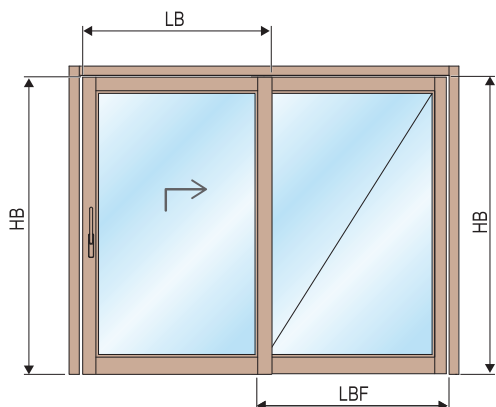

$A = 12$   
 $\Rightarrow HB = HET - (STST + 12 + 21)$

$A = 15$  (guide 22x22)  
 $\Rightarrow HB = HET - (STST + 15 + 21)$

(Tolerance HB  $\pm 0,5$ )

|        | G1 | G2 | G3 |
|--------|----|----|----|
| A = 12 | ✓  | ✓  | ✓  |
| A = 15 | ✗  | ✗  | ✓  |

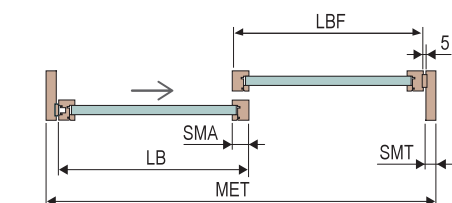
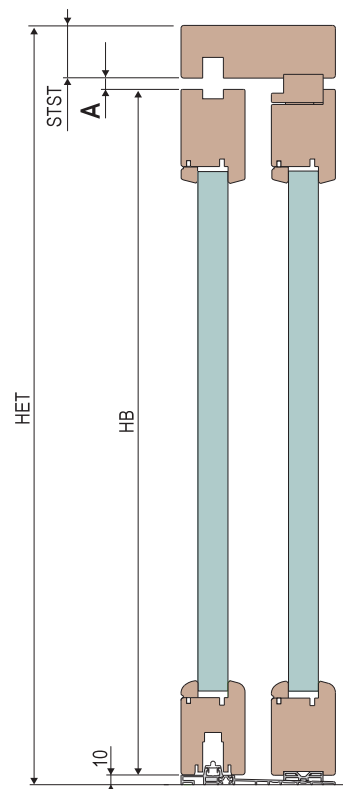

**Layout A**  
 1 fixed sash and 1 sliding sash  
 $LB = [MET - 2 \times (SMT + 5)] : 2 + SMA : 2$   
 Eg.:  $[4000 - 2 \times (56 + 5)] : 2 + 90 : 2$  LB = 1984 mm

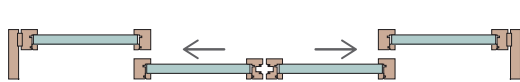

**Layout E**  
 2 fixed sashes and 2 sliding sashes  
 $LB = [MET - (2 \times SMT + 3 \times 5)] : 4 + SMA : 2$



**Layout D**  
 1 fixed sash and 2 sliding sashes  
 $LB = [MET - 2 \times (SMT + 5)] : 4 + SMA : 2$

**Hardware diagram with hooks lock**

- 1 Hooks lock**  
G039EE.03.XX HB=1775-2150 Handle H = 1000  
G039EE.04.XX HB=1925-2400 Handle H = 1000  
G039EE.05.XX HB=2325-2750 Handle H = 1000
- 2 Additional hook kit - G05008.00.00**
- 3 Microventil. additional hook kit - G05010.00.00**
- 4 Second sash hooks lock**  
GR39EE.03.01 HB=1775-2150 Handle H = 1000  
GR39EE.04.01 HB=1925-2400 Handle H = 1000  
GR39EE.05.01 HB=2325-2750 Handle H = 1000
- 5 Hooks extension 500 mm - G04600.01.01**
- 6 Covering profile 1000 mm - G04401.02.01**
- 7 Gas spring kit - GMG702.04.00**
- 8 XC basic carriages kit**  
G04104.00.00 Standard  
G04114.00.00 with adjustable rear carriage
- 9 XC suppl. carriages kit - G04108.00.00**
- 10 XC S-Line carriages kit - G04109.00.00**
- 11 XC S-Line suppl. carriages kit - G04110.00.00**
- 12 Carriages connecting rod**  
G04601.00.01 L=1000 G04601.00.03 L=1800  
G04601.00.02 L=1400 G04601.00.04 L=2700
- 13 Handle fastening plate**  
G05371.M5.00 hole M5  
G05371.M6.00 hole M6
- 14 Anti-burglar plate kit - G05004.00.00**
- 15 Sensors**  
G05006.00.86 Grey  
G05006.00.93 Black  
G05003.00.00 Clip
- 16 Lateral locking profile for hooks lock**  
G01359.03.XX GR3 Predisposit. 2 hooks  
G01359.04.XX GR4 Predisposit. 2 hooks  
G01359.05.XX GR5 Predisposit. 2 hooks  
G01359.13.XX GR3 Predisposit. 3 hooks  
G01359.14.XX GR4 Predisposit. 3 hooks  
G01359.15.XX GR5 Predisposit. 3 hooks  
G01359.23.XX GR3 Predis. signal system  
G01359.24.XX GR4 Predis. signal system  
G01359.25.XX GR5 Predis. signal system
- 17 Extension for lock.prof. for hooks lock**  
G01360.01.XX L=500
- 18 Coax. sashes lock. prof. for hooks lock + caps**  
G01373.13.XX L=2075 HB=1775-2150 with hooks strik.  
G01373.14.XX L=2325 HB=1925-2400 with hooks strik.  
G01373.15.XX L=2750 HB=2325-2750 with hooks strik.
- 19 Extens. lock.prof. coax sashes for hooks, 500 mm**  
G01364.01.XX with hooks striker
- 20 Striker for lock hook - G06201.00.XX**
- 21 Strik. for hook lock with signal syst. - G06203.00.XX**
- 22 Central pad and caps kit - Easy and Uni-V**  
G0028B.00.93
- 23 Embedded upper guide 22x13**  
G01000.01.XX L=3000 G01000.04.XX L=6000  
G01000.02.XX L=4000 G01000.14.XX L=7000  
G01000.03.XX L=5000
- 24 Shaped cap for "C" track 22x13 (B)**
- 25 Shaped cap for low. rail (B) (C) (F)**
- 26 Rear lower covering cap (B) (F)**
- 27 Cap and glider for front upper guide (B)**
- 28 Cap and glider for rear upper guide (B)**
- 29 Embedded guide reduced door stop - G0204.00.JJ.702**
- 30 Embedded upper guide 22x22**  
G01002.01.XX L=3000 G01002.04.XX L=6000  
G01002.02.XX L=4000 G01002.05.XX L=7000  
G01002.03.XX L=5000
- 31 Shaped cap for embedded guide 22x22 (C)**
- 32 Front glider (C)**
- 33 Rear glider (C)**
- 34 Rear lower cap (C)**
- 35 Glider fastening device (C)**
- 36 Steiker (C) (E)**
- 37 Cover (C)**
- 38 Magnetic striker (D) (E)**
- 39 Opening brake (D)**
- 40 Closing brake (E)**
- 41 Reduced upper guide**  
G01734.01.XX L=3000 G01734.04.XX L=6000  
G01734.02.XX L=4000 G01734.14.XX L=7000  
G01734.03.XX L=5000
- 42 Shaped cap for upper guide (F)**
- 43 2 mm adapter (B) (C) (F)**
- 44 Terminal cap for lock (F)**
- 45 Rear upper cov. cap (F)**
- 46 Door stop**  
G00204.00.91 White G00204.00.93 Black  
G00204.00.86 Grey
- 47 Upper locking profile**  
G02403.15.01 L=1500  
G02403.20.01 L=2000  
G02403.30.01 L=3000
- 48 Upper locking profile**  
G02403.15.01 L=1500  
G02403.20.01 L=2000  
G02403.30.01 L=3000
- 49 Uni-V central point caps kit**  
G01610.DX.93 Right  
G01610.SX.93 Left
- 50 Uni-V Mini central point kit**  
G02211.25.KK L=2500 G02211.40.KK L=4000  
G02211.31.KK L=3100
- 51 Uni-V Mini central point caps kit**  
G01623.DX.93 Destro G01623.SX.93 Left
- 52 Low threshold with thermal cut**  
G01741.01.XX L=3000  
G01741.02.XX L=4000  
G01741.03.XX L=5000  
G01741.04.XX L=6000
- 53 Snap-in rail**  
G02739.01.XX L=3000  
G02739.02.XX L=4000  
G02739.03.XX L=5000  
G02739.04.XX L=6000
- 54 Fixed sash supp. prof. for low threshold**  
G01742.01.00 L=1500  
G01742.02.00 L=2000  
G01742.03.00 L=2500  
G01742.04.00 L=3000
- 55 Fastening basic kit - G01728.00.27**
- 56 Compensator caps kit for 45 jamb dist. 10 and 28**  
G01432.DX.JJ Layout A right  
G01432.SX.JJ Layout A left  
G01432.00.JJ Layouts D & E
- 57 External side gasket (balloon) (G)**  
G020DX.09.93 - G020SX.09.93 L1500 x H2500  
G02000.08.93 L3000 x H3000
- 58 Internal side gasket L150 m - G02004.15.93 (G)**
- 59 PVC upper flexible gasket**  
G00733.02.01 L=40  
G00733.02.02 L=200
- 60 Flexible gasket for central point**  
G00733.01.01 L=40 G00733.04.01 L=40  
G00733.01.02 L=200 G00733.04.02 L=200
- 61 Brush for decompression chamber**  
G02002.16.00 L=1600 G02002.31.00 L=3100  
G02002.25.00 L=2500 G02002.31.20 L=3100 (tube)  
G02002.25.20 L=2500 (tube)
- 62 Upper thermal pad for reduced guide**  
G01413.12.75 75 mm
- 63 Expanded PVC gasket for rails - G00733.06.00**
- 64 EPDM gasket - G01416.17.15**
- 65 XC anti-derailed device - G01611.02.00**
- 66 Rod guide - G05102.00.00**
- 67 S-Line anti-derailed device - G01611.01.00**
- 68 S-Line rod guide - G05104.00.00**
- 69 Cap for supporting profile - G00728.01.31**
- 70 Connecting kit jamb-transom - G00728.00.23**
- 71 Handle**

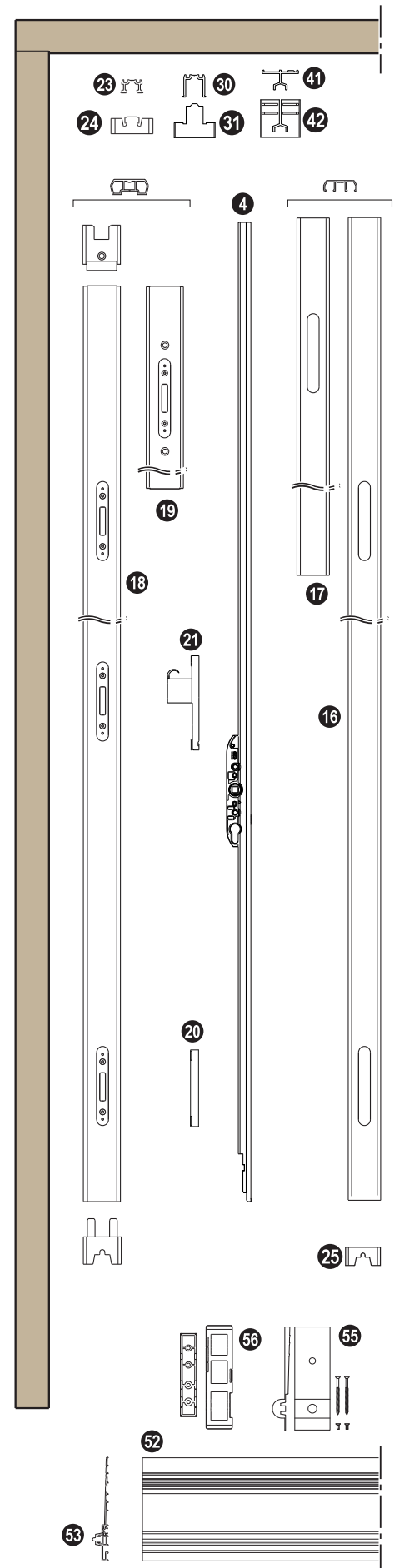

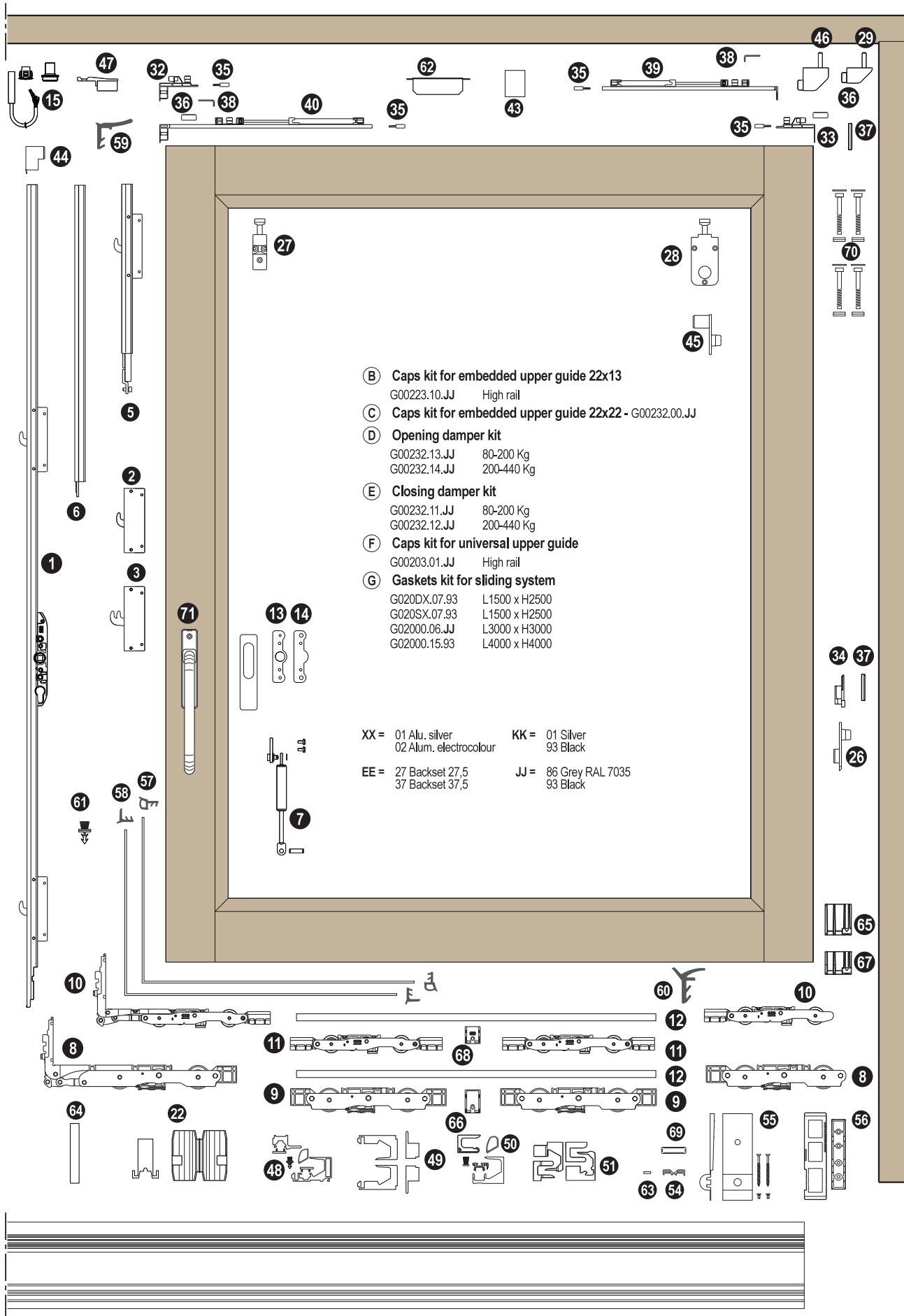

**Hardware diagram with pins lock**

- 1 Pins lock**  
G040EE.01.XX Handle H = 400 SH=800-1200  
G040EE.02.XX Handle H = 400 SH=1170-1800  
G040EE.03.XX Handle H = 1000 SH=1770-2150  
G040EE.04.XX Handle H = 1000 SH=1920-2400  
G040EE.05.XX Handle H = 1000 SH=2401-2750
- 2 Pins extension 500 mm** - G04401.01.01
- 3 Covering profile 1000 mm** - G04401.02.01
- 4 Gas spring kit** - GMG702.04.00
- 5 XC basic carriages kit** - G04104.00.00
- 6 XC suppl. carriages kit** - G04108.00.00
- 7 XC S-Line carriages kit** - G04109.00.00
- 8 XC S-Line supp. carriages kit** - G04110.00.00
- 9 Carriages connecting rod**  
G04601.00.01 L=1000 G04601.00.03 L=1800  
G04601.00.02 L=1400 G04601.00.04 L=2700
- 10 Handle fastening plate**  
G05371.M5.00 hole M5  
G05371.M6.00 hole M6
- 11 Anti-burglar plate kit** - G05004.00.00
- 12 Sensors**  
G05006.00.86 Grey  
G05006.00.93 Black  
G05003.00.00 Clip
- 13 Pin holder profile for lateral point**  
G01341.00.XX L=1800 HB=800-1800  
G01341.01.XX L=2900 HB=1770-2900  
G01341.02.XX L=2900 HB=2401-2900
- 14 Lock. prof. for coaxial sashes + caps**  
G01361.01.XX L=1125 HB=810-1200  
G01361.02.XX L=1725 HB=1175-1800  
G01361.03.XX L=2075 HB=1775-2150 with caps  
G01361.04.XX L=2325 HB=1925-2400  
G01361.05.XX L=2750 HB=2325-2750  
  
G01340.01.XX L=1125 HB=810-1200  
G01340.02.XX L=1725 HB=1175-1800  
G01340.03.XX L=2075 HB=1775-2150 with caps and  
G01340.04.XX L=2325 HB=1925-2400 ventilation pin  
G01340.05.XX L=2750 HB=2325-2750
- 15 Coax. sashes lock. prof. extens. for pins, 500 mm**  
G01361.97.XX
- 16 Coax. sashes lock. prof. extens. for pins, 1000 mm**  
G01757.00.XX
- 17 Pin**  
G40728.00.03 for closing  
G04902.01.00 for ventilation  
G40728.00.33 for anti-burglar closing
- 18 Central pad and caps kit** - layouts A Easy and Uni-V  
G0028B.00.93
- 19 Embedded upper guide 22x13**  
G01000.01.XX L=3000 G01000.04.XX L=6000  
G01000.02.XX L=4000 G01000.14.XX L=7000  
G01000.03.XX L=5000
- 20 Shaped cap for "C" track 22x13 (B)**
- 21 Shaped cap for low. rail (B) (C) (F)**
- 22 Rear low. covering cap (B) (F)**
- 23 Cap and glider for front upper guide (B)**
- 24 Cap and glider for rear upper guide (B)**
- 25 Reduc. door stop for embedd. guide** - G0204.00.JJ.702
- 26 Embedded upper guide 22x22**  
G01002.01.XX L=3000 G01002.04.XX L=6000  
G01002.02.XX L=4000 G01002.05.XX L=7000  
G01002.03.XX L=5000
- 27 Shaped cap for embedd. guide 22x22 (C)**
- 28 Front glider (C)**
- 29 Rear glider (C)**
- 30 Rear lower pad (C)**
- 31 Glider fastening device (C)**
- 32 Striker (C) (E)**
- 33 Cover (C)**
- 34 Magnetic striker (D) (E)**
- 35 Opening brake (D)**
- 36 Closing brake (E)**
- 37 Reduced upper guide**  
G01734.01.XX L=3000 G01734.04.XX L=6000  
G01734.02.XX L=4000 G01734.14.XX L=7000  
G01734.03.XX L=5000
- 38 Shaped cap for upper guide (F)**
- 39 2 mm thick. (B) (C) (F)**
- 40 Terminal cap for lock (F)**
- 41 Rear upper covering cap (F)**
- 42 Door stop**  
G00204.00.91 White G00204.00.93 Black  
G00204.00.86 Grey
- 43 Upper locking profile**  
G02403.15.01 L=1500  
G02403.20.01 L=2000  
G02403.30.01 L=3000
- 44 Uni-V central point kit**  
G02208.25.KK L=2500  
G02208.31.KK L=3100  
G02208.40.KK L=4000
- 45 Uni-V central point caps kit**  
G01610.DX.93 Destro  
G01610.SX.93 Sinistro
- 46 Uni-V Mini central point kit**  
G02211.25.KK L=2500 G02211.40.KK L=4000  
G02211.31.KK L=3100
- 47 Uni-V Mini central point caps kit**  
G01623.DX.93 Right G01623.SX.93 Left
- 48 Low threshold with thermal cut**  
G01741.01.XX L=3000  
G01741.02.XX L=4000  
G01741.03.XX L=5000  
G01741.04.XX L=6000
- 49 Snap-in rail**  
G02739.01.XX L=3000  
G02739.02.XX L=4000  
G02739.03.XX L=5000  
G02739.04.XX L=6000
- 50 Fixed sash supp. profile for low threshold**  
G01742.01.00 L=1500  
G01742.02.00 L=2000  
G01742.03.00 L=2500  
G01742.04.00 L=3000
- 51 Basic fastening kit** - G01728.00.27
- 52 Compensator caps kit for 45 jamb dist. 10 and 28**  
G01432.DX.JJ layout A right  
G01432.SX.JJ layout A left  
G01432.00.JJ layouts D & E
- 53 External side gasket (balloon) (G)**  
G020DX.09.93 - G020SX.09.93 L1500 x H2500  
G02000.08.93 L3000 x H3000
- 54 Internal side gasket L150 m** - G02004.15.93 (G)
- 55 PVC upper flexible gasket**  
G00733.02.01 L=40  
G00733.02.02 L=200
- 56 Flexible gasket for central point**  
G00733.01.01 L=40 G00733.04.01 L=40  
G00733.01.02 L=200 G00733.04.02 L=200
- 57 Brush for decompression chamber**  
G02002.16.00 L=1600 G02002.31.00 L=3100  
G02002.25.00 L=2500 G02002.31.20 L=3100 (tube)  
G02002.25.20 L=2500 (tube)
- 58 Upper thermal pad for reduced guide**  
G01413.12.75 75 mm
- 59 Expand. PVC gasket for rails** - G00733.06.00
- 60 EPDM gasket** - G01416.17.15
- 61 XC anti-derailed device** - G01611.02.00
- 62 Rod guide** - G05102.00.00
- 63 S-Line anti-derailed device** - G01611.01.00
- 64 S-Line rod guide** - G05104.00.00
- 65 Cap for supporting profile** - G00728.01.31
- 66 Connecting kit jamb - transom** - G00728.00.23
- 67 Handle**

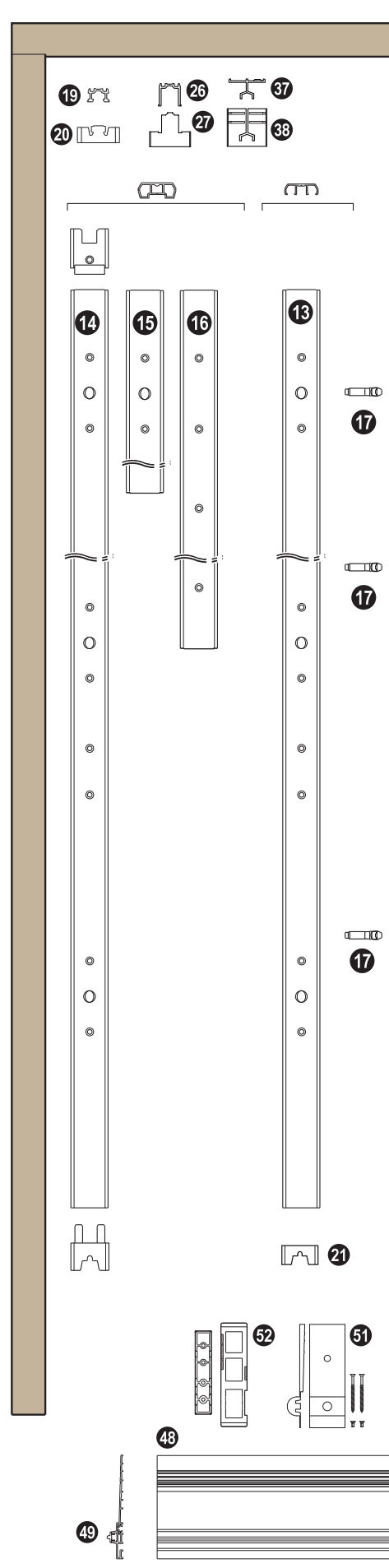

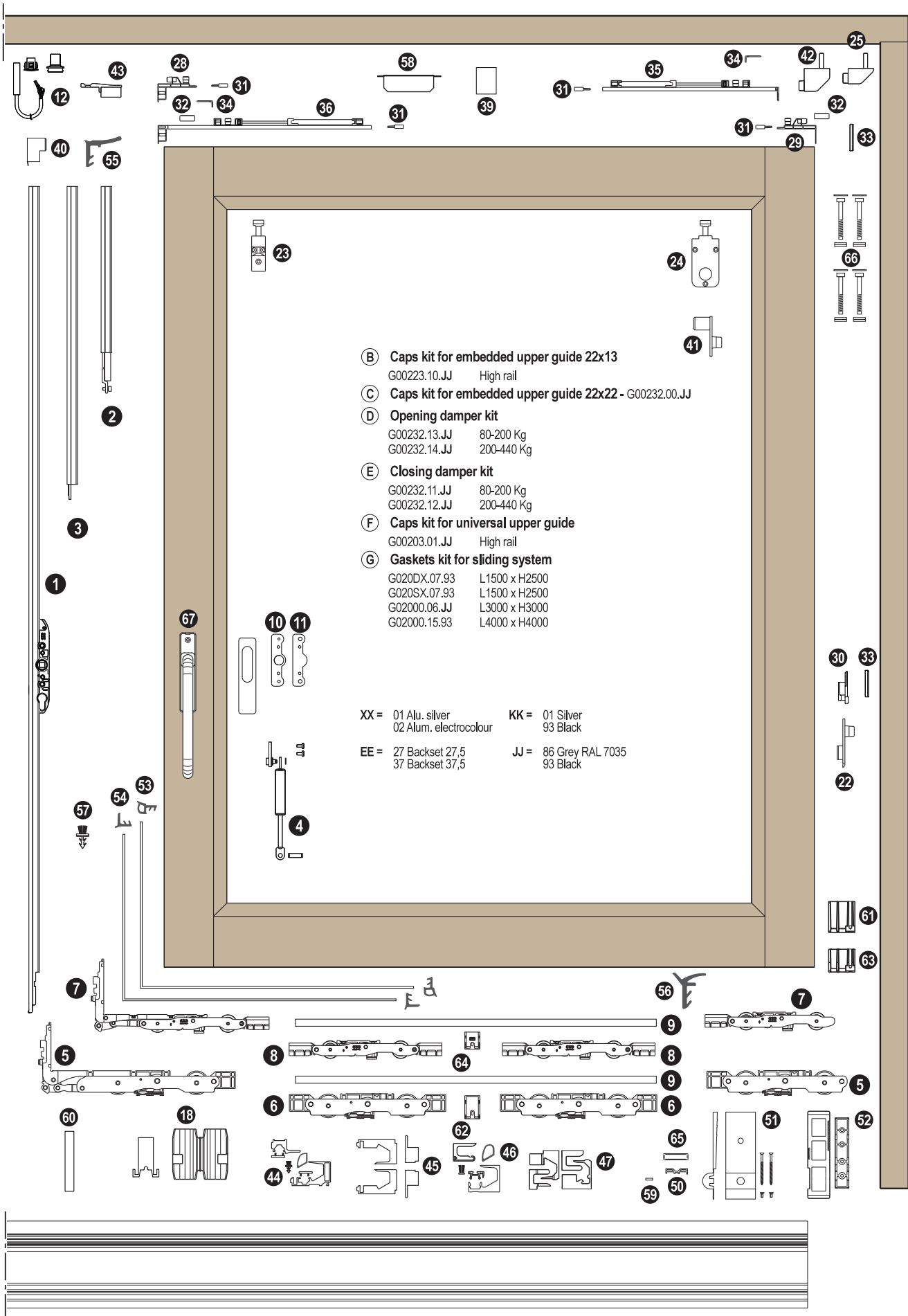

Horizontal section

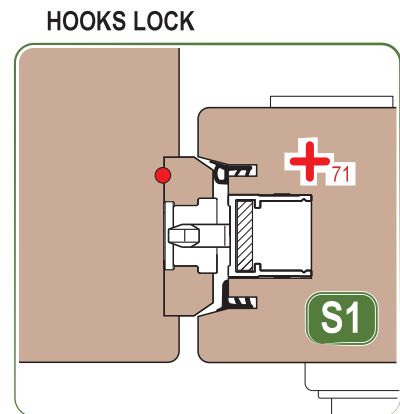
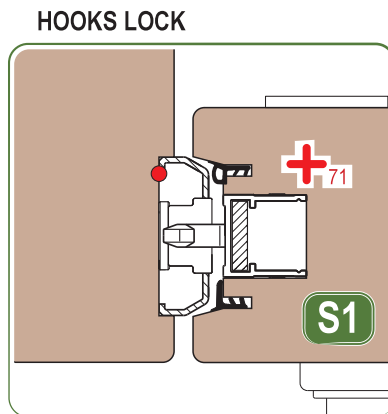
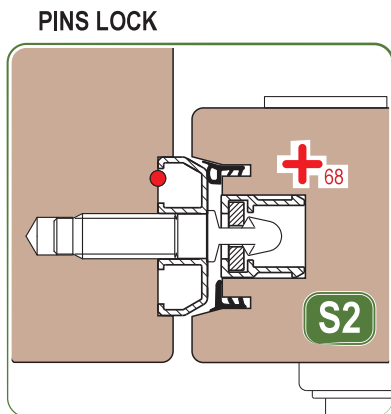
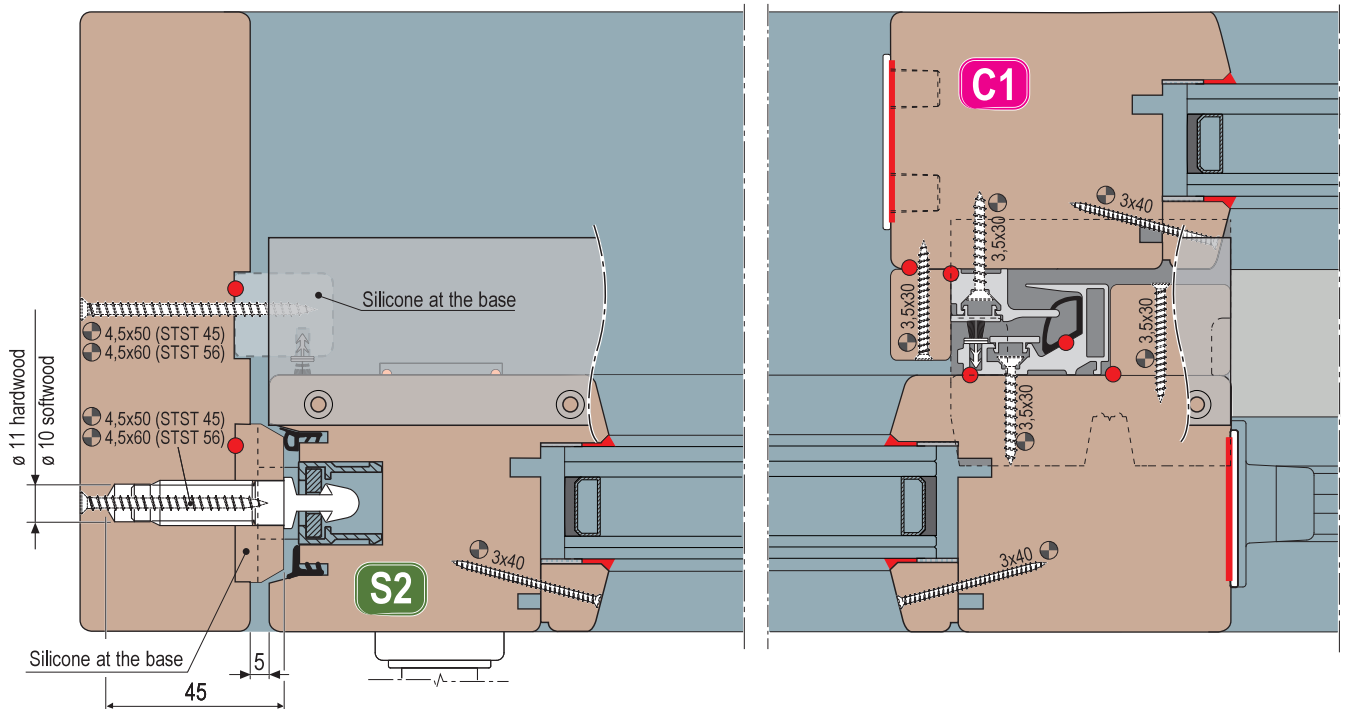

**COAXIAL SASHES CENTRAL POINT**  
(with pins lock)

**COAXIAL SASHES CENTRAL POINT**  
(with hooks lock)

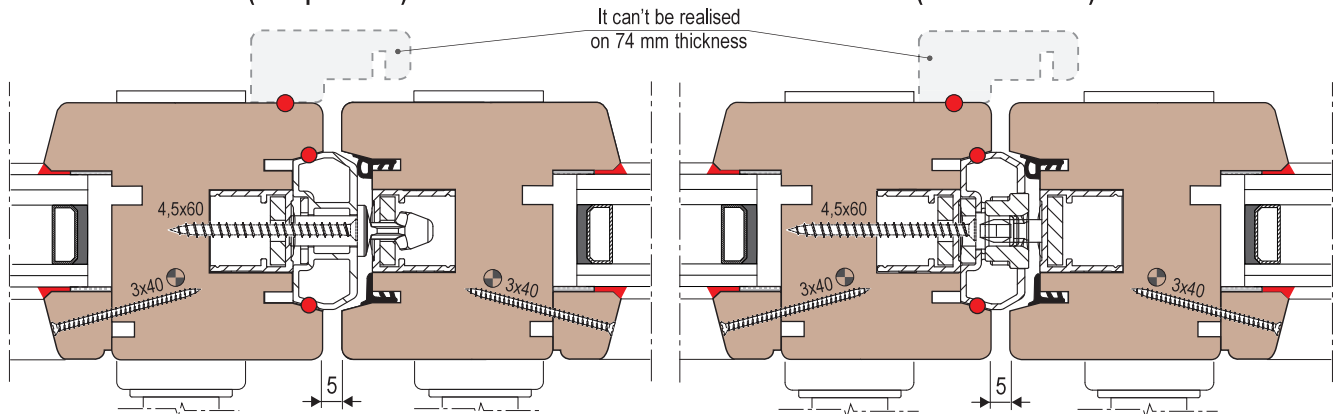

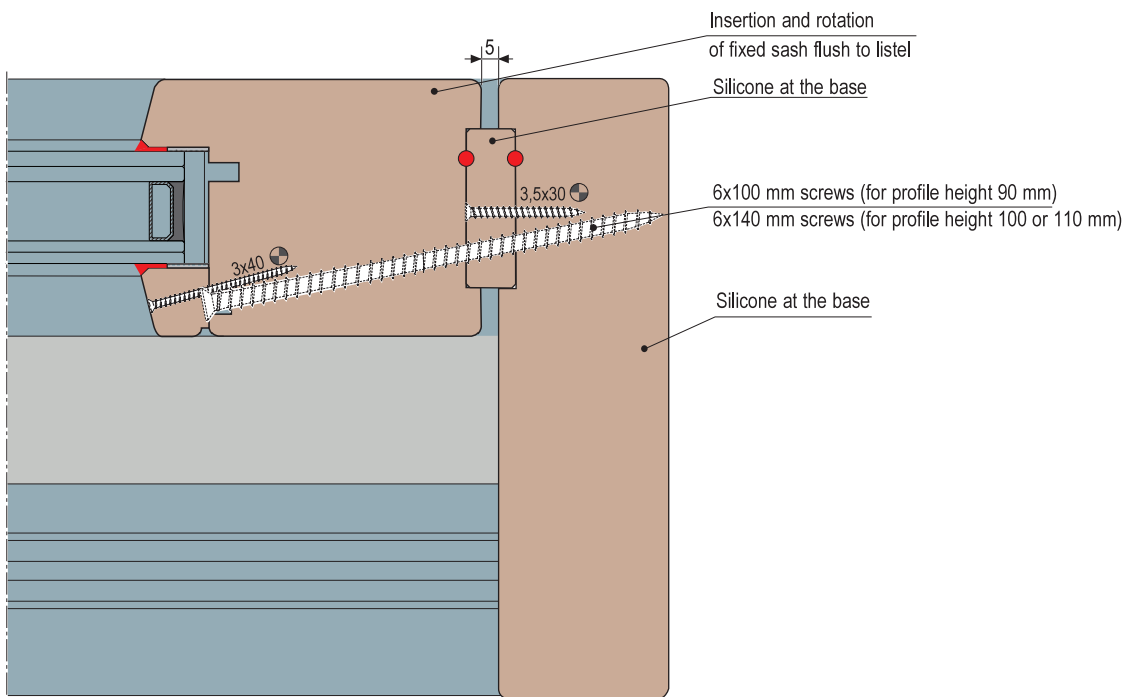

**Uni-V**

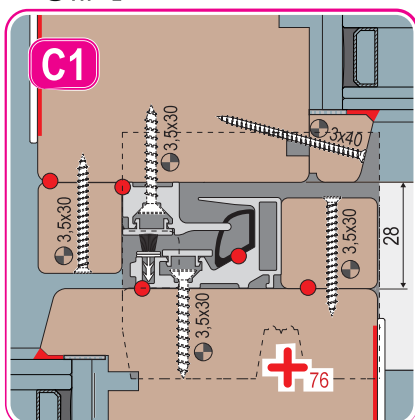

Align the pad to the sash jamb

**Base**

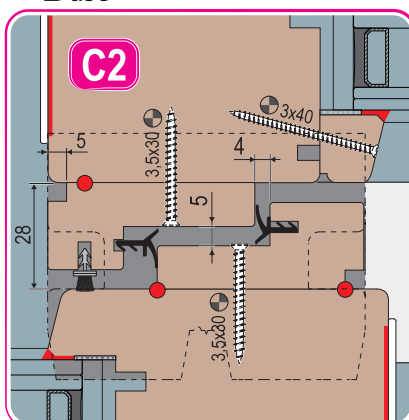

Align the pad to the sash jamb

|                        | <b>Uni-V</b> | <b>Uni-V Mini</b> |
|------------------------|--------------|-------------------|
| Sash section width 74  | X = 26       | X = 34            |
| Sash section width 90  | X = 16       | X = 18            |
| Sash section width 100 | X = 6        | X = 8             |
| Sash section width 110 | -            | -                 |

**Easy**

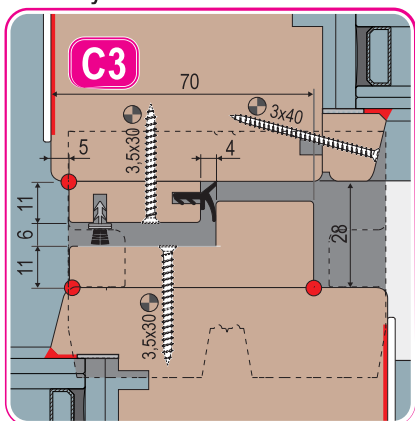

Align the pad to the sash jamb

**Uni-V Mini**

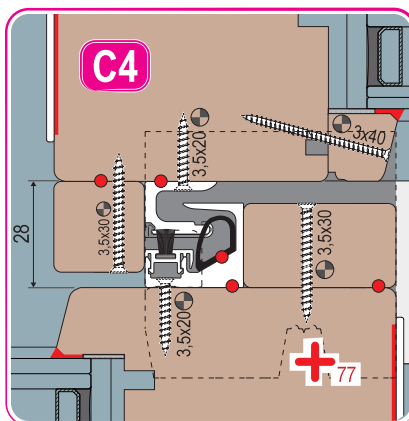

Align the pad to the sash jamb

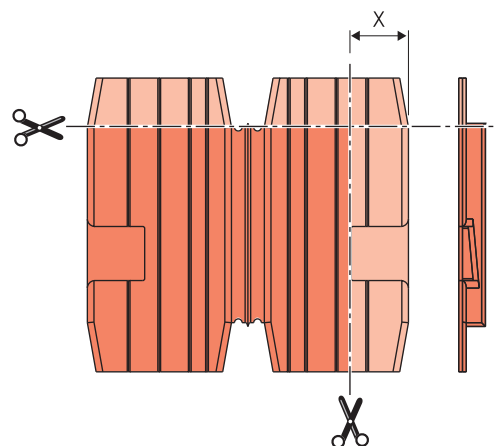



### Construction details of jambs and listels



As an example, the picture represents a case with 22X22 upper guide; the use of other guides needs different accessories even if they are assembled in the same way.

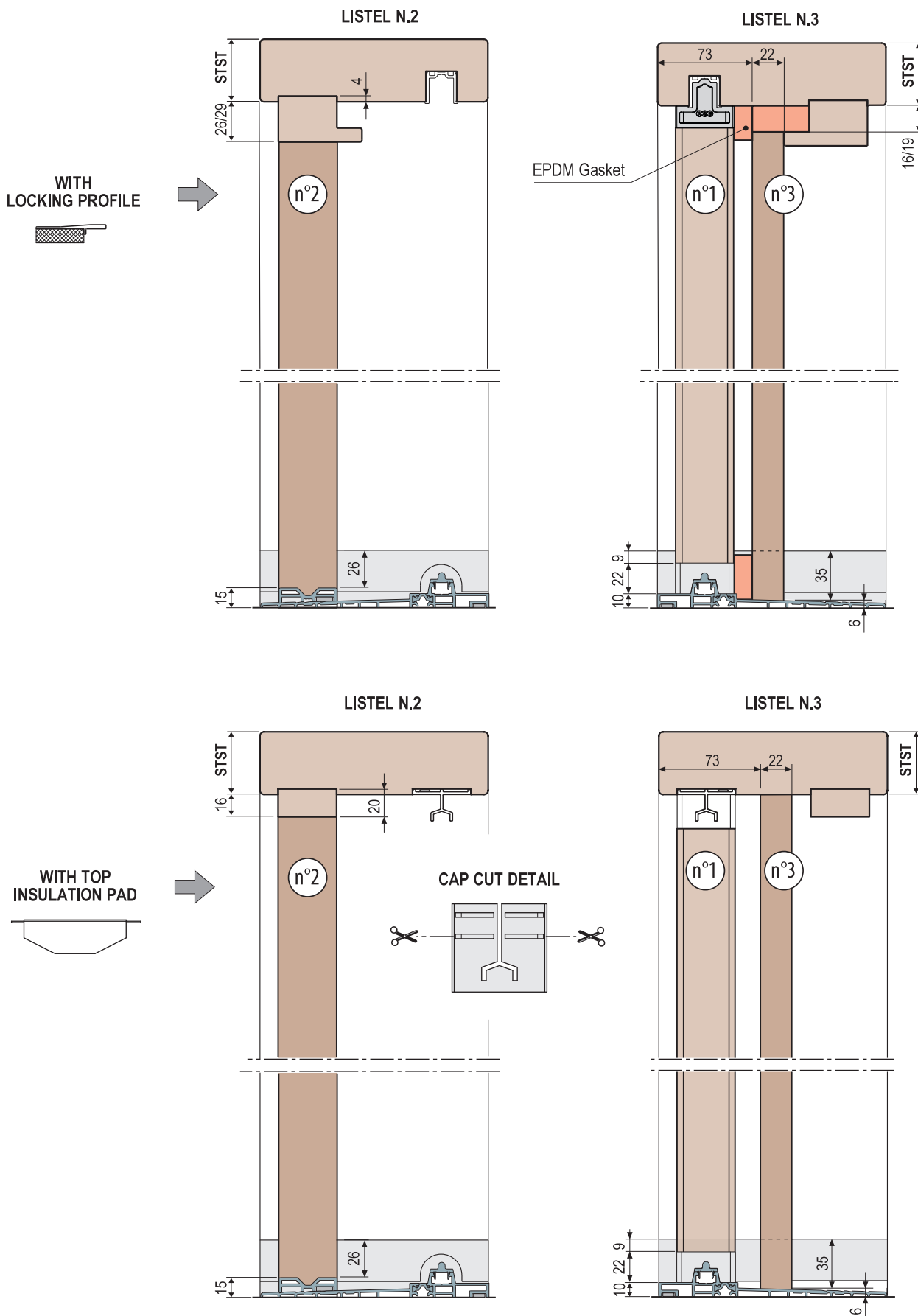



**Upper point vertical section with locking profile - fixed sash**

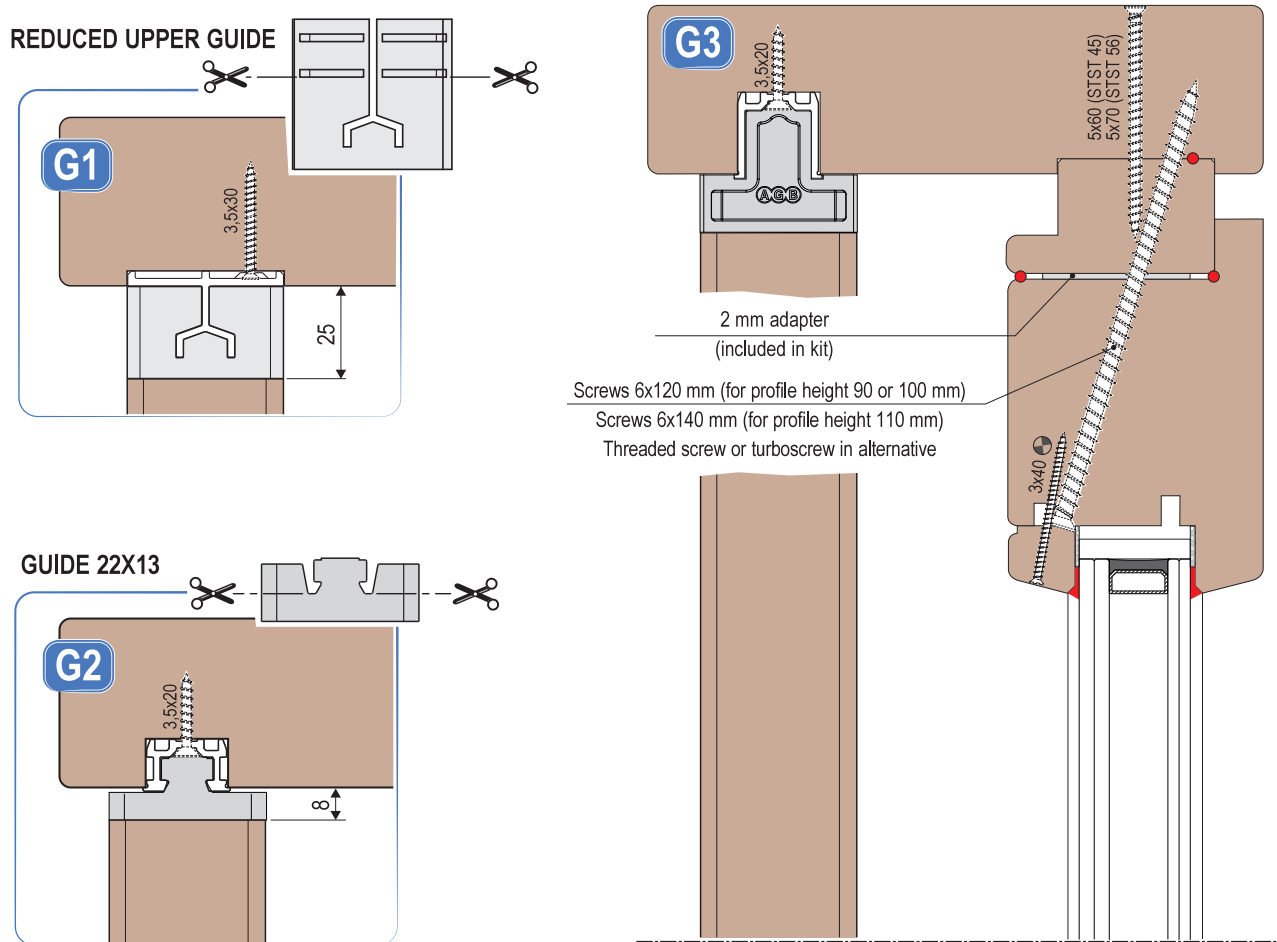

**Upper point vertical section with locking profile - sliding sash**

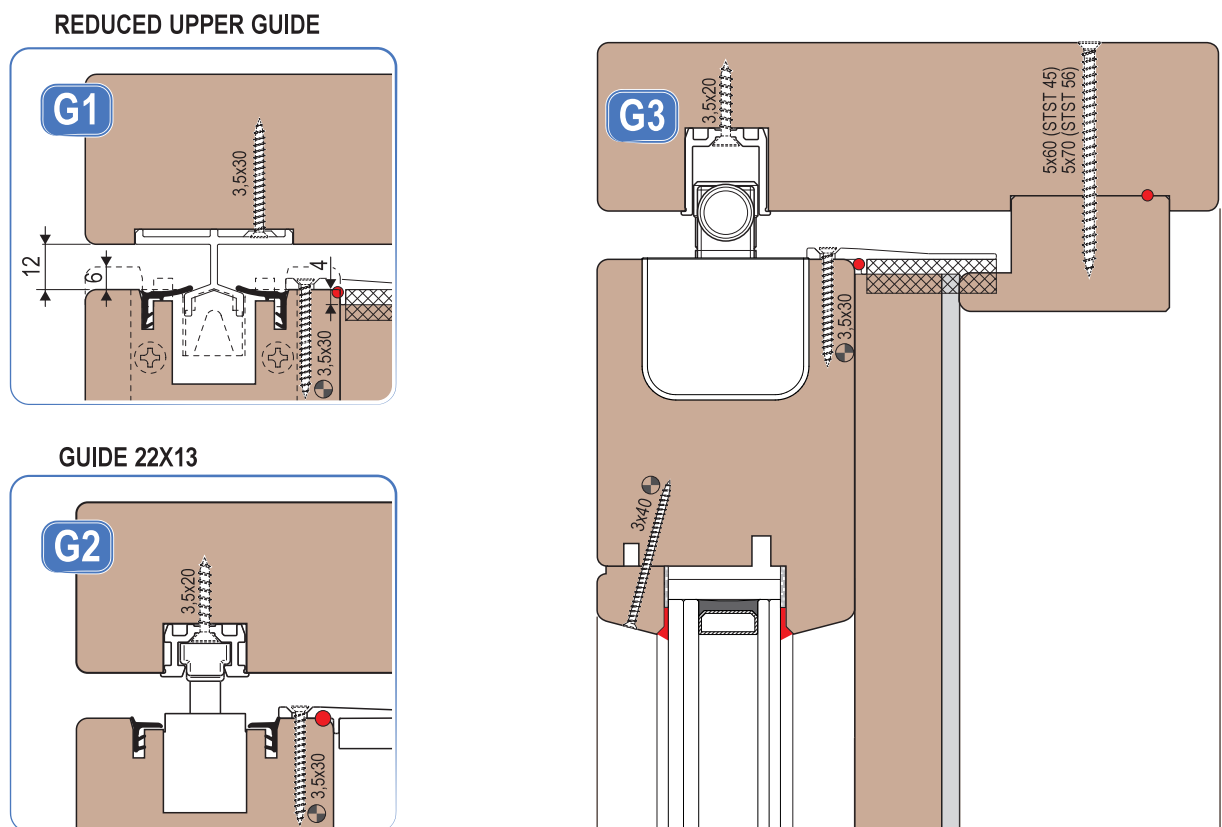

Upper point vertical section with thermal pad (only for reduc. upper guide) - fixed sash

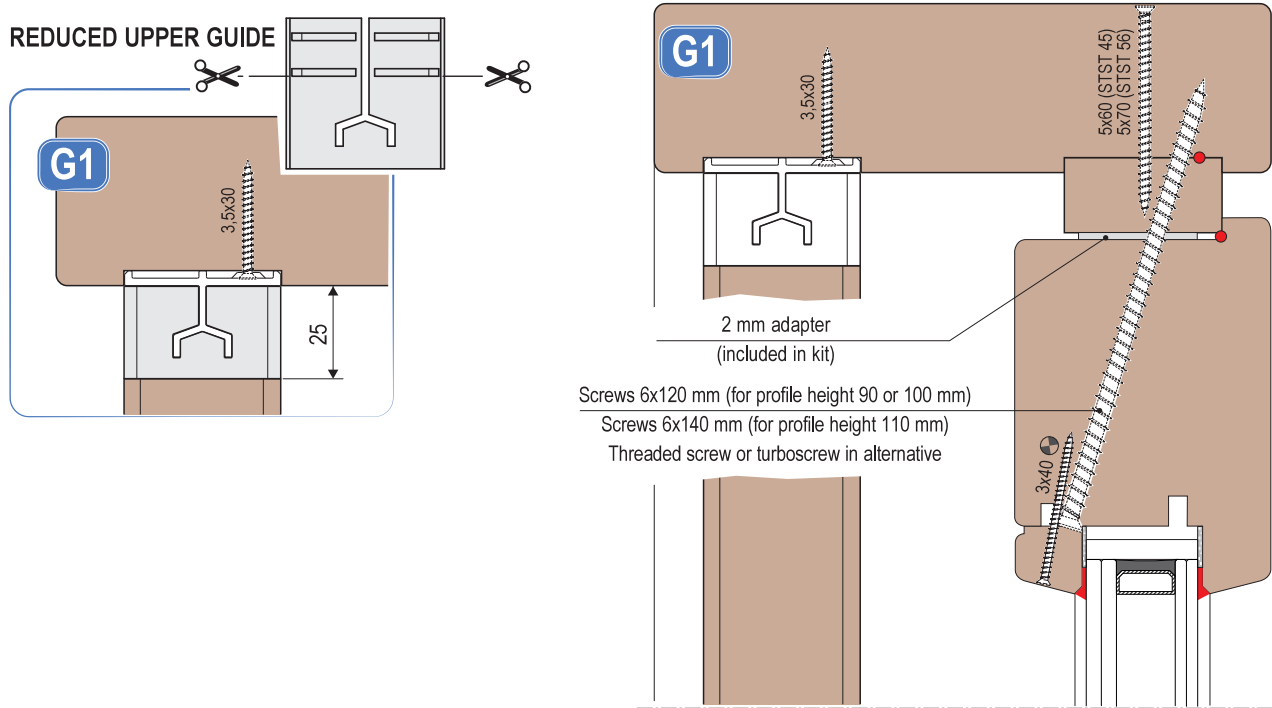

Upper point vertical section with thermal pad (only for reduc. upper guide) - sliding sash

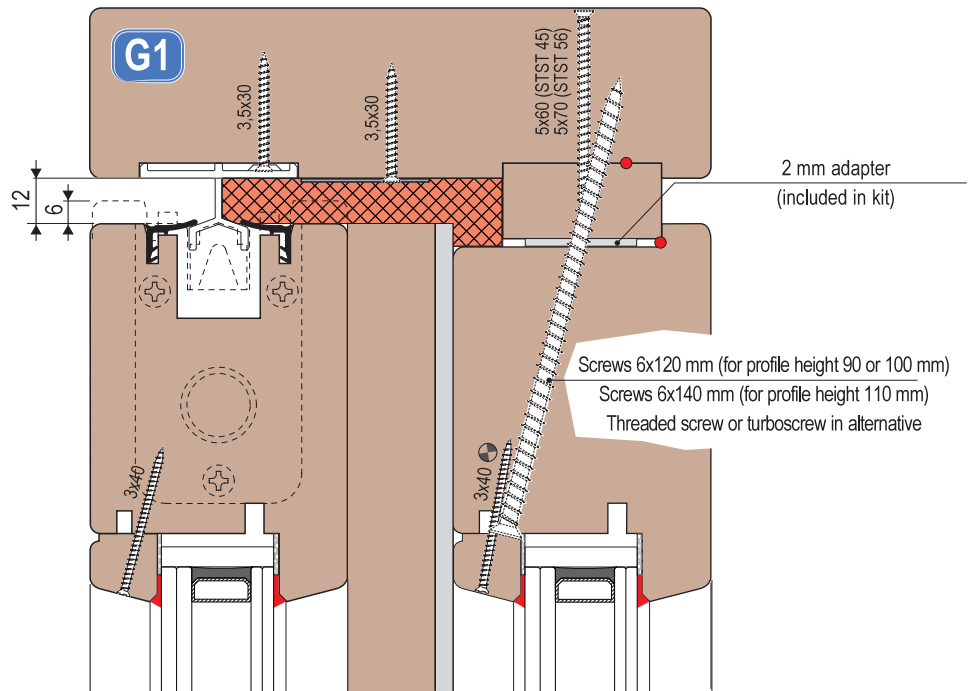

Lower point vertical section - fixed sash

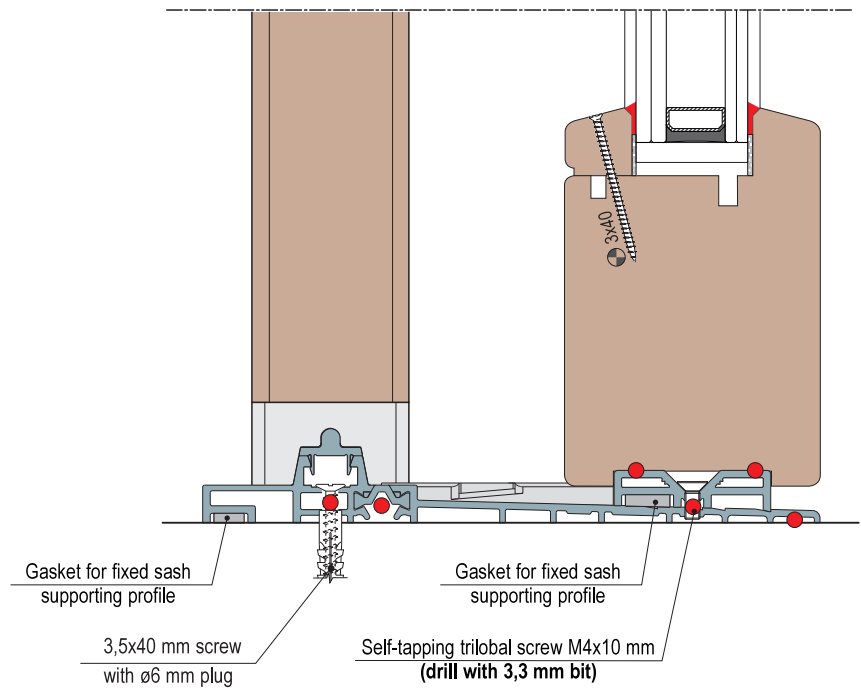

Lower point vertical section - sliding sash

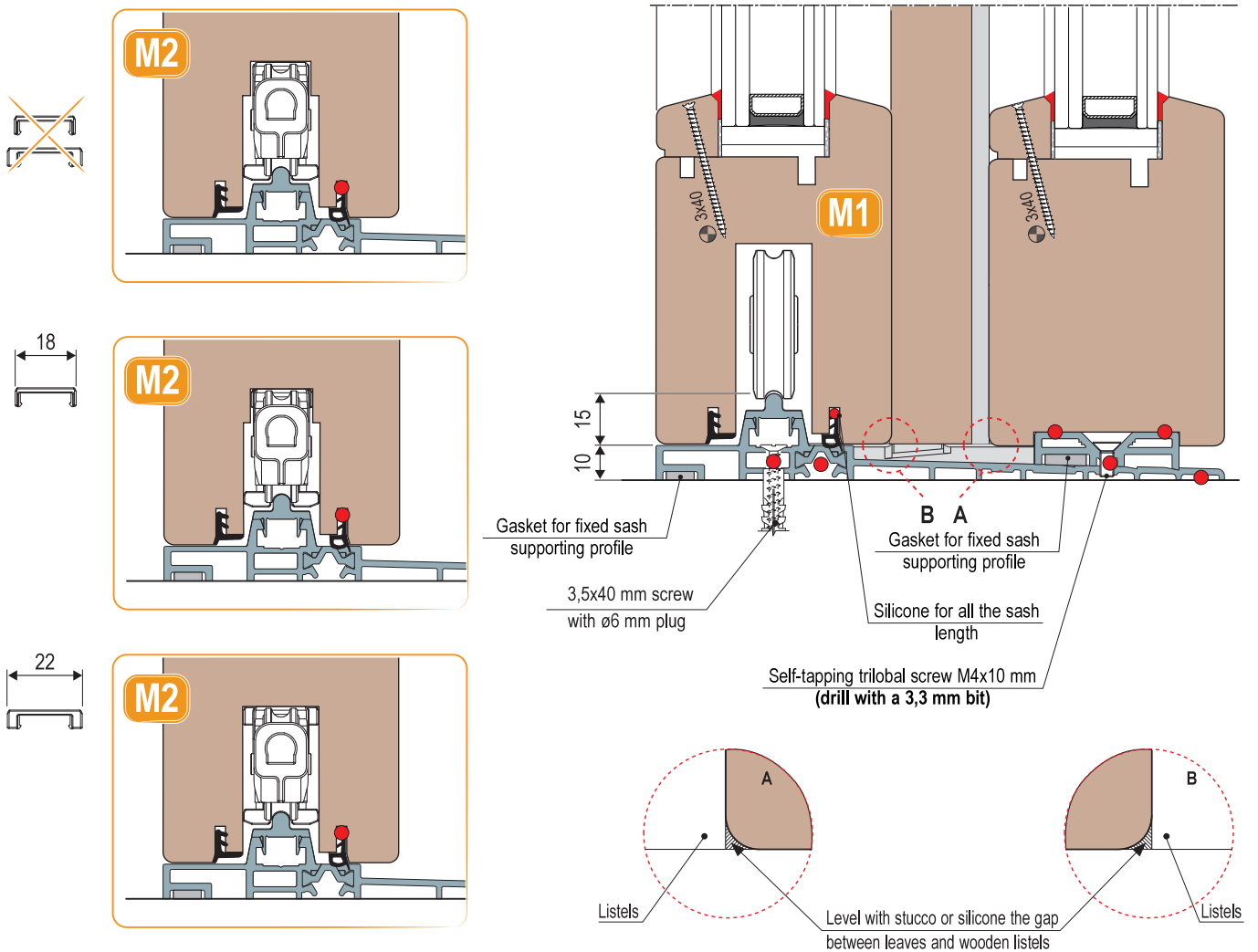

**Millings - Vertical section, upper point**

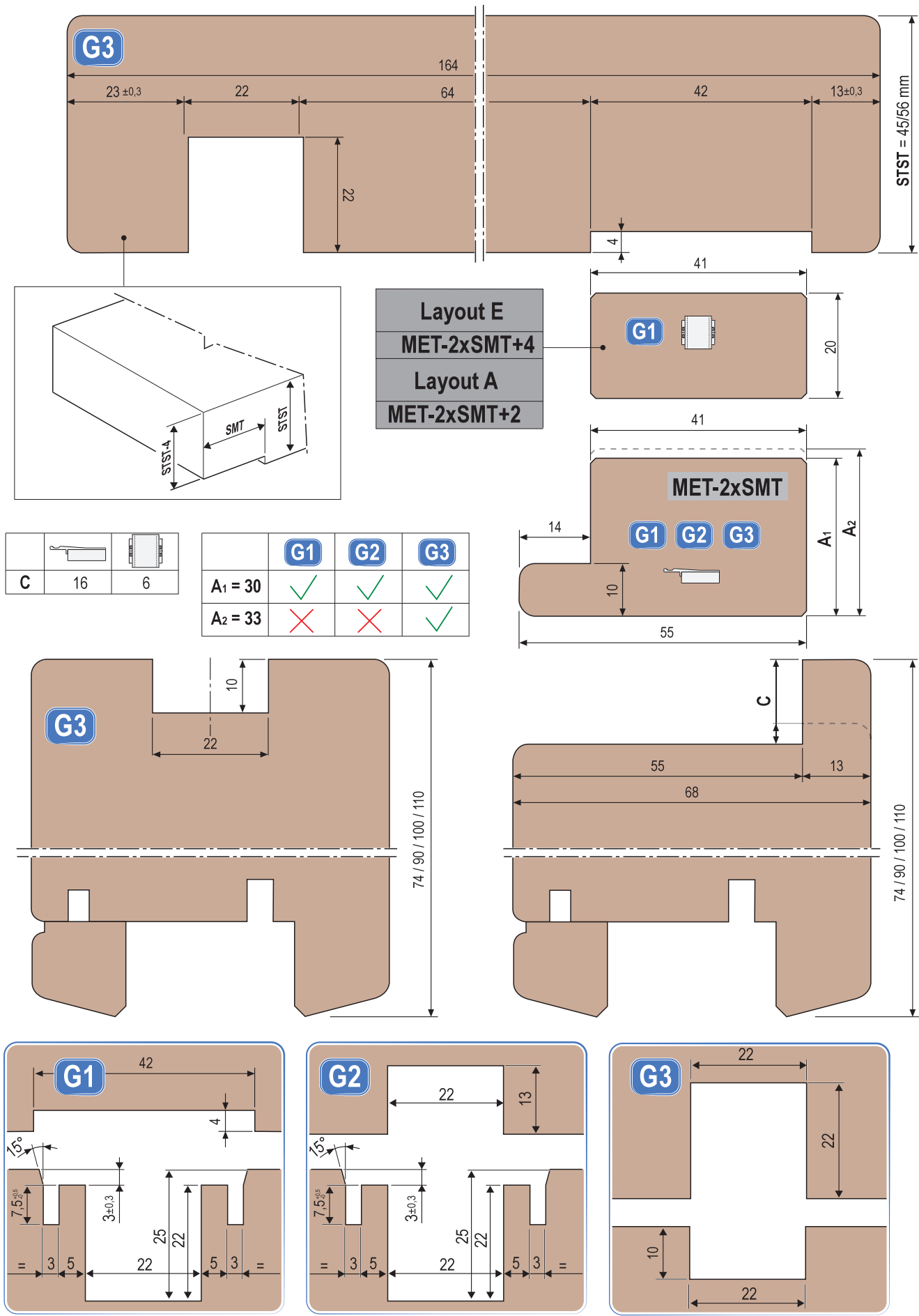

**Millings - Vertical section, lower point**



It is possible to realise a lower transom height included between 74 and 90 mm; in this case, it is necessary to use XC S-Line carriages with lower transom between 90 and 110 mm. It is possible to use both carriages.

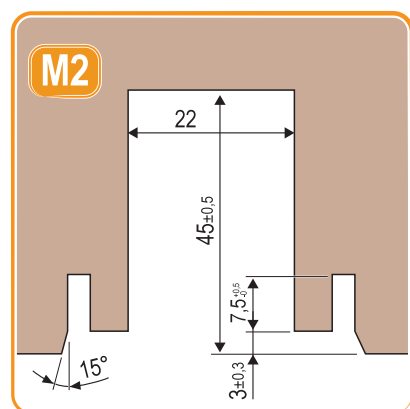
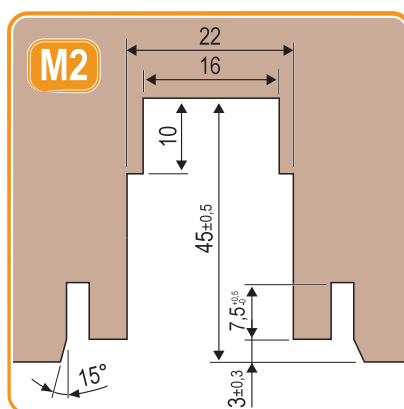
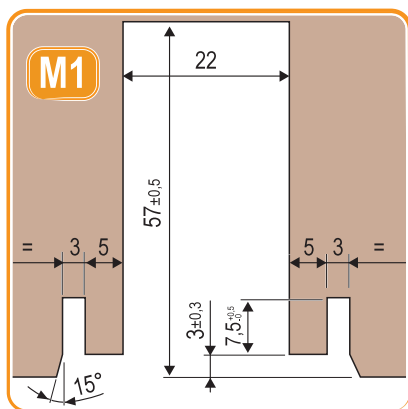
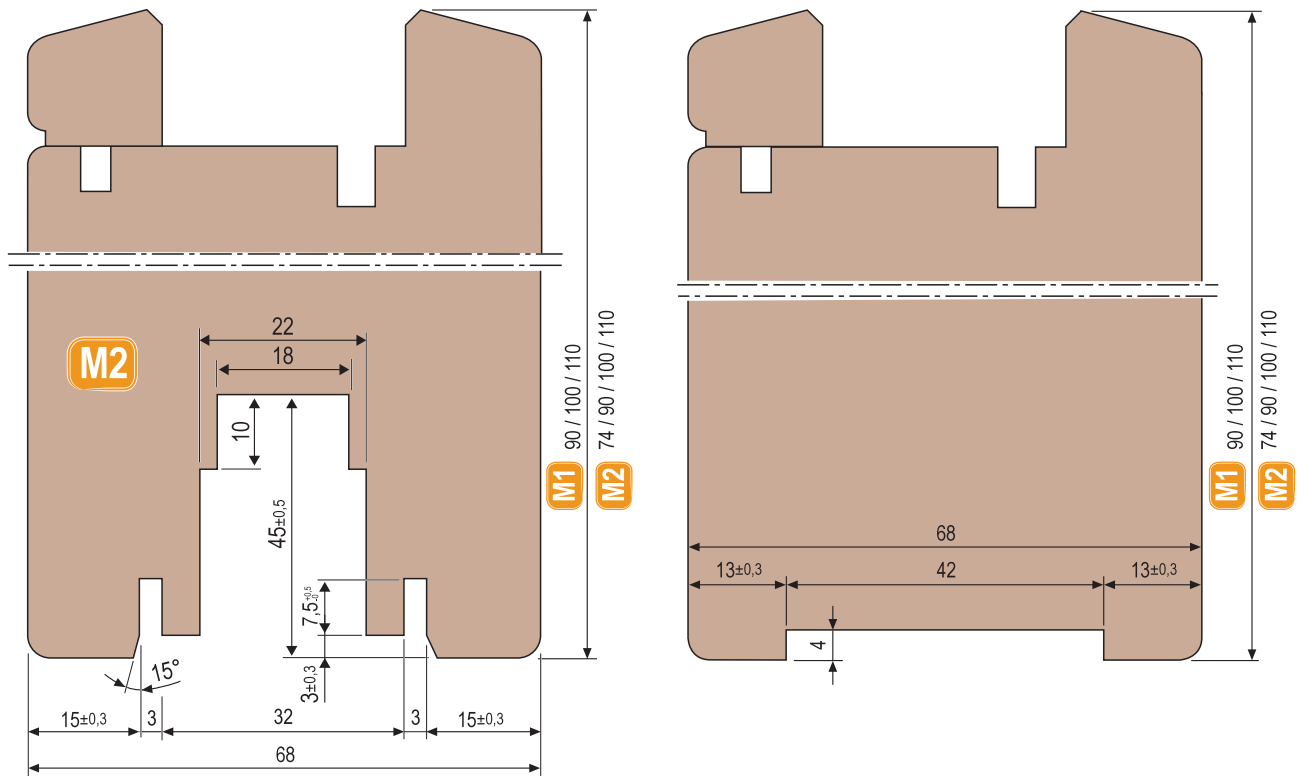

**Millings - Sliding sash horizontal section**

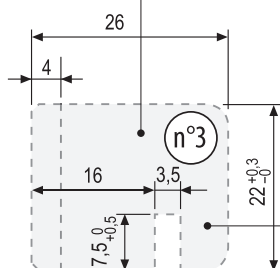
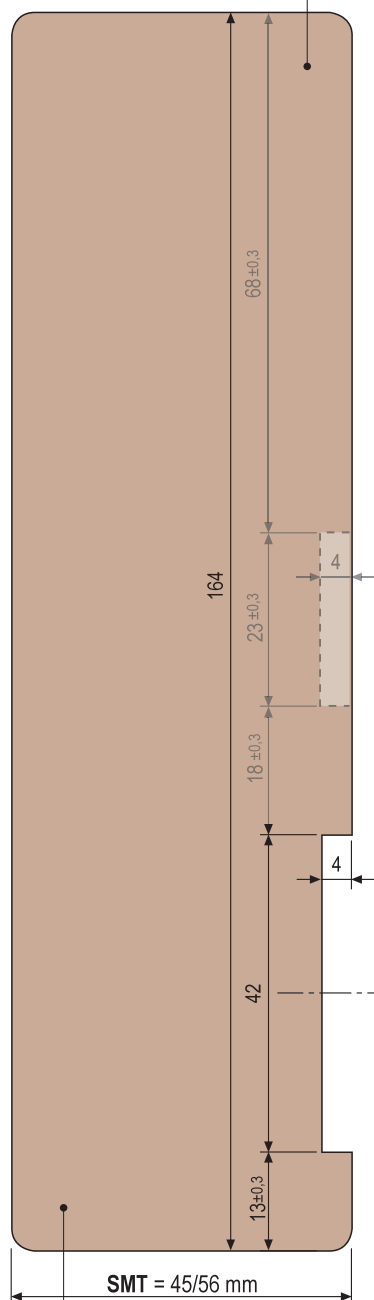
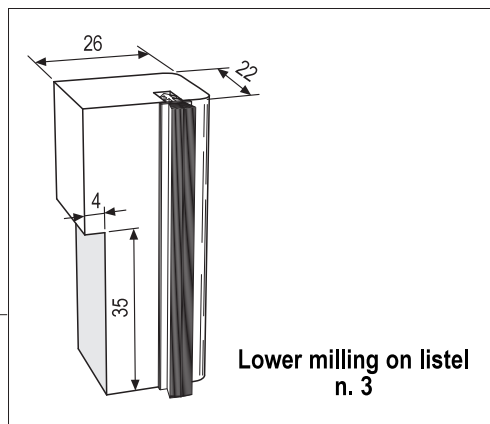
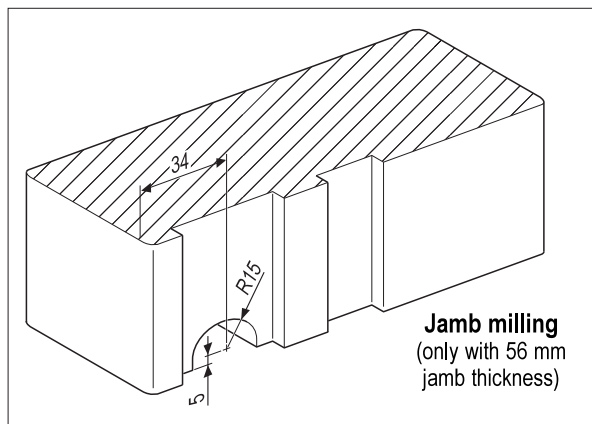

|             |                   |                    |
|-------------|-------------------|--------------------|
|             |                   |                    |
| Aria/Gap 12 | <b>HET-STST-6</b> | <b>HET-STST-22</b> |
| Aria/Gap 15 | -                 | <b>HET-STST-25</b> |

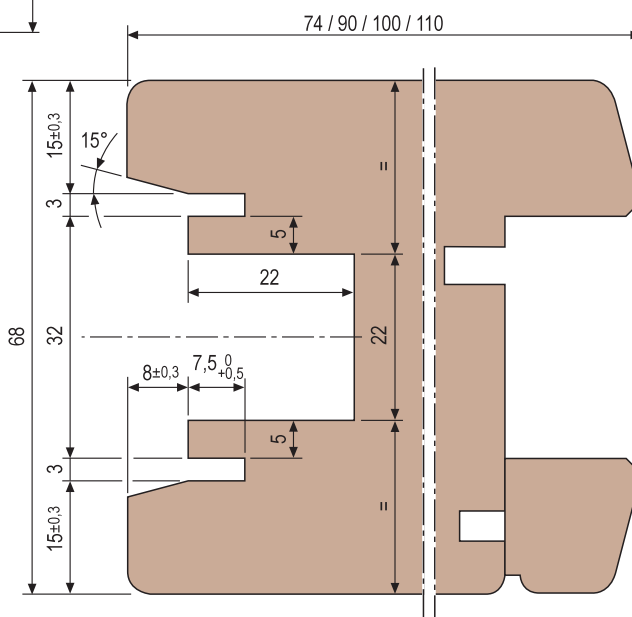
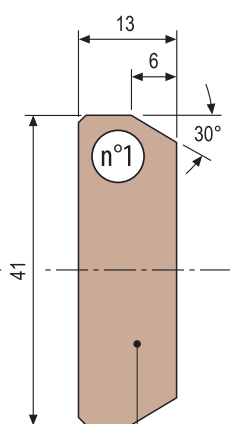

|               |                    |
|---------------|--------------------|
| <b>SMT=56</b> | <b>HET-STST-6</b>  |
| <b>SMT=45</b> | <b>HET-STST-24</b> |

|                    |                    |                    |
|--------------------|--------------------|--------------------|
| <b>G1</b>          | <b>G2</b>          | <b>G3</b>          |
| <b>HET-STST-57</b> | <b>HET-STST-40</b> | <b>HET-STST-47</b> |

**Millings - Fixed sash horizontal section**

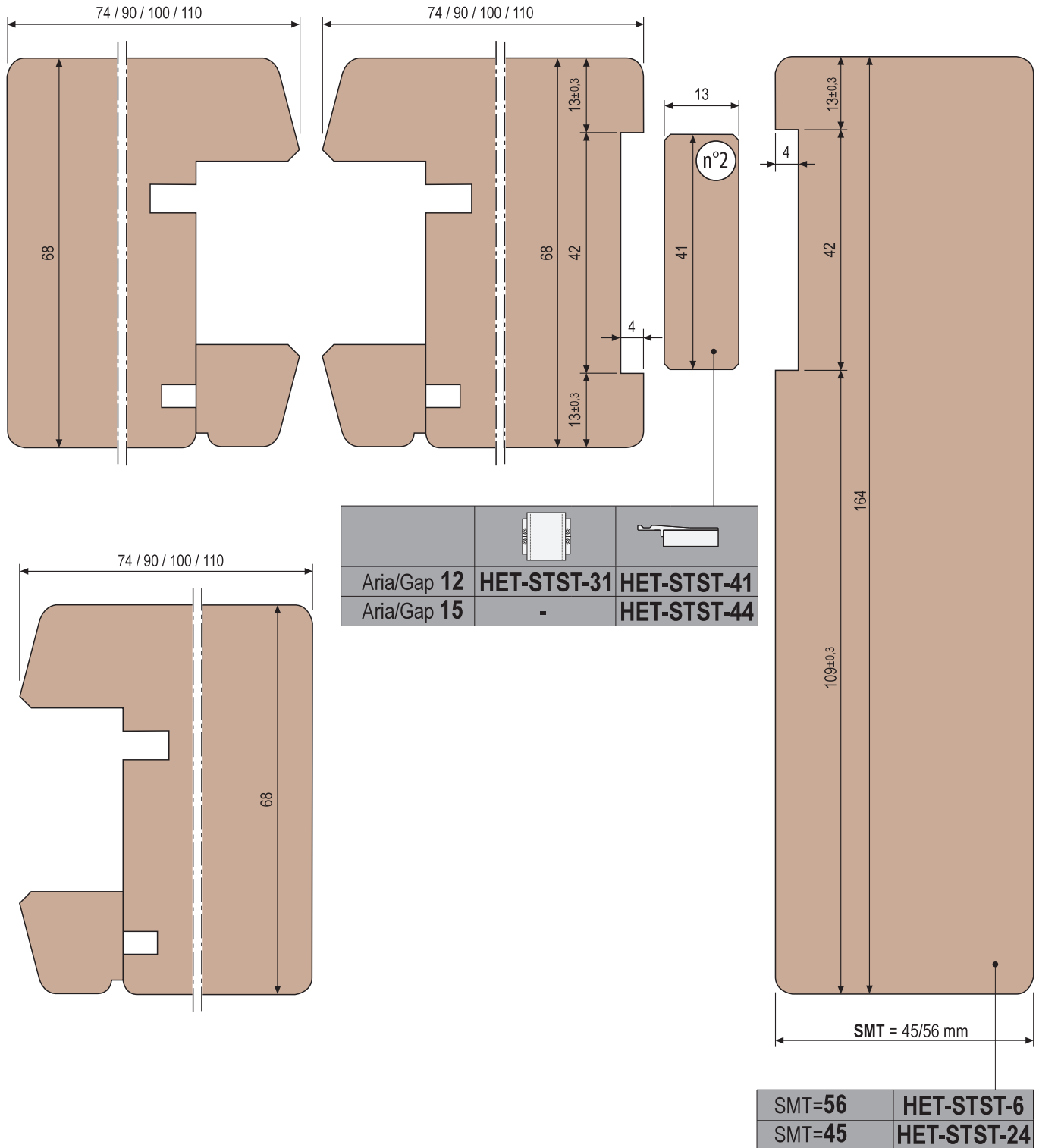

Millings - Central point horizontal section

**Uni-V**

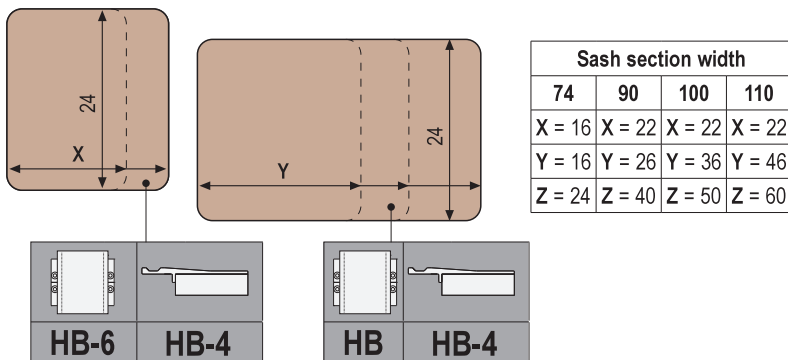

**Uni-V Mini**

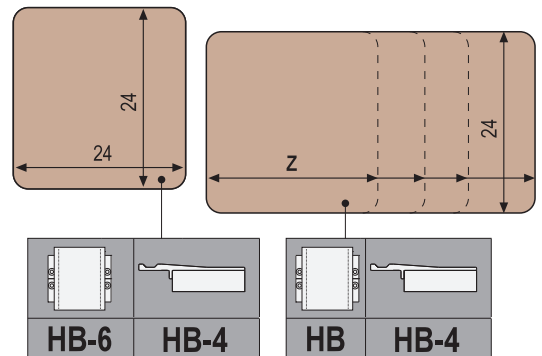

**Easy**

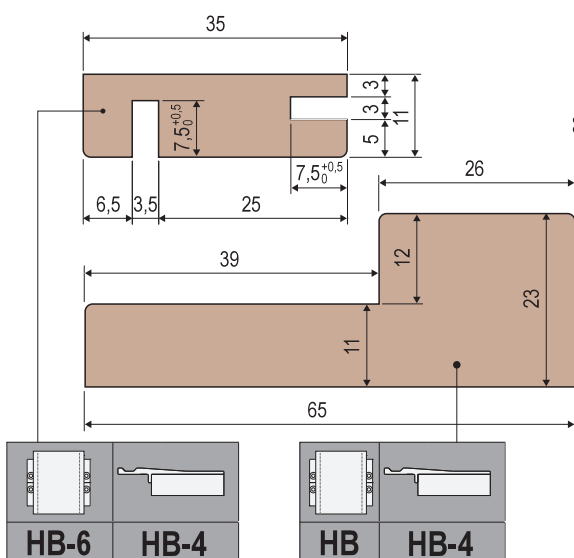

**Basic**

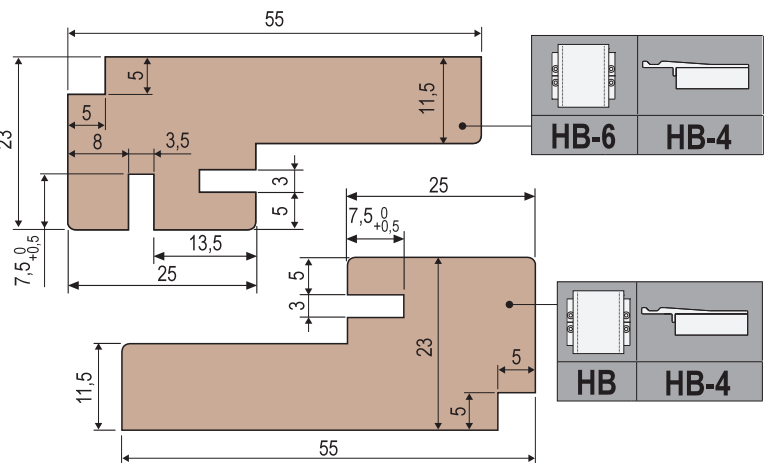



**Millings - Central point horizontal section for coaxial sashes**

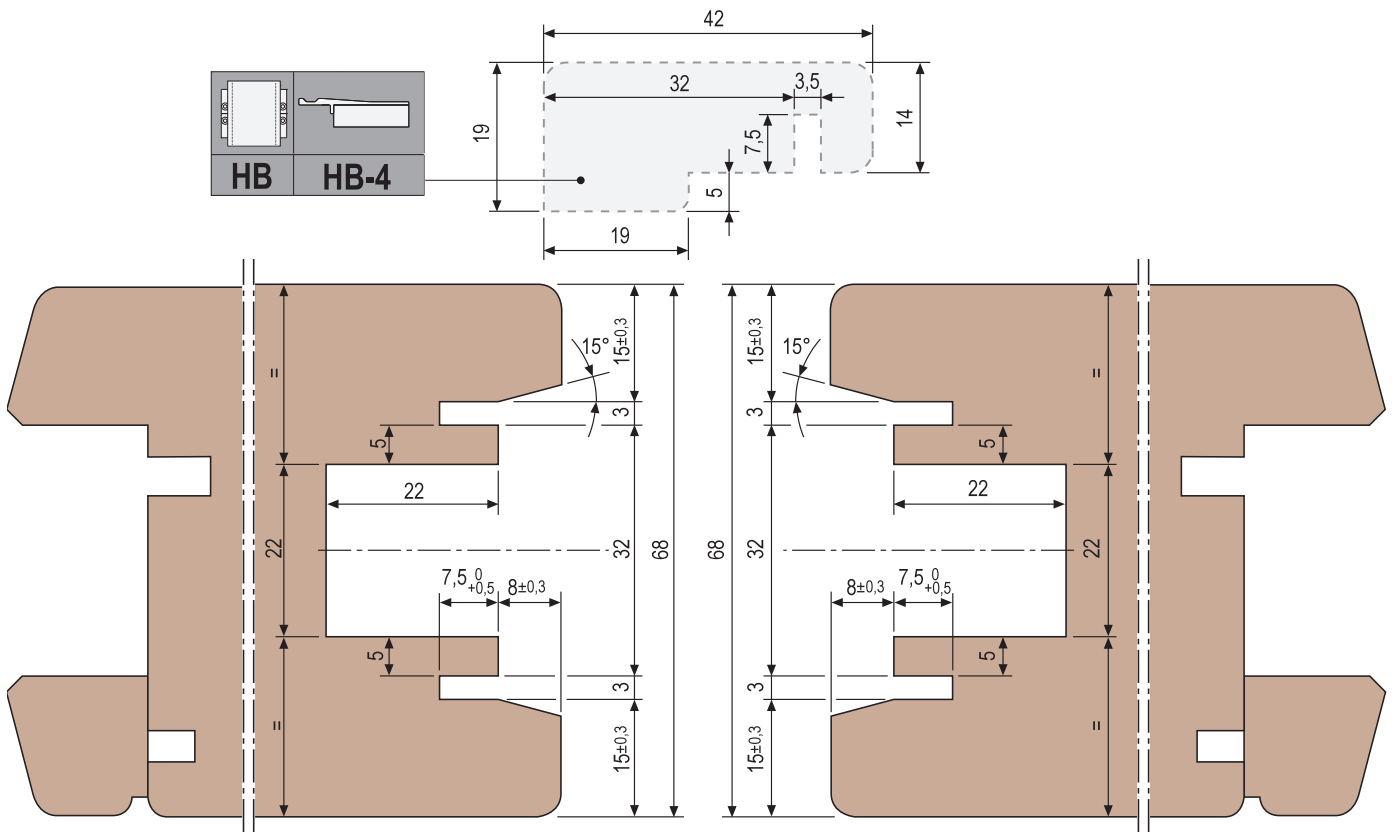

Formulas of components cut

|  |           | LAYOUT A    |             |             | LAYOUT E              |             |             |
|--|-----------|-------------|-------------|-------------|-----------------------|-------------|-------------|
|  |           |             |             |             |                       |             |             |
|  |           |             |             |             |                       |             |             |
|  | XC        | HB-94       | HB-94       | HB-99       | HB-94                 | HB-94       | HB-99       |
|  | XC S-Line |             |             |             |                       |             |             |
|  | XC        |             |             |             |                       |             |             |
|  | XC S-Line |             |             |             |                       |             |             |
|  | XC        |             |             |             |                       |             |             |
|  | XC S-Line |             |             |             |                       |             |             |
|  |           | -           | MET-2xSMT-2 | -           | -                     | MET-2xSMT-2 | -           |
|  |           | -           | -           | MET-2xSMT-2 | -                     | -           | MET-2xSMT-2 |
|  |           | MET-2xSMT-2 | -           | -           | MET-2xSMT-2           | -           | -           |
|  |           | HET-STST-57 | HET-STST-47 | HET-STST-40 | -                     | -           | -           |
|  |           | HB-75       | HB-28       | HB-28       | HB-75                 | HB-28       | HB-28       |
|  |           | LB          |             |             | 2 (pieces)<br>LB LB+4 |             |             |
|  |           | MET         |             |             | MET                   |             |             |
|  |           | LBF+9       |             |             | LBF+9                 |             |             |
|  |           | MET-2xSMT-2 |             |             | MET-2xSMT-2           |             |             |

|  |       |
|--|-------|
|  |       |
|  | HB-10 |
|  | HB-14 |
|  | HB-4  |
|  | HB-16 |
|  | HB-14 |

## LAYOUTS B & F

- Sash with only one bottom rail with the possibility for a baseboard.
- Vertical - bottom internal and external gasket: balloon gasket with vulcanized EPDM corner.
- PVC top gasket with fin.
- Water, air, wind, and soft body impact tests conducted with glass: 44.1/15/33.1 (minimum usable).
- Layout F constructed with symmetric central point with aluminium pin holder and end caps for closing the openings.

### Dimensions calculation of sliding sashes

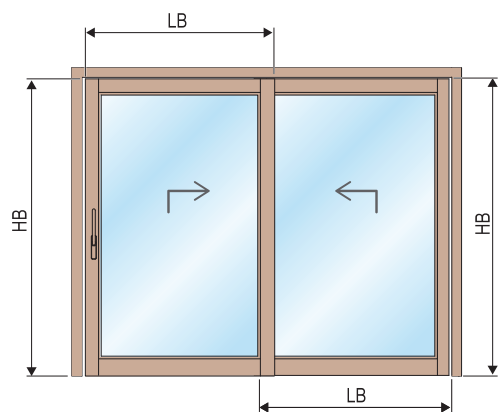

$$HB = HET - (STST + 27 + 10)$$

(Tolerance HB ± 0,5)

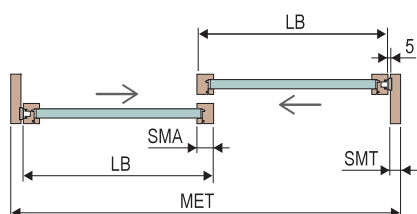
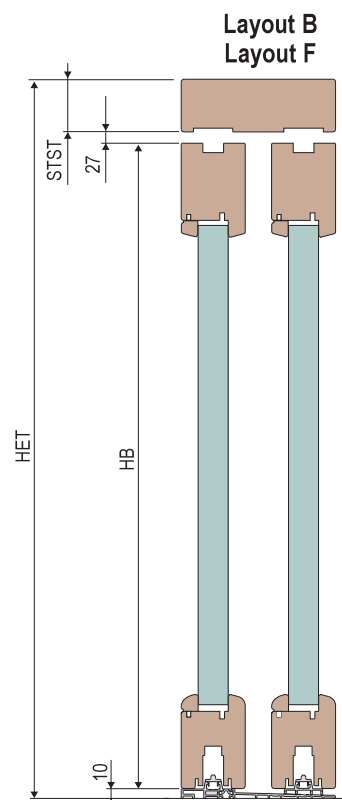

**Layout B**  
2 sliding sashes  
 $LB = [MET - 2 \times (SMT + 5)] : 2 + SMA : 2$



**Layout F**  
4 sliding sashes  
 $LB = [MET - 15 (2 \times SMT)] : 4 + SMA : 2$



The indications in this section refer to lift-and-slide assemblies with top guide. However, scheme B lift-and-slide assemblies can be constructed with reduced top guide. In this case, refer to the specifications in the section dedicated to schemes A-E.



Since this section of the manual includes only the work and indications that set a B-F scheme apart from an A-E scheme, for omitted information, refer to the section dedicated to A-E schemes.

**Hardware diagram with hooks lock****1 Hooks lock**

G039EE.03.XX HB=1775-2150 Handle H = 1000  
 G039EE.04.XX HB=1925-2400 Handle H = 1000  
 G039EE.05.XX HB=2325-2750 Handle H = 1000

**2 Additional hook kit - G05008.00.00****3 Microventil. additional hook kit - G05010.00.00****4 Second sash hooks lock**

GR39EE.03.01 HB=1775-2150 Handle H = 1000  
 GR39EE.04.01 HB=1925-2400 Handle H = 1000  
 GR39EE.05.01 HB=2325-2750 Handle H = 1000

**5 Hooks extension 500 mm - G04600.01.01****6 Covering profile 1000 mm - G04401.02.01****7 Gas spring kit - GMG702.04.00****8 XC basic carriages kit - G04104.00.00****9 XC suppl. carriages kit - G04108.00.00****10 XC S-Line carriages kit - G04109.00.00****11 XC S-Line suppl. carriages kit - G04110.00.00****12 Carriages connecting rod**

G04601.00.01 L=1000 G04601.00.03 L=1800  
 G04601.00.02 L=1400 G04601.00.04 L=2700

**13 Handle fastening plate**

G05371.M5.00 hole M5  
 G05371.M6.00 hole M6

**14 Anti-burglar plate kit - G05004.00.00****15 Sensors**

G05006.00.86 Grey  
 G05006.00.93 Black  
 G05003.00.00 Clip

**16 Lateral locking profile for hooks lock**

G01359.03.XX GR3 Predisposit. 2 hooks  
 G01359.04.XX GR4 Predisposit. 2 hooks  
 G01359.05.XX GR5 Predisposit. 2 hooks  
 G01359.13.XX GR3 Predisposit. 3 hooks  
 G01359.14.XX GR4 Predisposit. 3 hooks  
 G01359.15.XX GR5 Predisposit. 3 hooks  
 G01359.23.XX GR3 Predis. signal system  
 G01359.24.XX GR4 Predis. signal system  
 G01359.25.XX GR5 Predis. signal system

**17 Extension for lock.prof. for hooks lock**

G01360.01.XX L=500

**18 Coax. sashes lock. prof. for hooks lock + caps**

G01373.13.XX L=2075 HB=1775-2150 with hooks strik.  
 G01373.14.XX L=2325 HB=1925-2400 with hooks strik.  
 G01373.15.XX L=2750 HB=2325-2750 with hooks strik.

**19 Extens. lock.prof. coax sashes for hooks, 500 mm**

G01364.01.XX with hooks striker

**20 Striker for lock hook - G06201.00.XX****21 Strik. for hook lock with signal syst. - G06203.00.XX****22 Central pad and caps kit - Easy and Uni-V**

G0028B.00.93

**23 Shaped cap for upper guide (F)****24 2 mm adapter (F)****25 Terminal cap for lock (F)****26 Rear upper covering cap (F)****27 Rear lower covering cap (F)****28 Door stop**

G00204.00.91 White G00204.00.93 Black  
 G00204.00.86 Grey

**29 Uni-V central point kit**

G02208.25.KK L=2500  
 G02208.31.KK L=3100  
 G02208.40.KK L=4000

**30 Uni-V central point caps kit**

G01610.DX.93 Right  
 G01610.SX.93 Left

**31 Uni-V Mini central point kit**

G02211.25.KK L=2500 G02211.40.KK L=4000  
 G02211.31.KK L=3100

**32 Uni-V Mini central point caps kit**

G01623.DX.93 right G01623.SX.93 left

**33 Low threshold with thermal cut**

G01741.01.XX L=3000  
 G01741.02.XX L=4000  
 G01741.03.XX L=5000  
 G01741.04.XX L=6000

**34 Rail for second sliding sash for low threshold**

G01743.01.XX L=3000  
 G01743.02.XX L=4000  
 G01743.03.XX L=5000  
 G01743.04.XX L=6000

**35 Snap-in rail**

G02739.01.XX L=3000  
 G02739.02.XX L=4000  
 G02739.03.XX L=5000  
 G02739.04.XX L=6000

**36 Top guide**

G00734.01.XX L=3000  
 G00734.02.XX L=4000  
 G00734.03.XX L=6000

**37 Expanded PVC gasket for rails**

G00733.06.00

**38 Fixed sash supp. prof. for low threshold**

G01742.01.00 L=1500  
 G01742.02.00 L=2000  
 G01742.03.00 L=2500  
 G01742.04.00 L=3000

**39 Fastening basic kit - G01728.00.27****40 Compensator caps kit for 45 jamb**

G01432.DX.JJ layout B right  
 G01432.SX.JJ layout B left  
 G01432.00.JJ layout F

**41 External side gasket (balloon)**

G020DX.09.93 - G020SX.09.93 L1500 x H2500  
 G02000.08.93 L3000 x H3000

**42 PVC upper flexible gasket**

G00733.02.01 L=40  
 G00733.02.02 L=200

**43 Flexible gasket for central point**

G00733.01.01 L=40 G00733.04.01 L=40  
 G00733.01.02 L=200 G00733.04.02 L=200

**44 Brush for decompression chamber**

G02002.16.00 L=1600 G02002.31.00 L=3100  
 G02002.25.00 L=2500 G02002.31.20 L=3100 (tube)  
 G02002.25.20 L=2500 (tube)

**45 Upper terminal pad for high guide**

G01413.27.96 96 mm

**46 Brush up. term. pad - G00728.12.15****47 Adapter for brush pad - G00728.27.00****48 EPDM gasket - G01416.17.15****49 XC anti-derailed device - G01611.02.00****50 Rod guide - G05102.00.00****51 S-Line anti-derailed device - G01611.01.00****52 S-Line rod guide - G05104.00.00****53 Connecting kit jamb-transom - G00728.00.23****54 Handle****(F) Caps kit for universal upper guide**

G00203.01.JJ high rail

XX = 01 Alu. silver KK = 01 Silver  
 02 Alum. electrocolour 93 Black

EE = 27 Backset 27,5 JJ = 86 Grey RAL 7035  
 37 Backset 37,5 93 Black

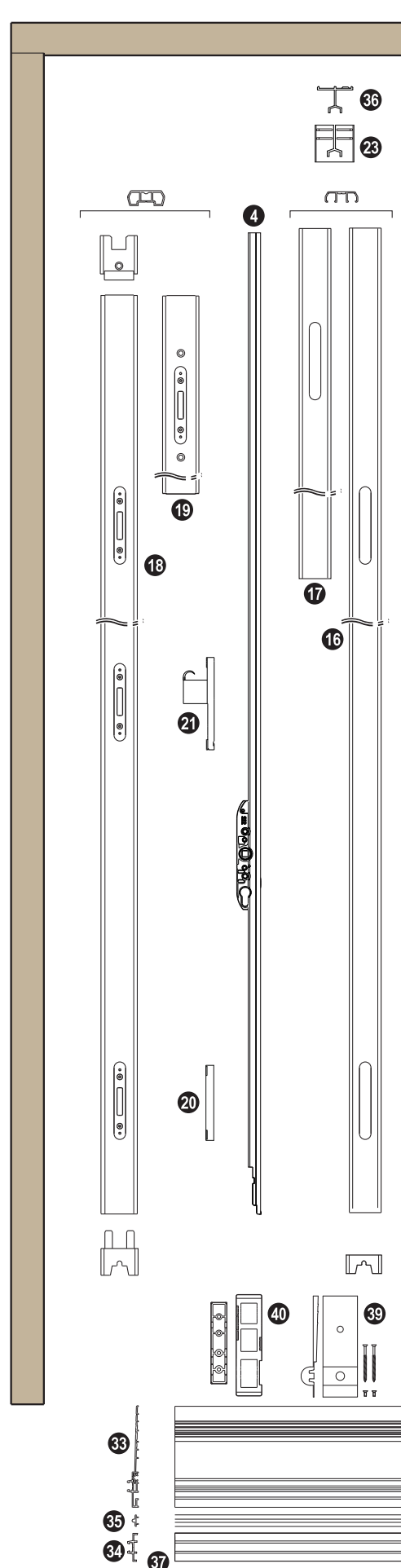

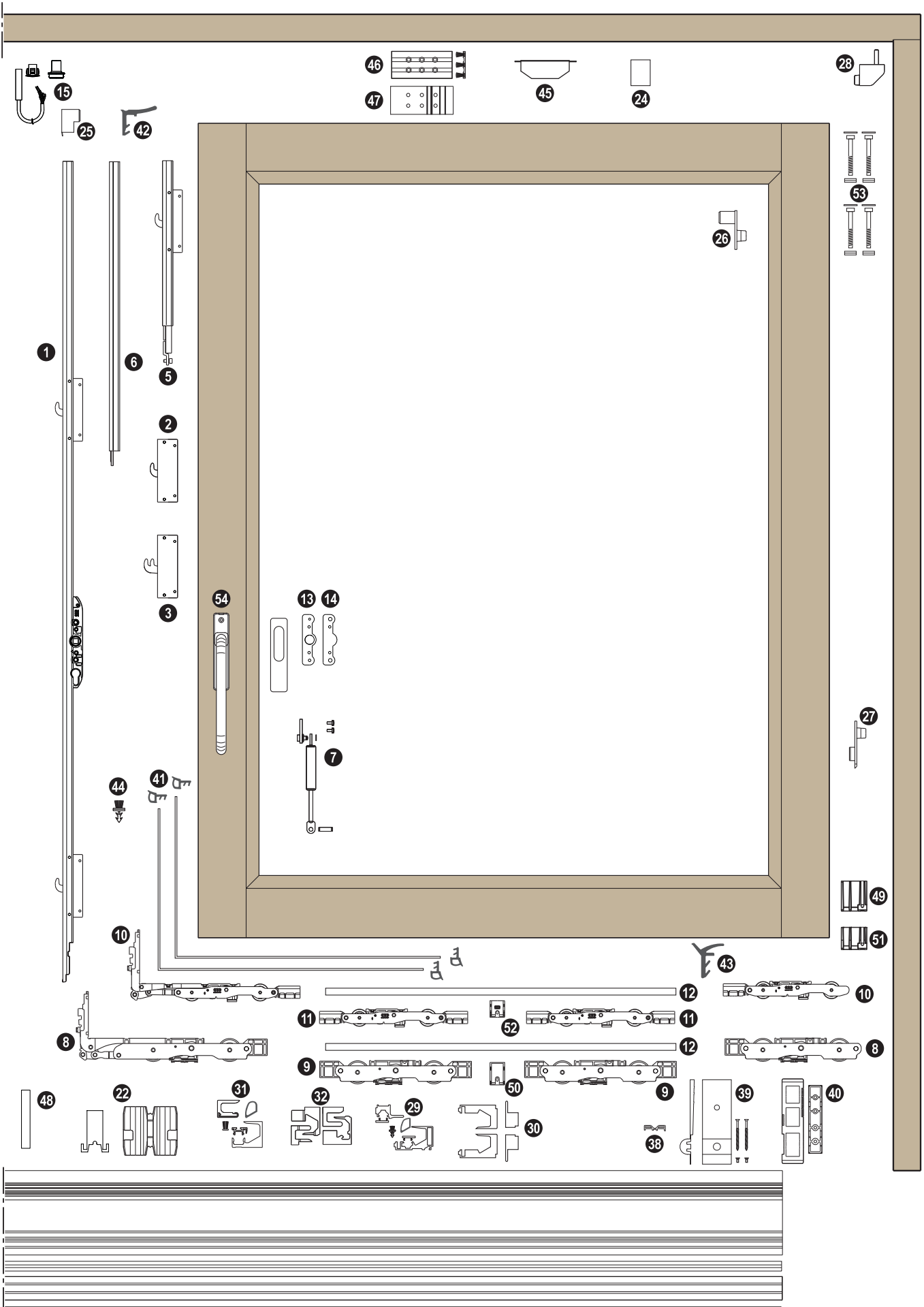

**Hardware diagram with pins lock**

- 1 Pins lock**  
G040EE.01.XX Handle H = 400 HB=800-1200  
G040EE.02.XX Handle H = 400 HB=1170-1800  
G040EE.03.XX Handle H = 1000 HB=1770-2150  
G040EE.04.XX Handle H = 1000 HB=1920-2400  
G040EE.05.XX Handle H = 1000 HB=2401-2750
- 2 Pins extension 500 mm** - G04401.01.01
- 3 Covering profile 1000 mm** - G04401.02.01
- 4 Gas spring kit** - GMG702.04.00
- 5 XC basic carriages kit** - G04104.00.00
- 6 XC suppl. carriages kit** - G04108.00.00
- 7 XC S-Line carriages kit** - G04109.00.00
- 8 XC S-Line supp. carriages kit** - G04110.00.00
- 9 Carriages connecting rod**  
G04601.00.01 L=1000 G04601.00.03 L=1800  
G04601.00.02 L=1400 G04601.00.04 L=2700
- 10 Handle fastening plate**  
G05371.M5.00 hole M5  
G05371.M6.00 hole M6
- 11 Anti-burglar plate kit** - G05004.00.00
- 12 Sensors**  
G05006.00.86 Grey  
G05006.00.93 Black  
G05003.00.00 Clip
- 13 Pin holder profile for lateral point**  
G01341.00.XX L=1800 HB=800-1800  
G01341.01.XX L=2900 HB=1770-2900  
G01341.02.XX L=2900 HB=2401-2900
- 14 Lock. prof. for coaxial sashes + caps**  
G01361.01.XX L=1125 HB=810-1200  
G01361.02.XX L=1725 HB=1175-1800  
G01361.03.XX L=2075 HB=1775-2150 with caps  
G01361.04.XX L=2325 HB=1925-2400  
G01361.05.XX L=2750 HB=2325-2750  
  
G01340.01.XX L=1125 HB=810-1200  
G01340.02.XX L=1725 HB=1175-1800 with caps and  
G01340.03.XX L=2075 HB=1775-2150 ventilation pin  
G01340.04.XX L=2325 HB=1925-2400  
G01340.05.XX L=2750 HB=2325-2750
- 15 Coax. sashes lock. prof. extens. for pins, 500 mm**  
G01361.97.XX
- 16 Coax. sashes lock. prof. extens. for pins, 1000 mm**  
G01757.00.XX
- 17 Pin**  
G40728.00.03 for closing  
G04902.01.00 for ventilation  
G40728.00.33 for anti-burglar closing
- 18 Central pad and caps kit** - Easy and Uni-V  
G0028B.00.93
- 19 Shaped cap for upper guide** (F)
- 20 2 mm adapter** (F)
- 21 Terminal cap for lock** (F)
- 22 Rear upper covering cap** (F)
- 23 Rear lower covering cap** (F)
- 24 Door stop**  
G00204.00.91 White G00204.00.93 Black  
G00204.00.86 Grey
- 25 Uni-V central point kit**  
G02208.25.KK L=2500  
G02208.31.KK L=3100  
G02208.40.KK L=4000
- 26 Uni-V central point caps kit**  
G01610.DX.93 right  
G01610.SX.93 left
- 27 Uni-V Mini central point kit**  
G02211.25.KK L=2500 G02211.40.KK L=4000  
G02211.31.KK L=3100
- 28 Uni-V Mini central point caps kit**  
G01623.DX.93 Right G01623.SX.93 Left

- 29 Low threshold with thermal cut**  
G01741.01.XX L=3000  
G01741.02.XX L=4000  
G01741.03.XX L=5000  
G01741.04.XX L=6000
- 30 Rail for second sliding sash for low threshold**  
G01743.01.XX L=3000  
G01743.02.XX L=4000  
G01743.03.XX L=5000  
G01743.04.XX L=6000
- 31 Snap-in rail**  
G02739.01.XX L=3000  
G02739.02.XX L=4000  
G02739.03.XX L=5000  
G02739.04.XX L=6000
- 32 Upper guide**  
G00734.01.XX L=3000  
G00734.02.XX L=4000  
G00734.03.XX L=6000
- 33 Expanded PVC gasket for rails**  
G00733.06.00
- 34 Fixed sash supp. profile for low threshold**  
G01742.01.00 L=1500  
G01742.02.00 L=2000  
G01742.03.00 L=2500  
G01742.04.00 L=3000
- 35 Basic fastening kit** - G01728.00.27
- 36 Compensator caps kit for 45 jamb**  
G01432.DX.JJ layout B right  
G01432.SX.JJ layout B left  
G01432.00.JJ layout F
- 37 External side gasket (ballon)**  
G020DX.09.93 - G020SX.09.93 L1500 x H2500  
G02000.08.93 L3000 x H3000
- 38 PVC upper flexible gasket**  
G00733.02.01 L=40  
G00733.02.02 L=200
- 39 Flexible gasket for central point**  
G00733.04.01 L=40  
G00733.04.02 L=200
- 40 Brush for decompression chamber**  
G02002.16.00 L=1600 G02002.31.00 L=3100  
G02002.25.00 L=2500 G02002.31.20 L=3100 (tube)  
G02002.25.20 L=2500 (tube)
- 41 Upper thermal pad for high guide**  
G01413.27.96 96 mm
- 42 Pad for brush up. terminal** - G00728.12.15
- 43 Adapter for brush pad** - G00728.27.00
- 44 EPDM gasket** - G01416.17.15
- 45 Standard carriages anti-derailed device** - G01611.00.00
- 46 XC anti-derailed device** - G01611.02.00
- 47 Rod guide** - G05102.00.00
- 48 S-Line anti-derailed device** - G01611.01.00
- 49 S-Line rod guide** - G05104.00.00
- 50 Connect. kit jamb - transom** - G00728.00.23
- 51 Handle**

(F) Caps kit for universal top guide  
G00203.01.JJ High rail

XX = 01 Alu. silver      KK = 01 Silver  
         02 Alum. electroclour      93 Black  
  
EE = 27 Backset 27,5  
         37 Backset 37,5

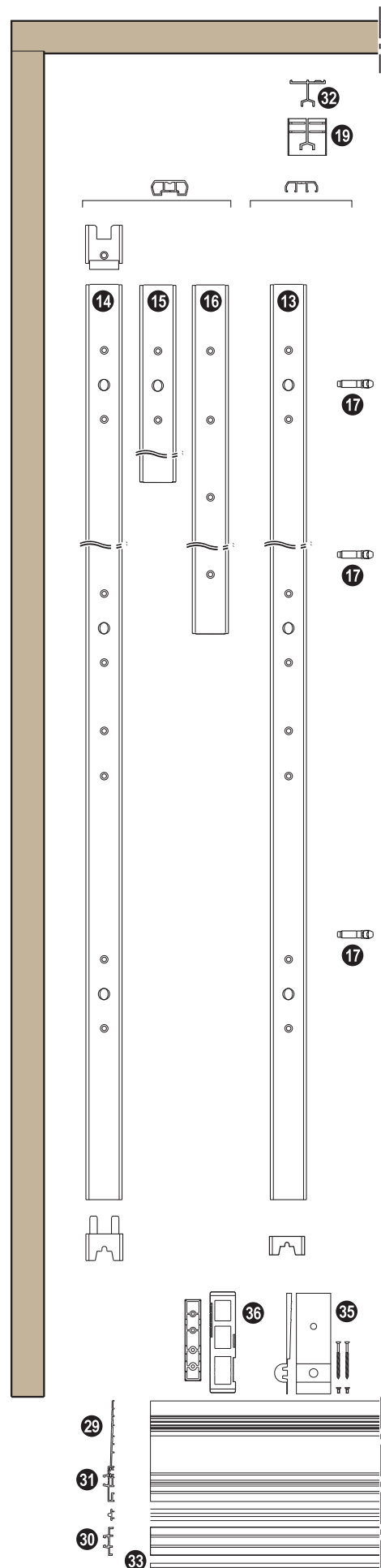

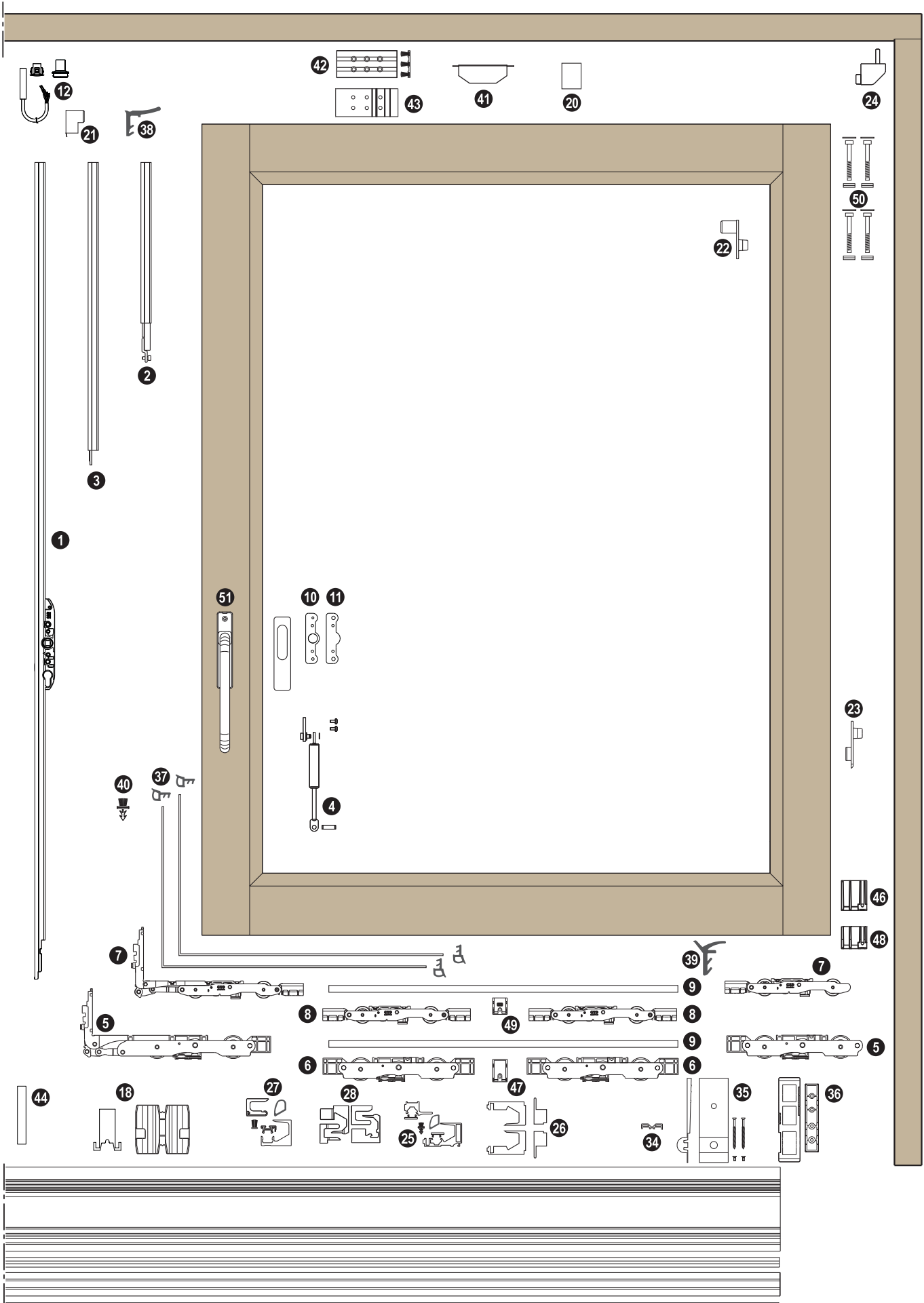

Horizontal section

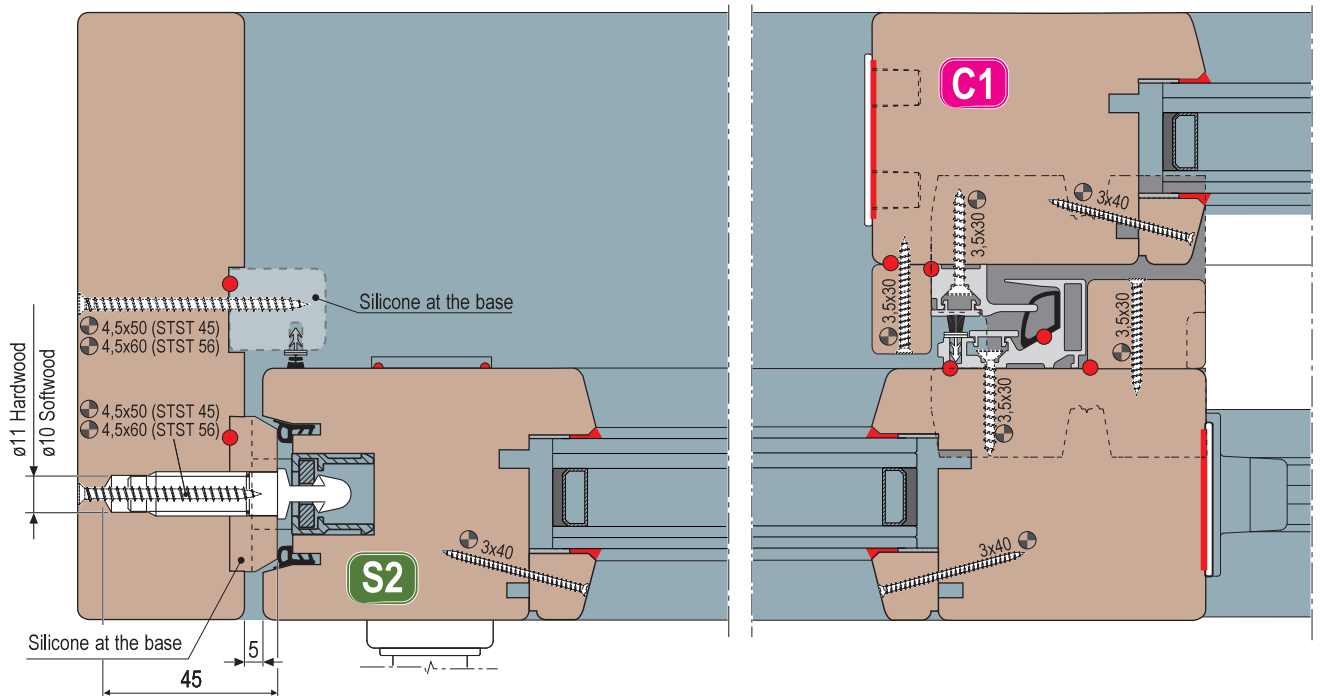

PINS LOCK

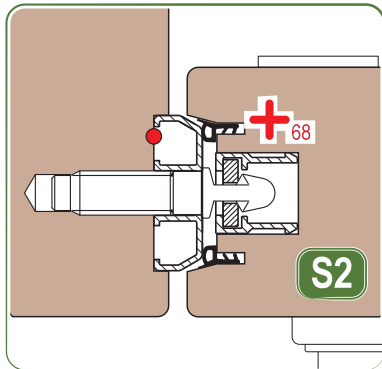

HOOKS LOCK

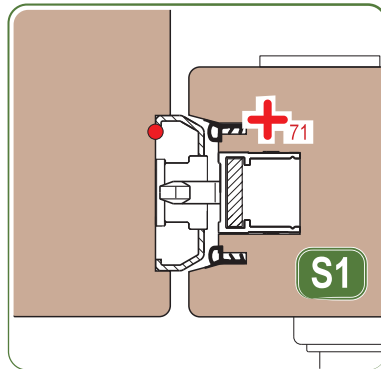

HOOKS LOCK

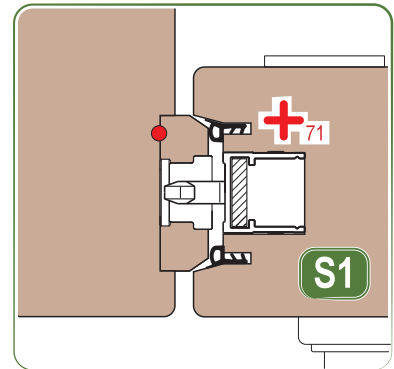

COAXIAL SASHES CENTRAL POINT  
(with pins lock)

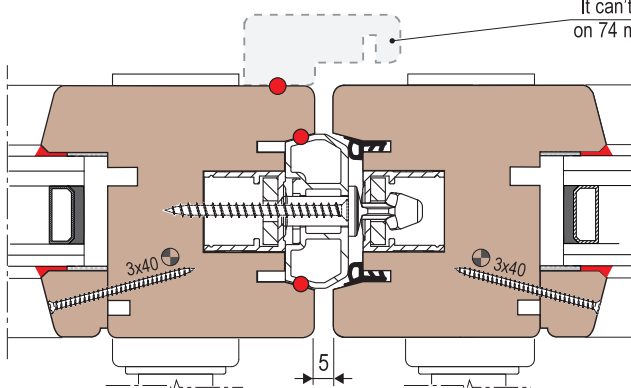

COAXIAL SASHES CENTRAL POINT  
(with hooks lock)

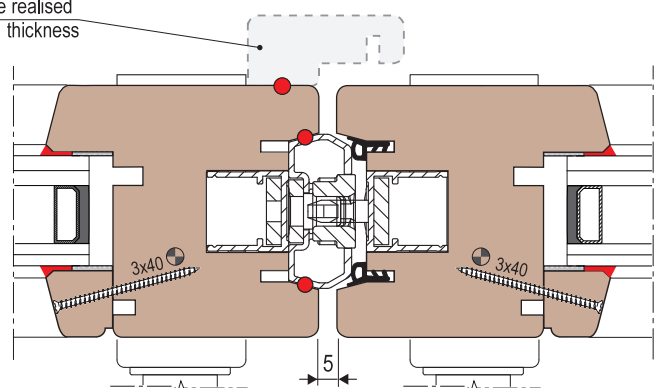

It can't be realised  
on 74 mm thickness



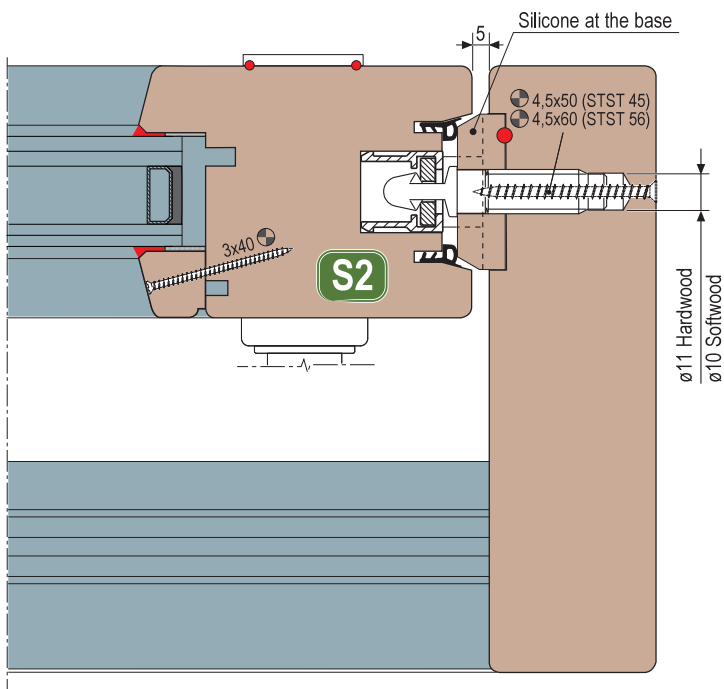

**Uni-V**

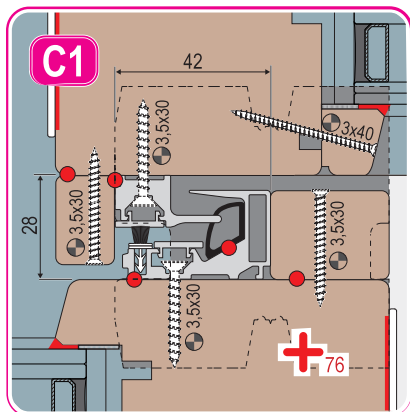

Position the pad as indicated

**Base**

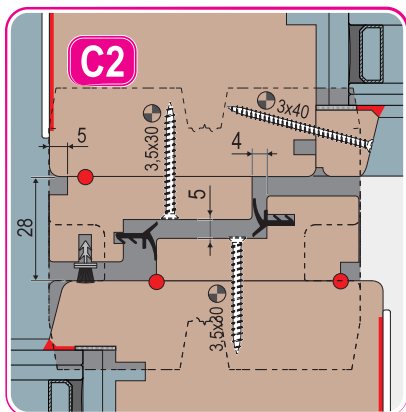

Align the pad to the external sash jamb

|                        | <b>Uni-V</b> | <b>Uni-V Mini</b> |
|------------------------|--------------|-------------------|
| Sash section width 74  | X = 26       | X = 26            |
| Sash section width 90  | X = 10       | X = 10            |
| Sash section width 100 | X = 6        | -                 |
| Sash section width 110 | -            | -                 |

**Easy**

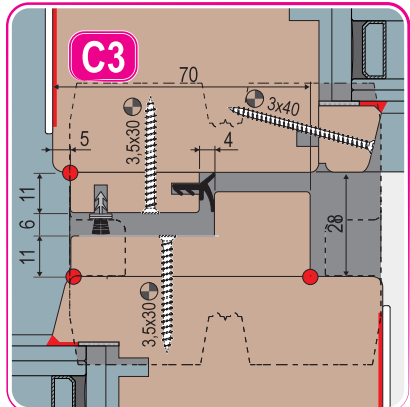

Position the pad as indicated

**Uni-V Mini**

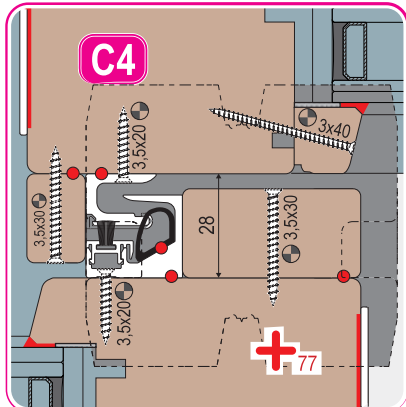

Position the pad as indicated

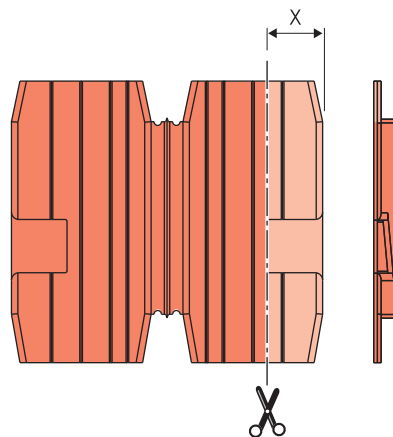

Construction details of jambs and listels

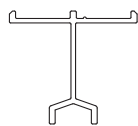

CAP CUT DETAIL

LISTEL N.1 WITH LOW RAIL

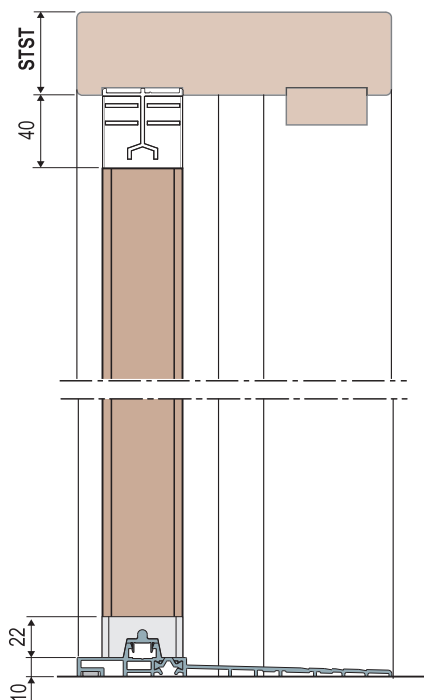

Upper point vertical section

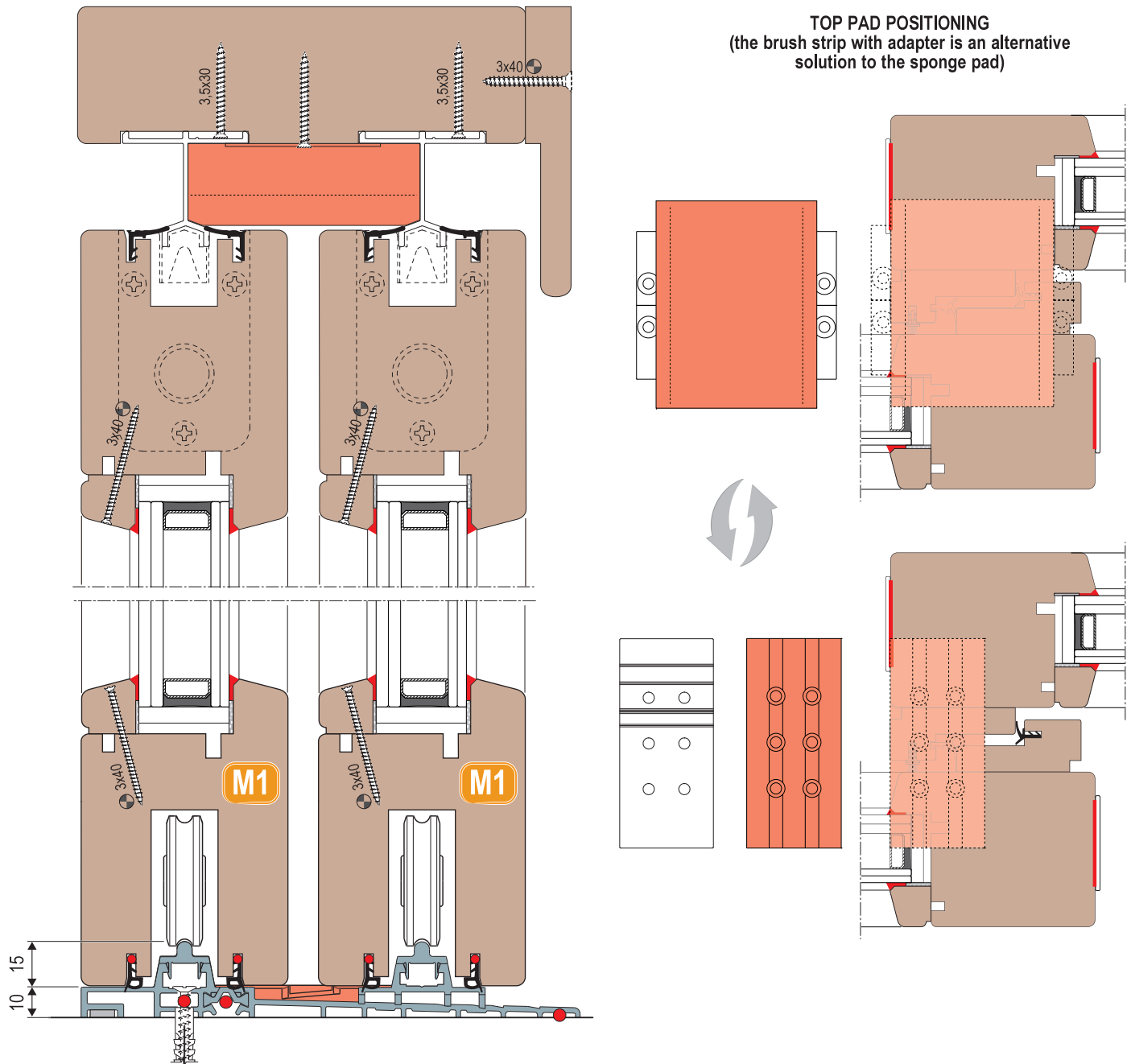

XC S-LINE CARRIAGES  
(SEAT 16 mm)

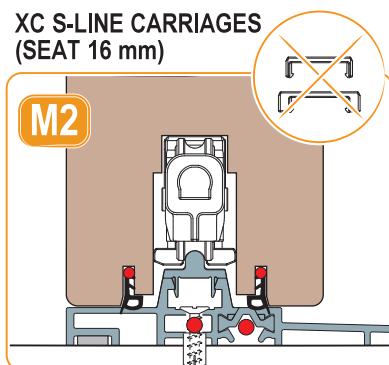

XC S-LINE CARRIAGES  
(SEAT 18 mm)

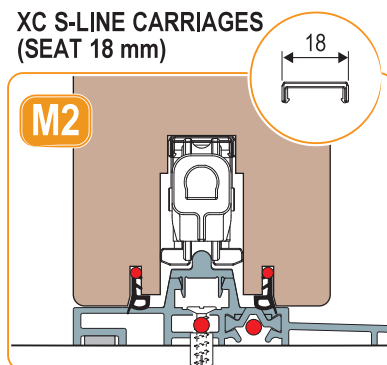

XC S-LINE CARRIAGES  
(SEAT 22 mm)

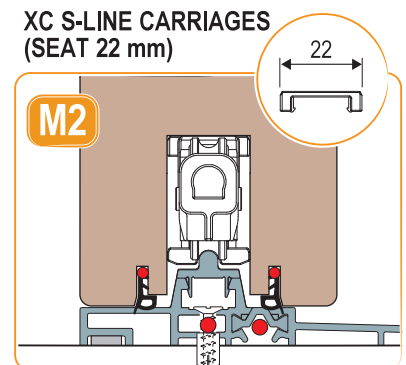

Wood millings: frame jamb horizontal section

|        |             |
|--------|-------------|
| SMT=56 | HET-STST-6  |
| SMT=45 | HET-STST-24 |

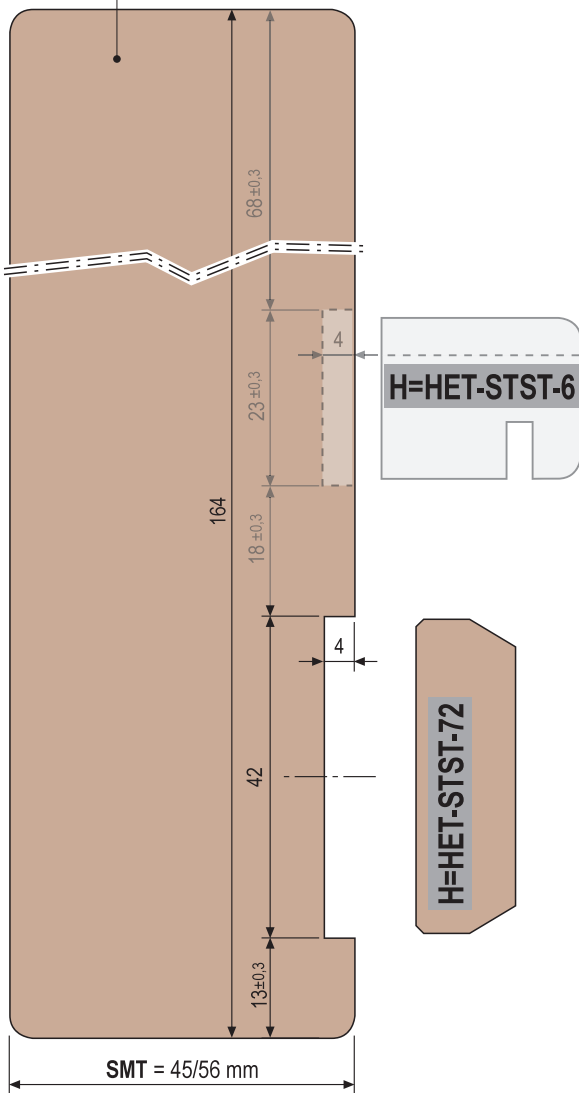

|        |             |
|--------|-------------|
| SMT=56 | HET-STST-6  |
| SMT=45 | HET-STST-24 |

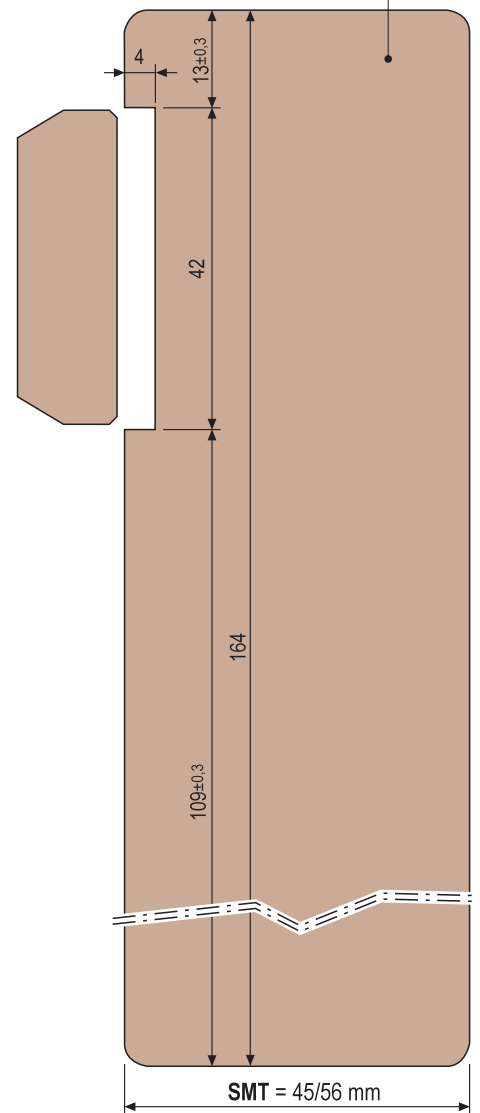

Wood millings: central point horizontal section

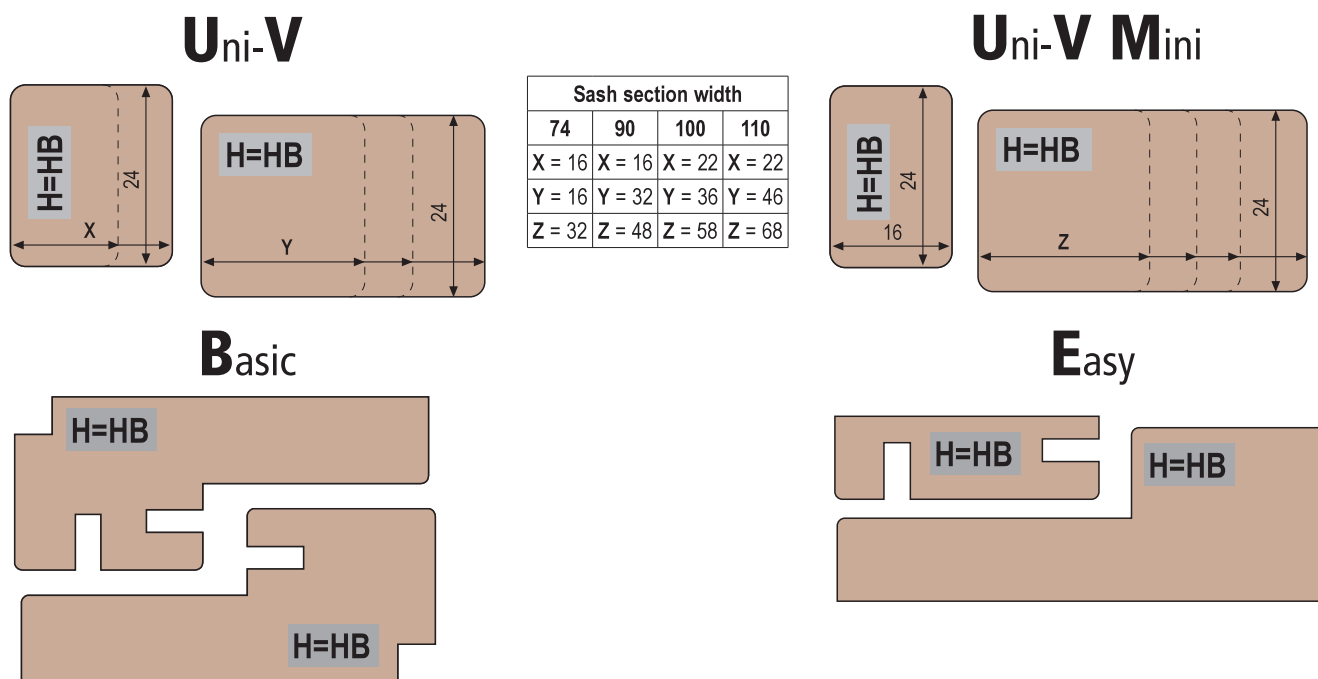

Wood millings: vertical section of upper frame transom

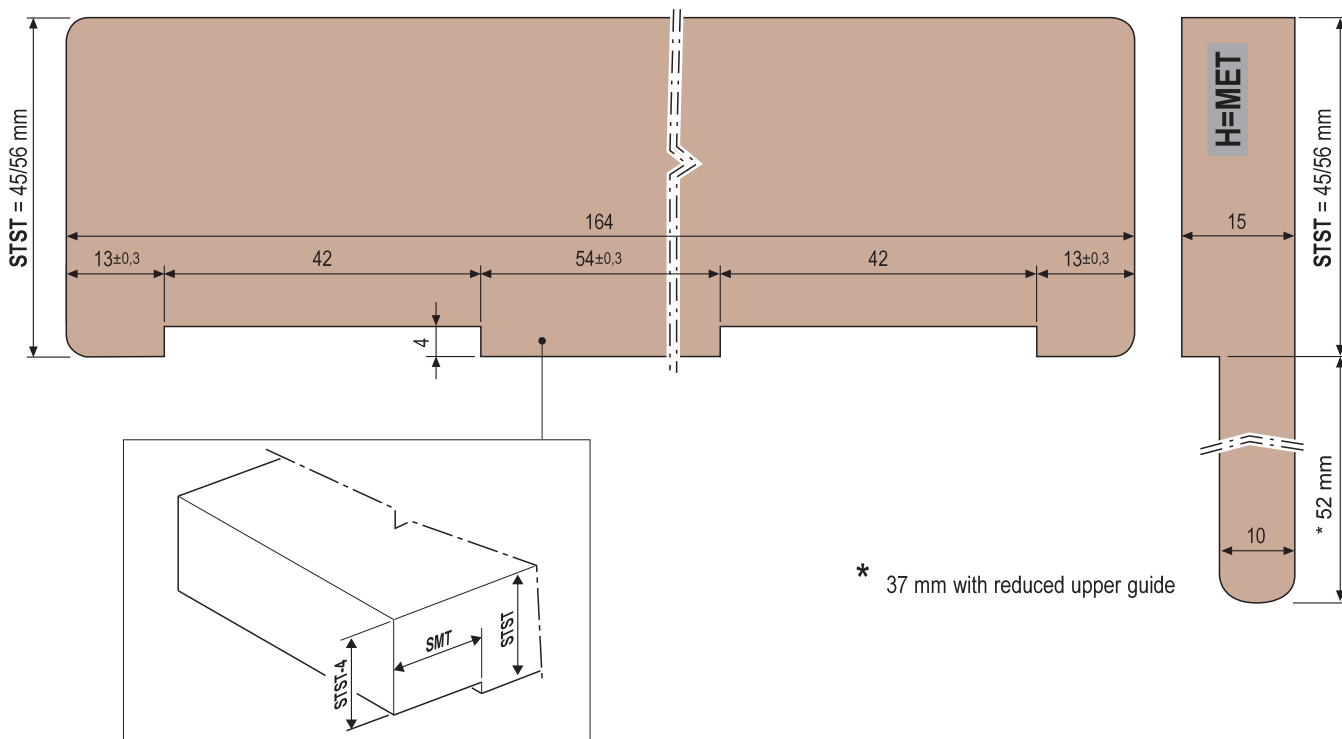

**Construction details, layouts B & F**

**TOP LOCKING PROFILE**



The top locking profile is not used. A top insulating pad positioned between the top guides is used.

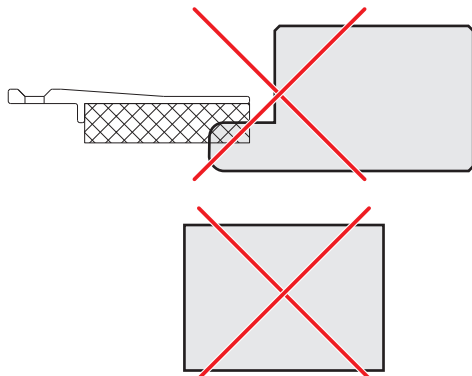

**REAR LOWER PAD CUT**



Cut the exceeding part of the lower pad according to the dimension of the XC S-LINE carriage seat.

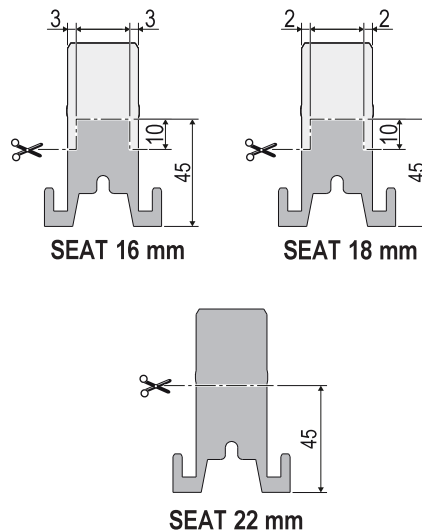

**BRUSH LISTELS FOR DECOMPRESSION CHAMBER**



The brush holder listel in the side point (layout B) is facultative.



**POSITION OF BOTTOM REAR SEALING PAD**



Position the bottom rear sealing pad between the cap and the anti-derail block.

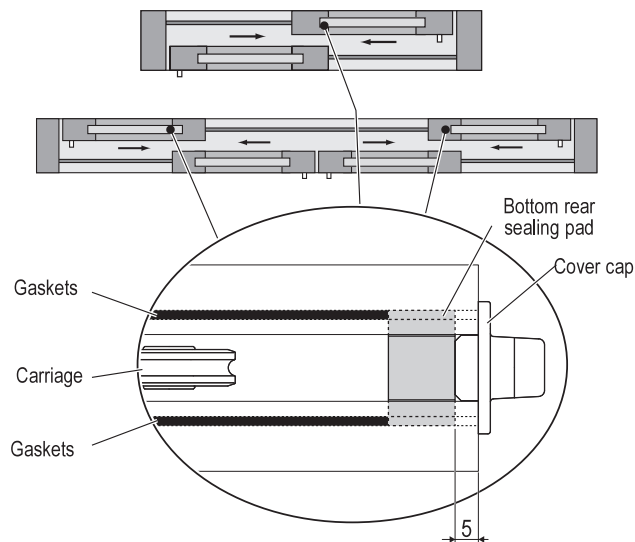

**USE OF BASIC FASTENING KIT AND COMPENSATOR CAPS**



Use the components as indicated in the table.

|                         | STST = 45    | STST = 56    |
|-------------------------|--------------|--------------|
| Versions distance 28 mm |              |              |
|                         | G01432.XX.YY | G01728.00.27 |

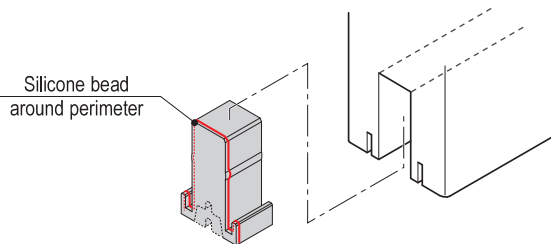

**Formulas of components cut**

|                           |                         | LAYOUT B                   | LAYOUT F                  |
|---------------------------|-------------------------|----------------------------|---------------------------|
|                           |                         |                            |                           |
|                           |                         |                            |                           |
|                           | <p><b>XC</b></p>        | HB-94                      | HB-94                     |
|                           | <p><b>XC S-Line</b></p> |                            |                           |
|                           | <p><b>XC</b></p>        |                            |                           |
|                           | <p><b>XC S-Line</b></p> |                            |                           |
|                           | <p><b>XC</b></p>        | <p>2 (pieces) 80 mm + </p> |                           |
| with additional carriages | <p><b>XC S-Line</b></p> | <p>2 (pieces) 80 mm + </p> |                           |
|                           |                         | MET                        | MET                       |
|                           |                         | MET-2xSMT-2                | MET-2xSMT-2               |
|                           |                         | MET-2xSMT-2                | MET-2xSMT-2               |
|                           |                         | 2 (pieces)<br>MET-2xSMT-2  | 2 (pieces)<br>MET-2xSMT-2 |

|  |             |
|--|-------------|
|  | HET-STST-72 |
|  | HB-75       |

|  |       |
|--|-------|
|  | HB-10 |
|  | HB-4  |
|  | HB-10 |

## LAYOUTS A & E, LAYOUTS B & F - ASSEMBLY OPERATIONS

### Positioning of central listels on sashes

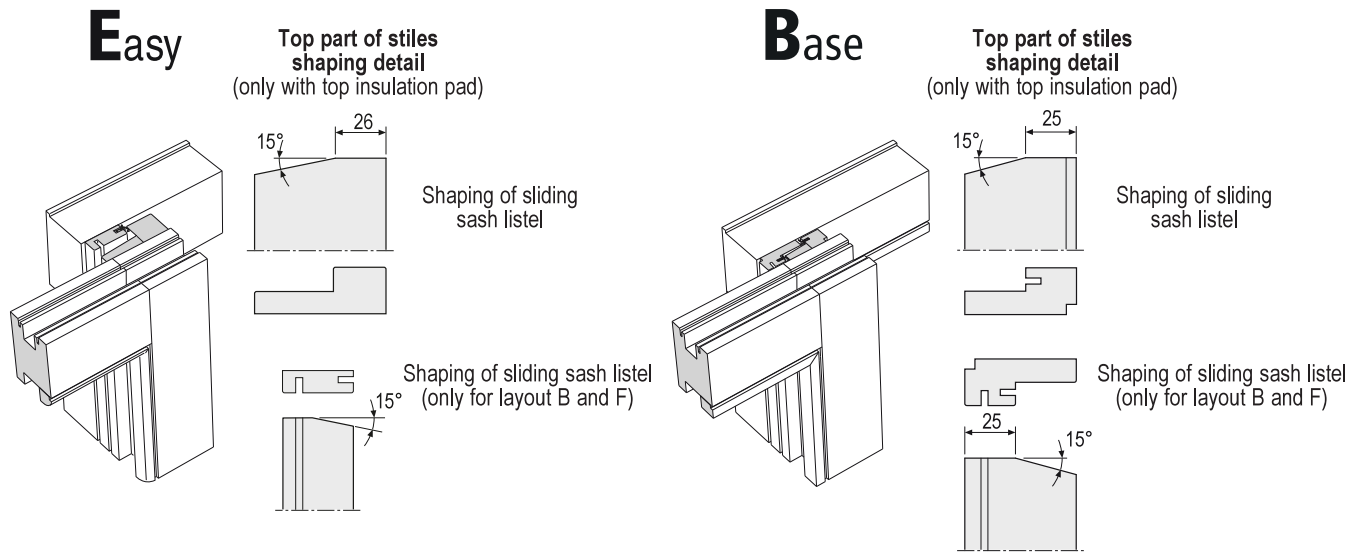

### Pad application on central jambs

Before installing the lower pads, make a silicone beadaround perimeter as indicated.

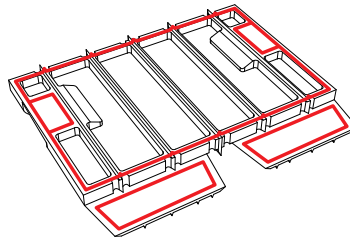



**Realisation of lock holes**

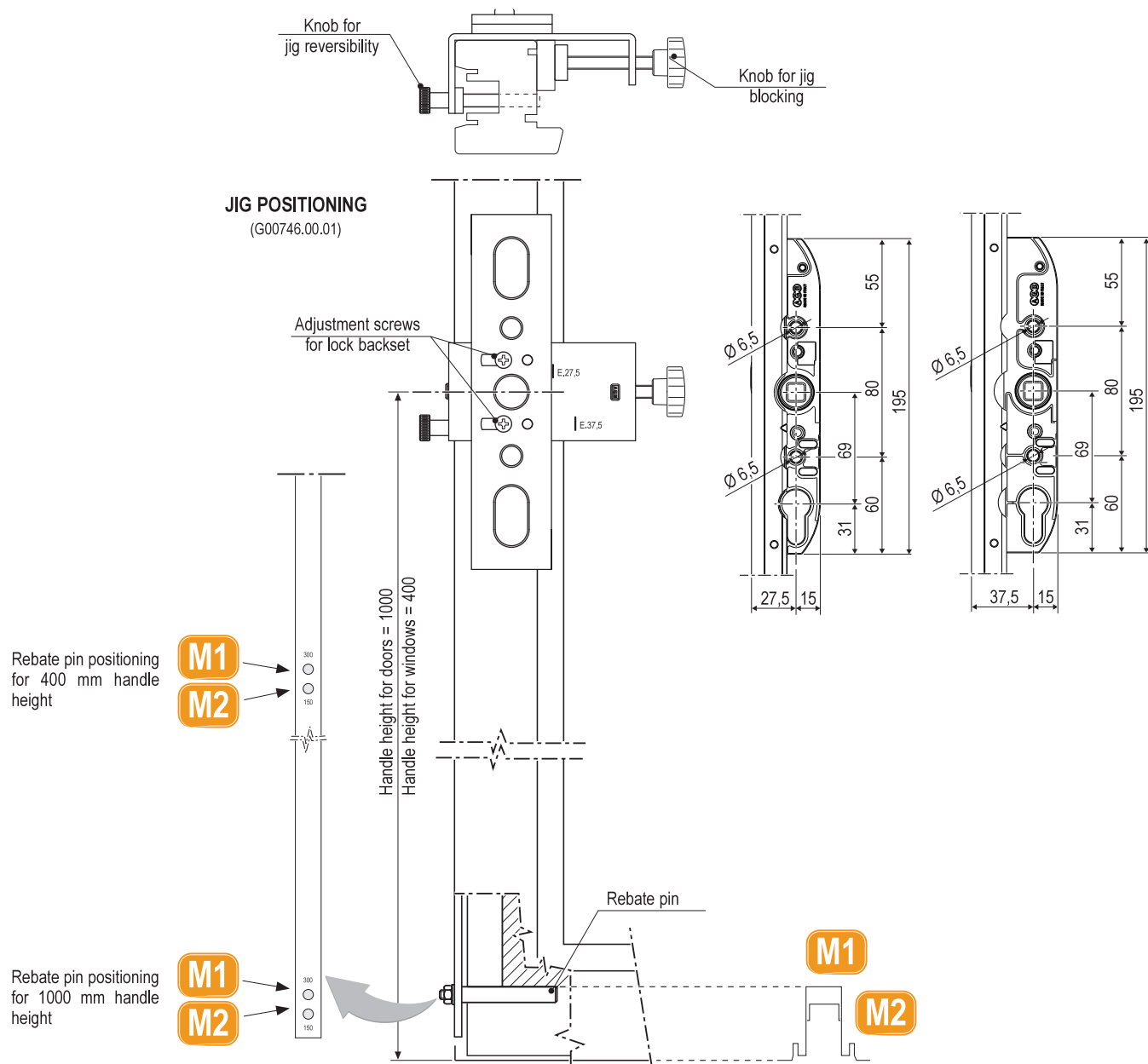

**M1**  
**M2**

**M1**  
**M2**

**M1**

**M2**

**DRILLING FOR HANDLE**

**DRILLING FOR EXTERNAL PULL HANDLE**

VIEW "A" - INT. SIDE

VIEW "B"

| Backset | X    |
|---------|------|
| 27      | 27,5 |
| 37      | 37,5 |

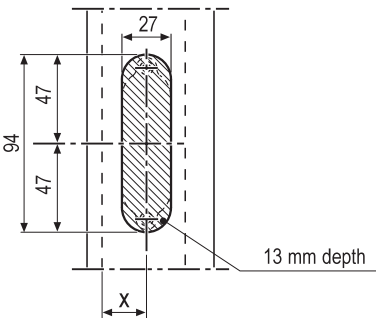
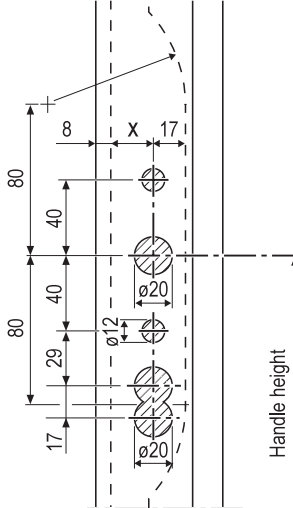
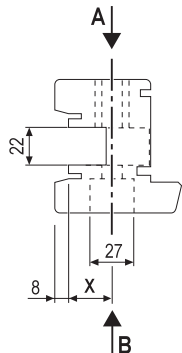

Accessories for single sash configuration with guide 22x22

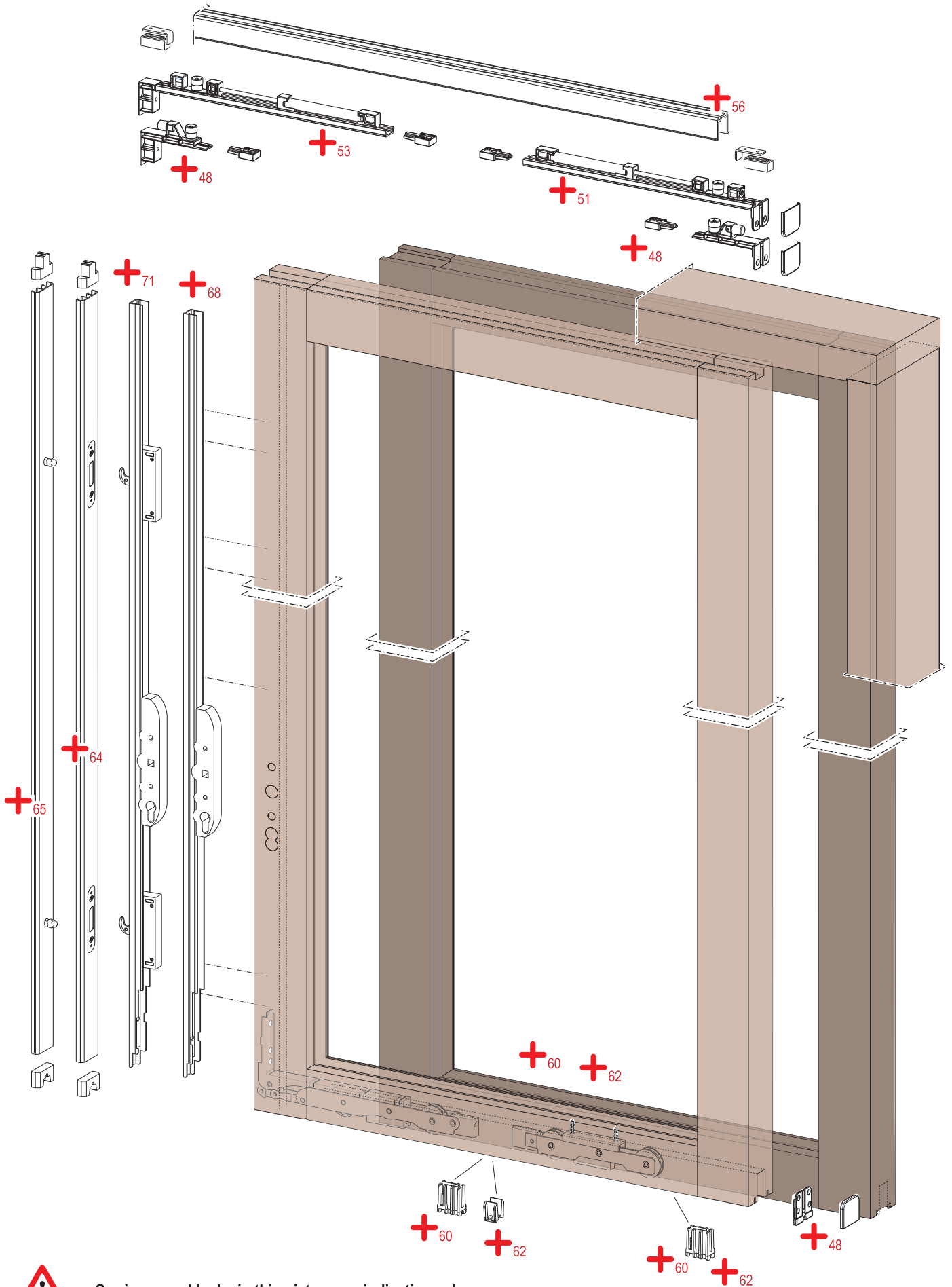

Carriages and locks in this picture are indicative only.

Accessories for single sash configuration with guide 22x13

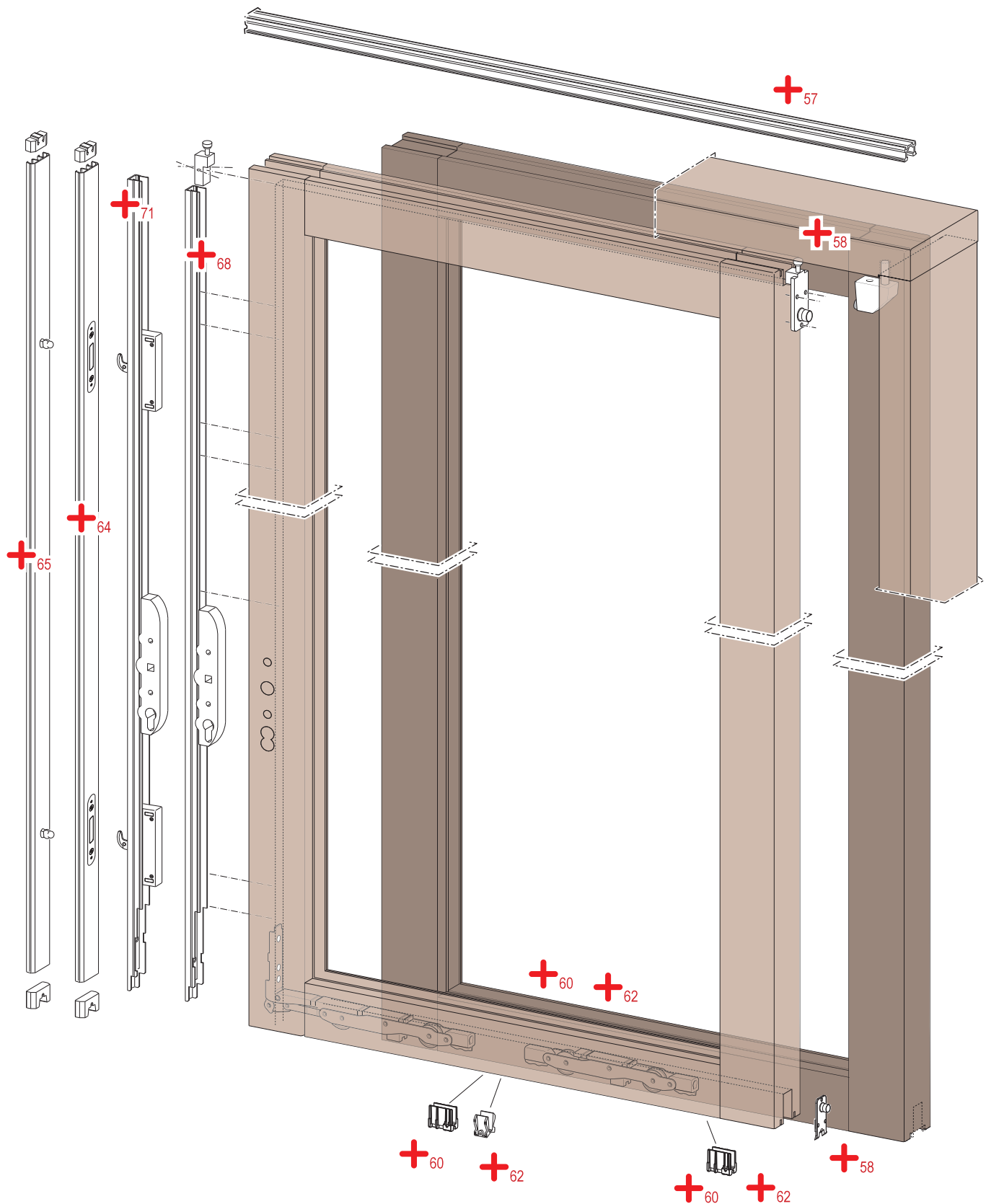

Carriages and locks in this picture are indicative only.

Accessories for coaxial sash configuration with guide 22x13

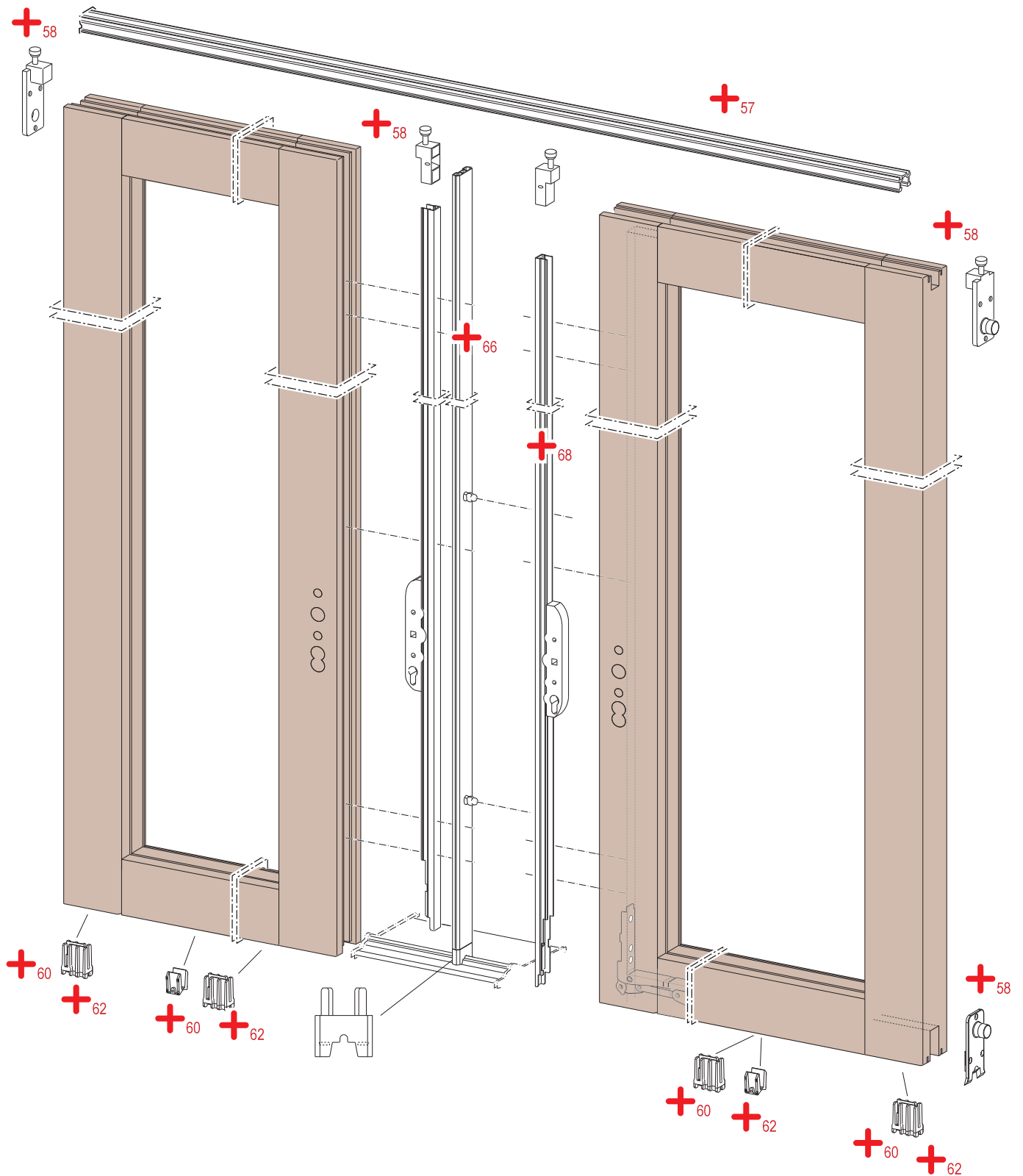

Carriages and locks in this picture are indicative only.

Accessories for coaxial sash configuration with guide 22x22

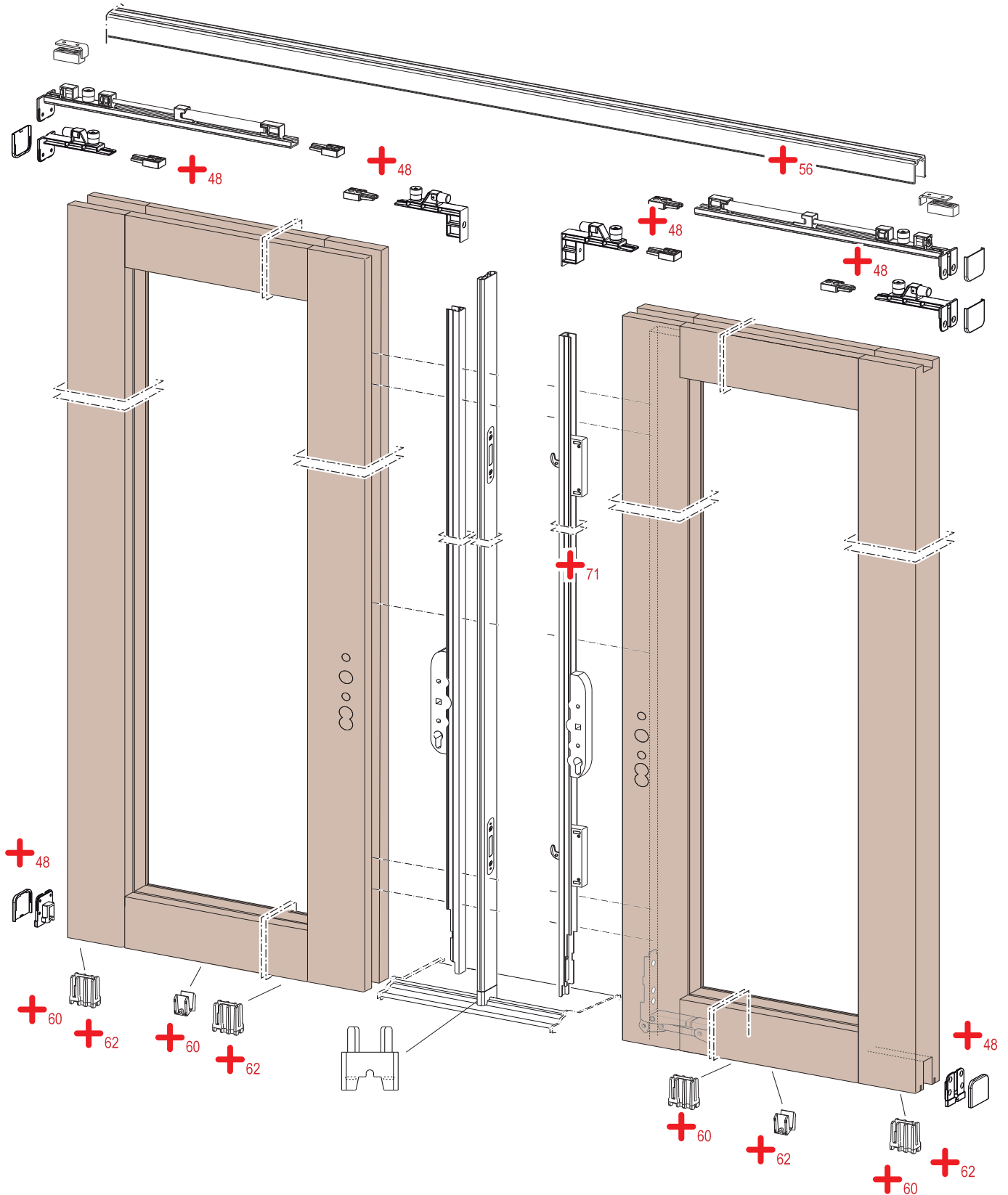

 Carriages and locks in this picture are indicative only.

Sash assembly

WITH REDUCED TOP GUIDE AND LOCKING PROFILE

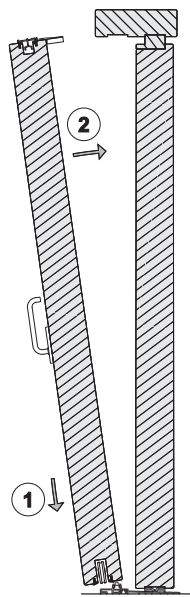

WITH TOP GUIDE AND INSULATING PAD

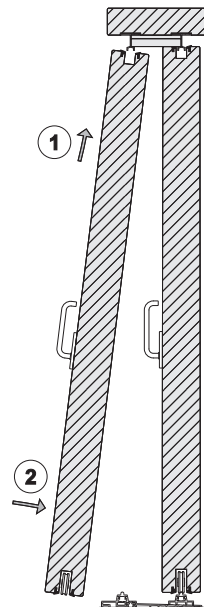

Locking pins assembly

**+**<sub>65</sub>

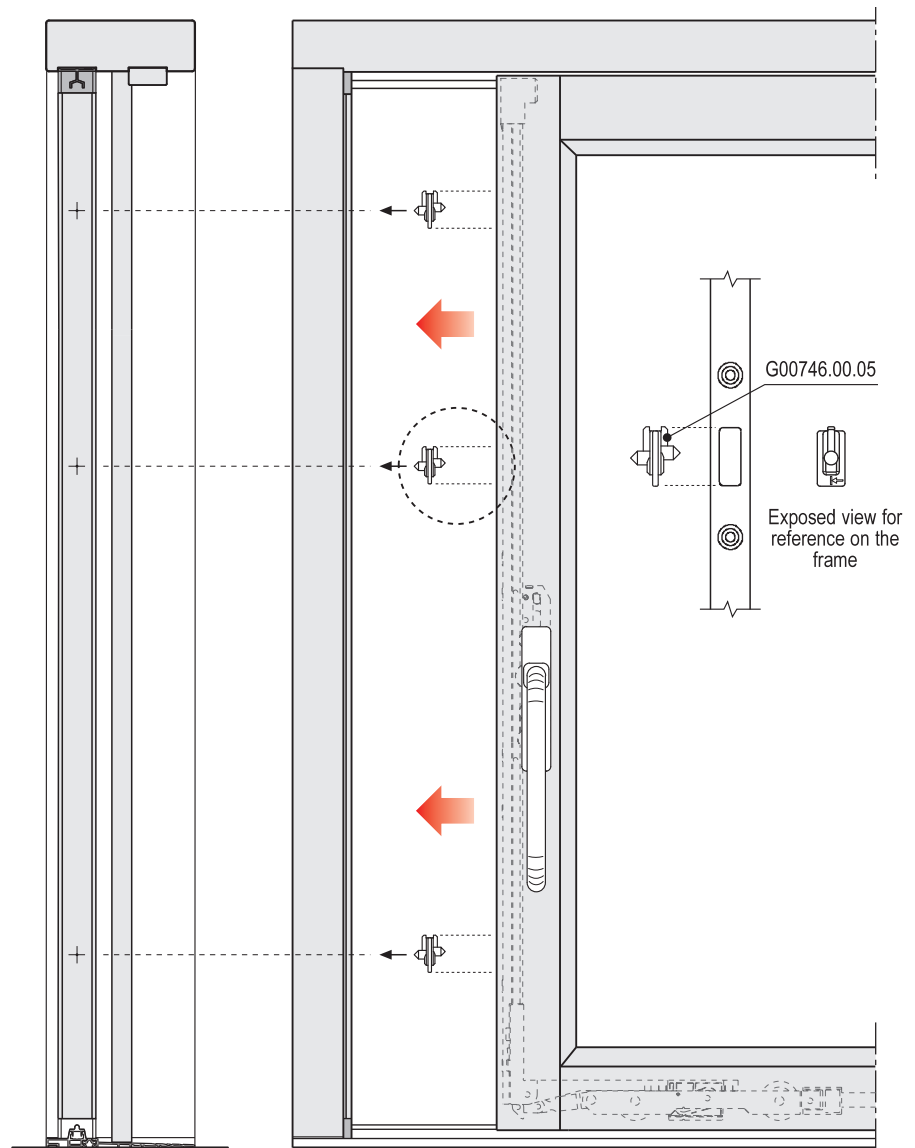
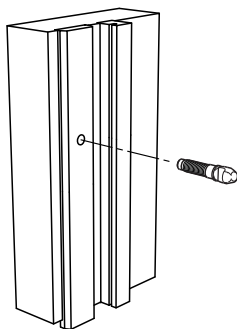
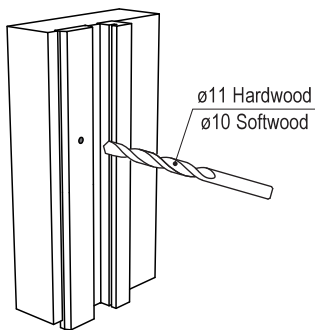

### Frame corner joint (alternative solution)



Solution valid only for systems with frame of a thickness of 56 mm; frame jamb-crossbeam assembly using G00728.00.23 kit ensures simple, safe mounting of the entire system, also ensuring optimal mechanical resistance and damp-proofing.

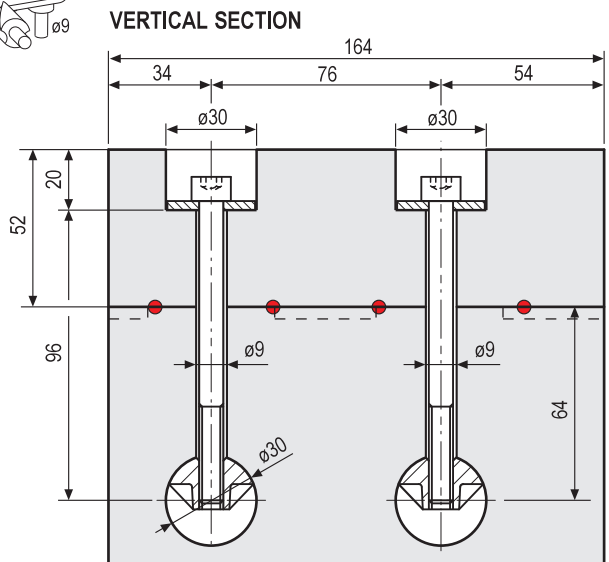
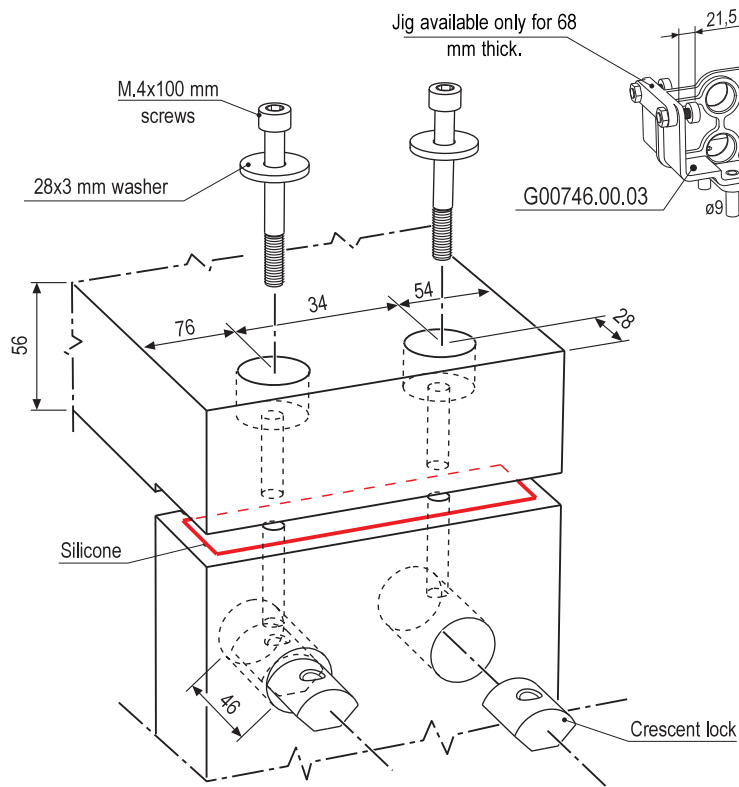

### Joint between frame and threshold (with 56 mm thickness frame)

ASSEMBLY OF LOWER CAPS

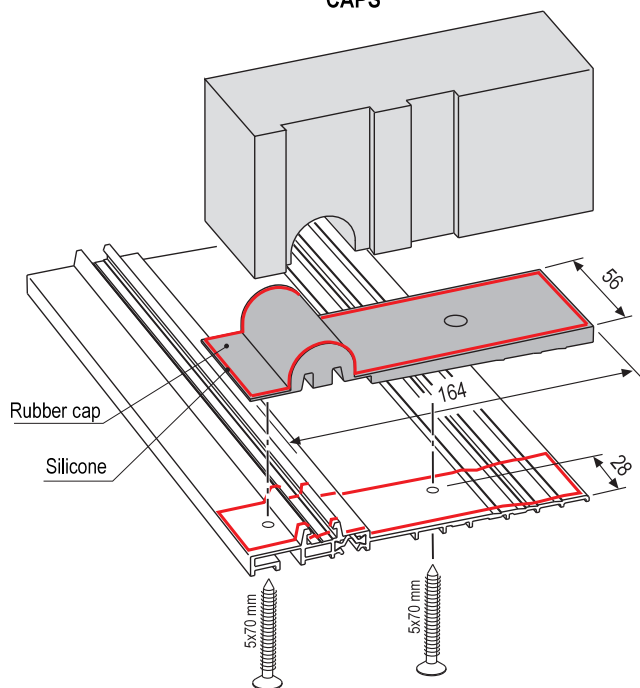

VERTICAL SECTION

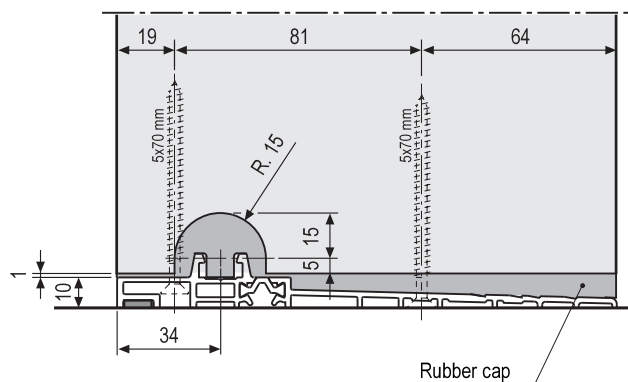

- For sliding sashes from lh to rh, use the kit G01412.SX.YY
- For sliding sashes from rh to lh, use the kit G01412.DX.YY
- For layouts D & E, order the kit G01412.00.YY

YY = 93 Black  
86 Grey RAL 7035

Joint between frame and threshold (with 45 mm frame thickness)

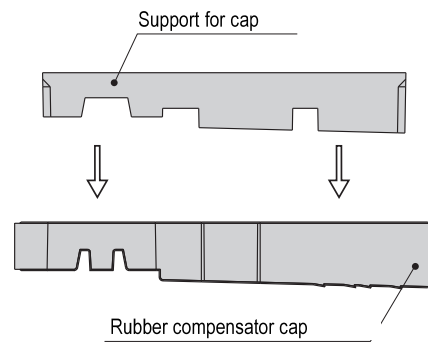
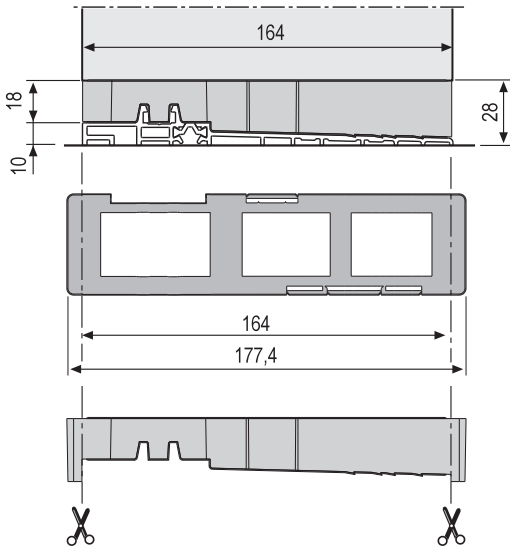
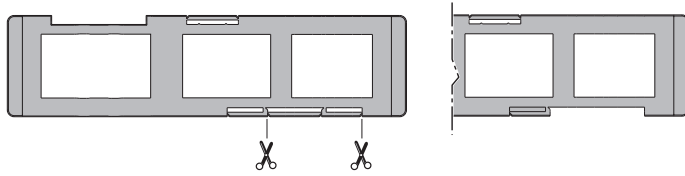

**LOWER CAPS ASSEMBLY**

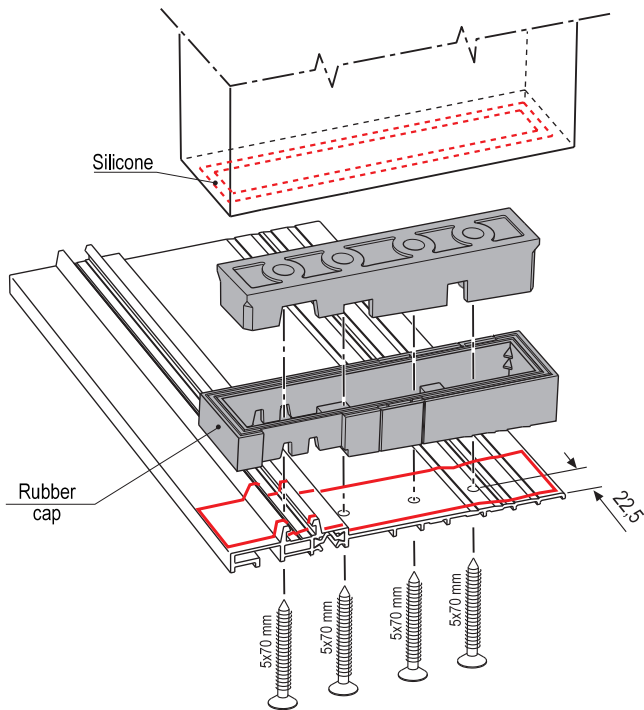

**VERTICAL SECTION**

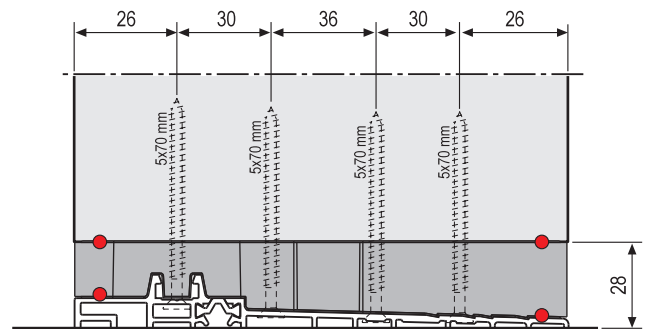



### Use of gas spring kit

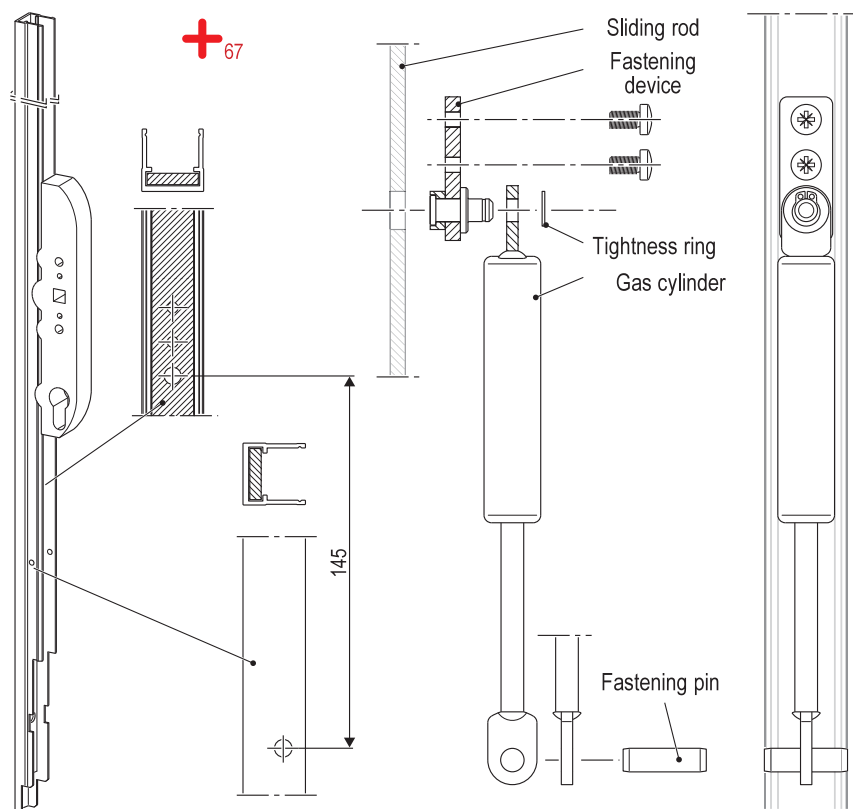

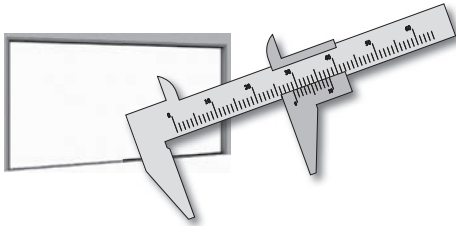
**STEPS FOR CONTROL OF PRODUCTION PROCESS (FPC)****Frame components measurement and solutions for air-water tightness**

- 1 - Find the length and width of upper transom and vertical jambs.
- 2 - Check the length and depth of millings to host the aluminium upper guide and wooden listels are compliant to what indicated in this technical manual.
- 3 - Check the width and length of listels.
- 4 - Check that the length of threshold, the sliding profile and the glass holder profile corresponds to the indications of this technical manual.

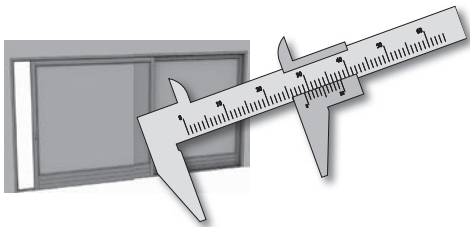
**Sashes components measurement and solutions for air-water tightness**

- 1 - According to the frame measurements, please calculate the sashes measurements according to the indications reported in the technical manual (LxH) and check that sash dimensions are compliant to the ones calculated before.
- 2 - Check the sashes orthogonality (square) measuring the diagonals, it is very important they are equal for the correct functioning and closing.
- 3 - Check the sash adapter is exactly the one indicated in this manual.
- 4 - Check the millings width for the carriages housing and check that they are in the middle of the sash thickness.
- 5 - Check the depth and width of millings to host the gaskets checking the status, they can't have dirt or glue/paint.
- 6 - Check the depth and position the lock milling.
- 7 - Check the coplanarity of jamb/lower transom joints, eventually level with stucco in order to keep the tightness strong.
- 8 - The double glazing glass has to be siliconed flush to the rebate, perimetrically from outside, on wooden frames and aluminium glass holder profile.
- 9 - Silicone even on internal glass holder or use specific gaskets.
- 10 - Make a silicone bead around perimeter inside the external lower gasket groove before inserting it.

## **TECHNICAL ATTACHMENTS**

# Caps kit for embedded upper guide 22x22

| Article                                      | Ref. | Description   | Material                         | Use   | Fastening                     |
|--|------|---|----------------------------------|---|-------------------------------|
| Rear lower cap                               | ❶    | It covers the carriages milling of the lower transom.         | Plastic material                 | It covers the sash lower milling.                                   | 3,5x20 mm screws.             |
| Cover (2x)                                   | ❷    | Cover for the lower cap and the rear bumper glider.           | Plastic material                 | It covers the lower cap and the fastening of the upper rear glider. | Snap-in                       |
| Shaped cap for upper guide                   | ❸    | Cap to be inserted between the locking profile and the guide. | Rubber                           | To be jointed.  | To be inserted with silicone. |
| Shaped cap for lower rail                    | ❹    | To guarantee the system tightness.                            | Rubber                           | Apply under the profile with silicone on the back.                  |                               |
| Device for frame guide                       | ❺    | Rebate for the glider pad or for the damper.                  | Zamak                            | To be placed and fastened into the upper guide.                     | 4x45 mm screws.               |
| Glider fastening hold-device and damper (2x) | ❻    | Mechanical block of the glider.                               | Zamak                            | Fasten using front and rear caps as a jig.                          | 4x30 mm screws.               |
| Front cap with reference glider              | ❼    | Sliding glider and closing brake.                             | Plastic material / zamak / steel | To fasten the sash in opening.                                      | 4x30 mm screws.               |
| Damper kit with closing brake                | ❽    | Sliding glider and opening brake.                             | Plastic material / zamak / steel | To fasten the sash in opening.                                      | 4x30 mm screws.               |
| Fixed sash adapter (x4)                      | ❾    | Filling adapter for fixed sash.                               | Plastic material                 | Compensator adapter between sash and frame.                         | To be inserted.               |

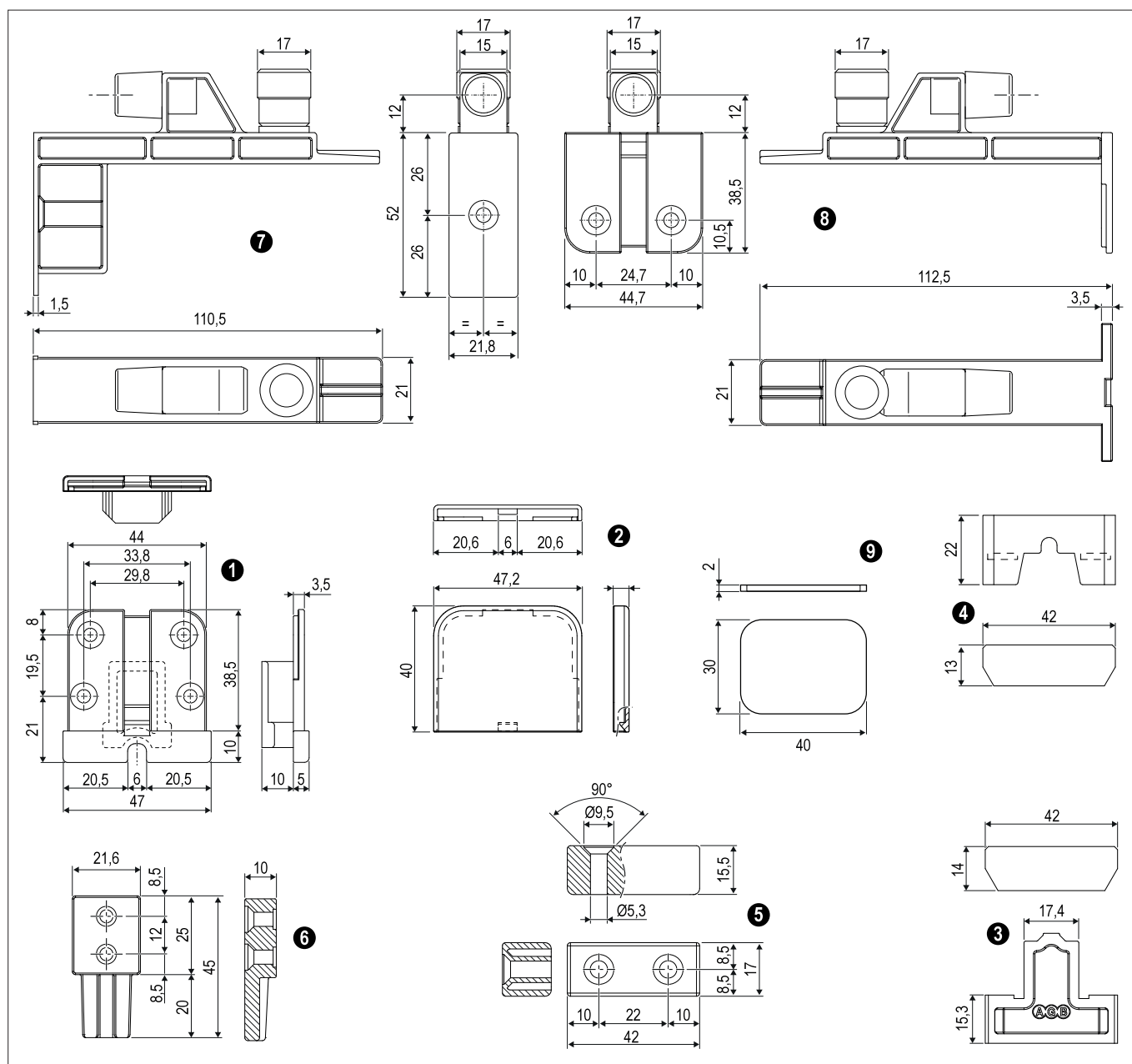

# Caps kit for embedded upper guide 22x22

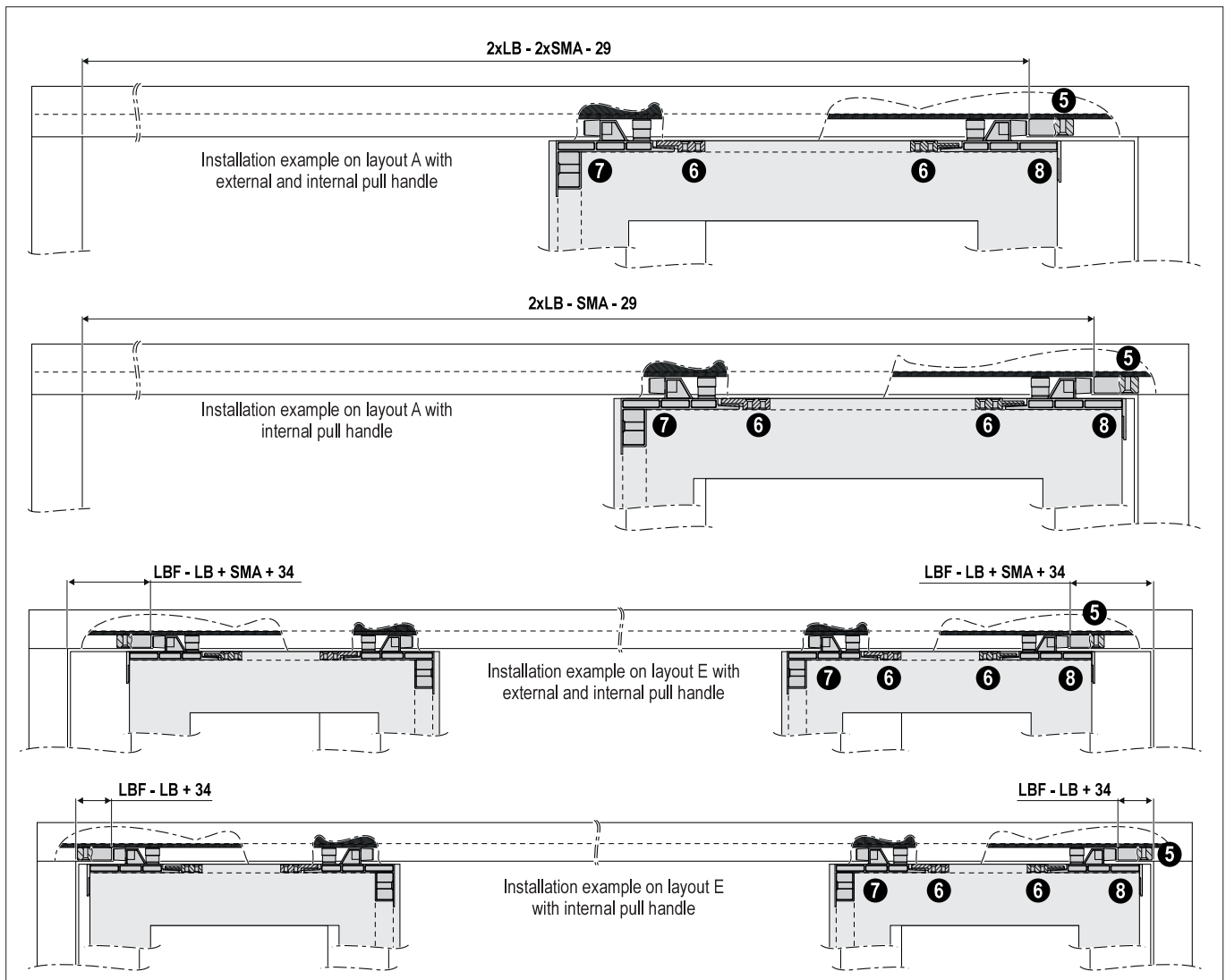
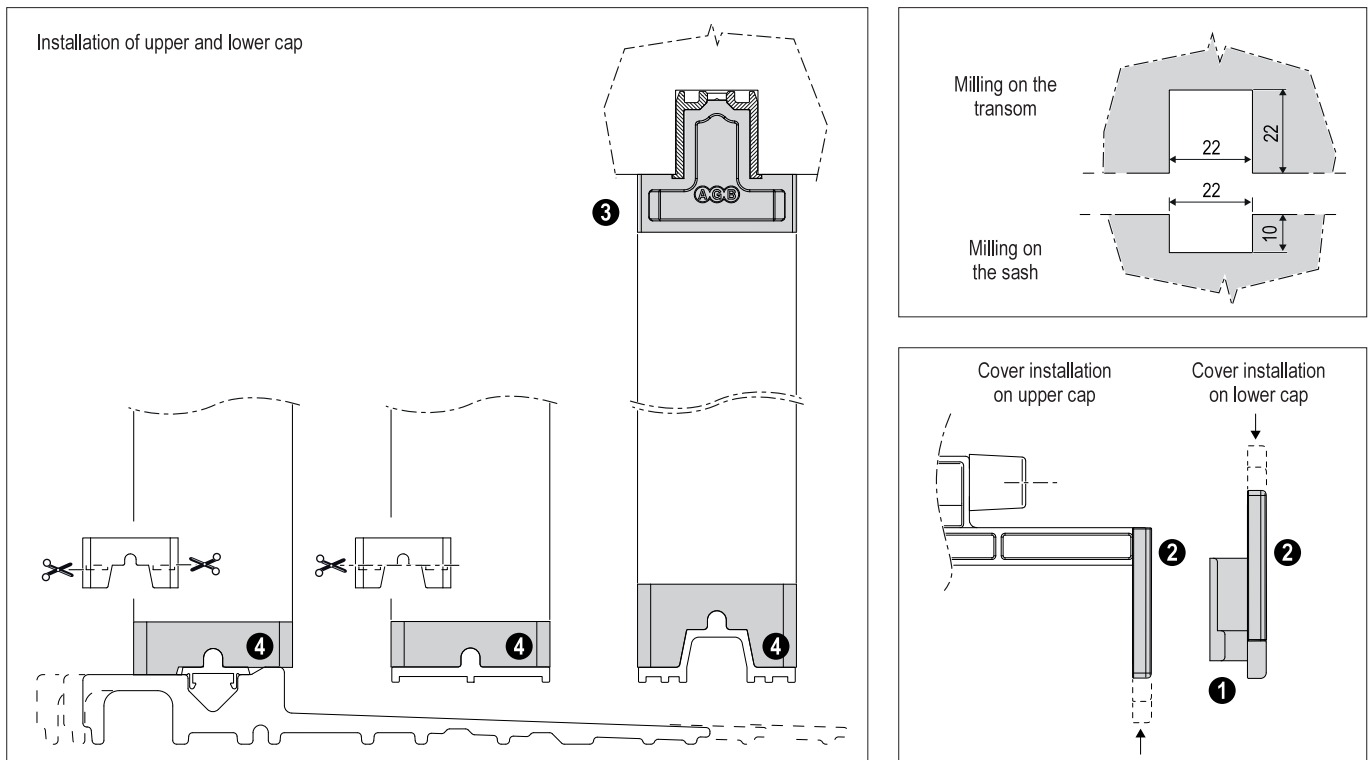

## Caps kit for embedded upper guide 22x22

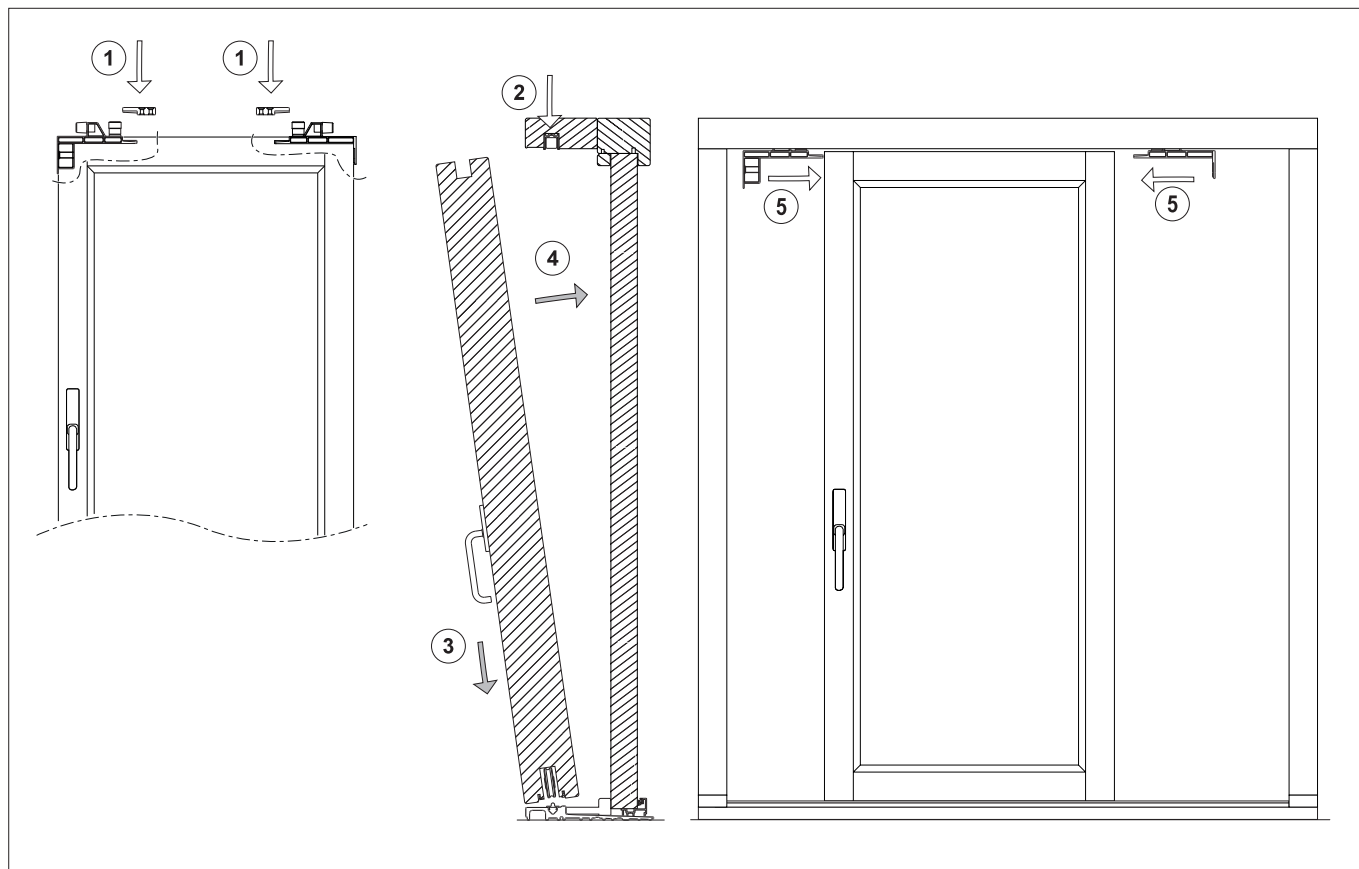

- ① Using the glider/s as a jig, fasten the hold device/s into the sliding sash, not installed yet; then, remove the caps;
- ② Place the device/s in the right position indicated in this technical documentation;
- ③ Place the sash on the rail with the carriages in opening position;
- ④ Place the sash in vertical position;
- ⑤ Fasten the gliders on the sliding sash.

| Article                                 | Grey RAL 7035 | Black        |
|---|---------------|--------------|
| Caps kit for embedded upper guide 22x22 | G00232.00.86  | G00232.00.93 |

## Damper kit with opening brake

| Article                         | Ref. | Description   | Material                         | Use   | Fastening       |
|---------------------------------|------|---|----------------------------------|---|-----------------|
| Rear cap with glider as a guide | ❶    | Sliding glider and opening brake.                   | Plastic material / zamak / steel | To fasten the sash in opening.                                    | 4x30 mm screws. |
| Magnetic contrast               | ❷    | It allows the damper activation in closing/opening. | Steel                            | To be applied under the contrast as a guide if you use the brake. | 4x30 mm screws. |

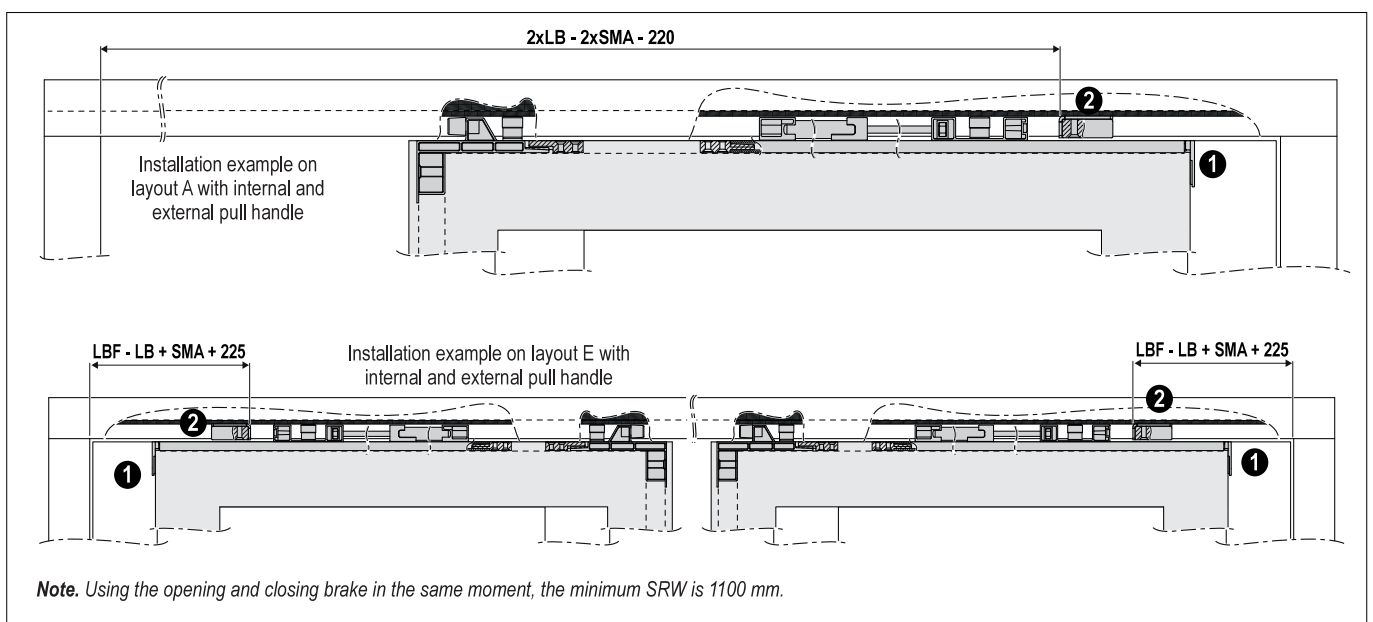
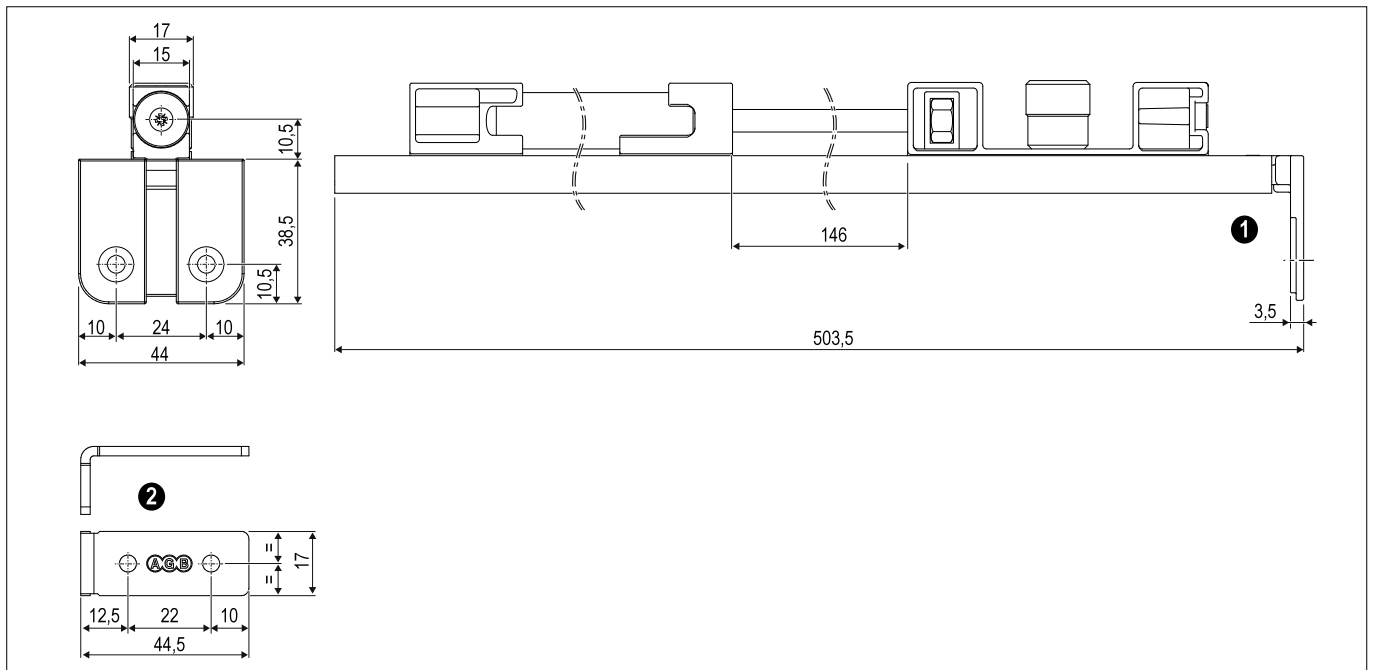

## Damper kit with opening brake

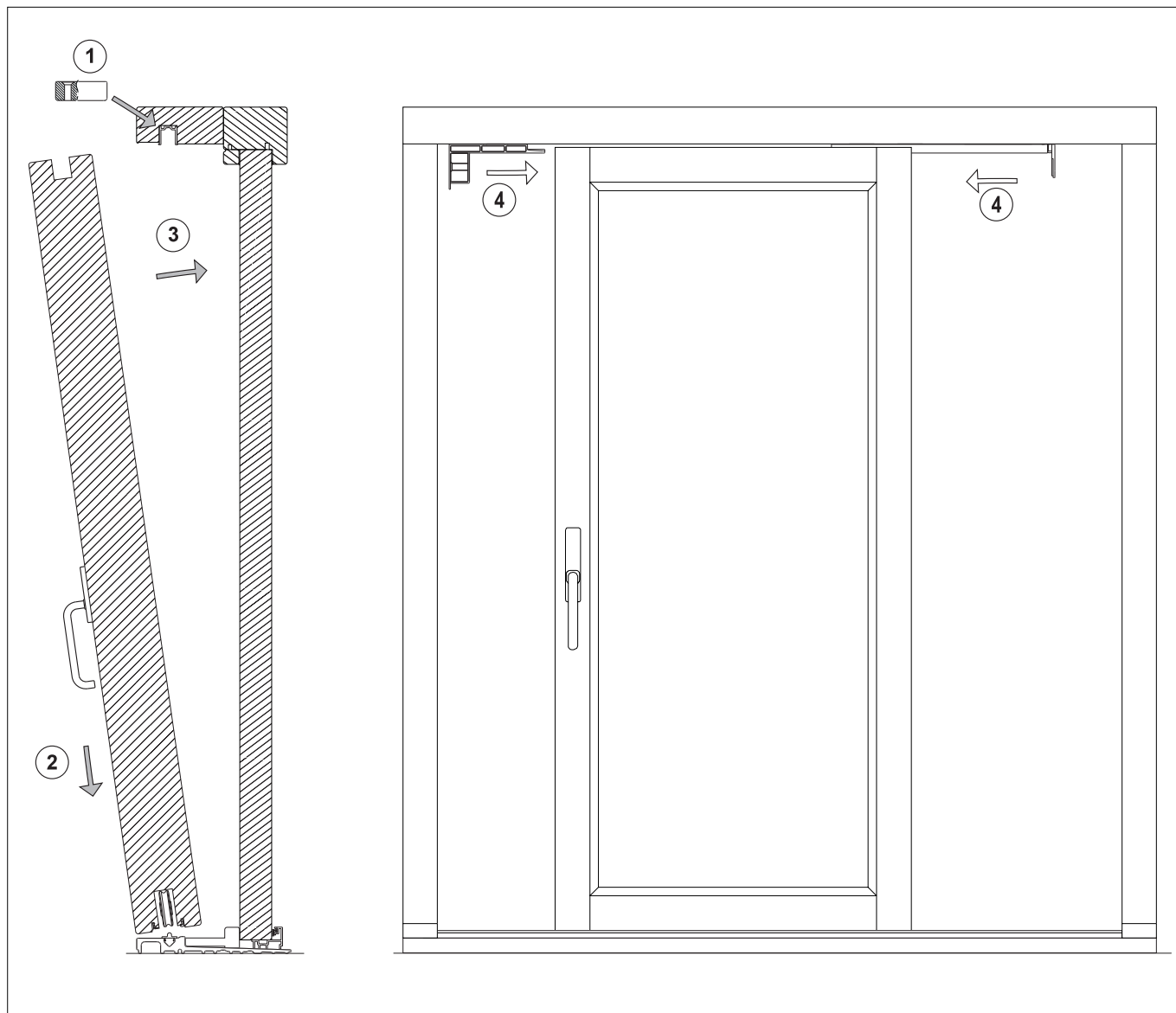

- ① Place the device/s in the right position indicated in this technical documentation;
- ② Place the sash on the rail with the carriages in opening position;
- ③ Place the sash in vertical position;
- ④ Fasten the gliders on the sliding sash.

| Article                     | Grey RAL 7035 | Black        |
|-----------------------------|---------------|--------------|
| Loading capacity 80-200 kg  | G00232.13.86  | G00232.13.93 |
| Loading capacity 200-440 kg | G00232.14.86  | G00232.14.93 |



## Damper kit with closing brake

| Article                | Ref. | Description                                  | Material                         | Use   | Fastening       |
|------------------------|------|--|----------------------------------|---|-----------------|
| Front cap with damper  | ❶    | Sliding glider and closing brake.            | Plastic material / zamak / steel | To stop the sash in opening.                                      | 4x30 mm screws. |
| Magnetic contrast      | ❷    | It allows the damper activation in opening.  | Steel                            | To be applied under the contrast as a guide if you use the brake. | 4x45 mm screws. |
| Device for frame guide | ❸    | Rebate for the glider pad or for the damper. | Zamak                            | -   | 4x45 mm screws. |

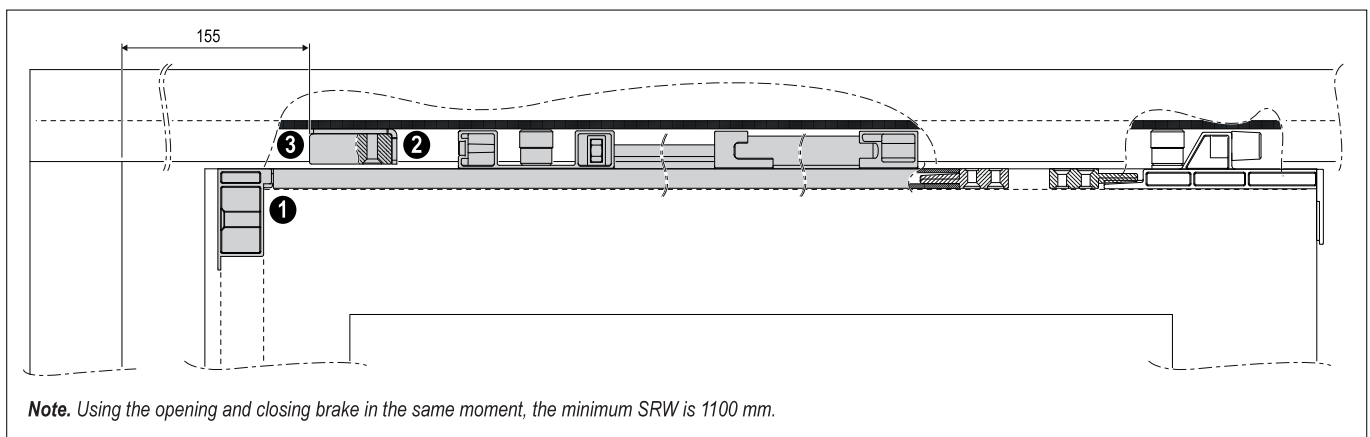
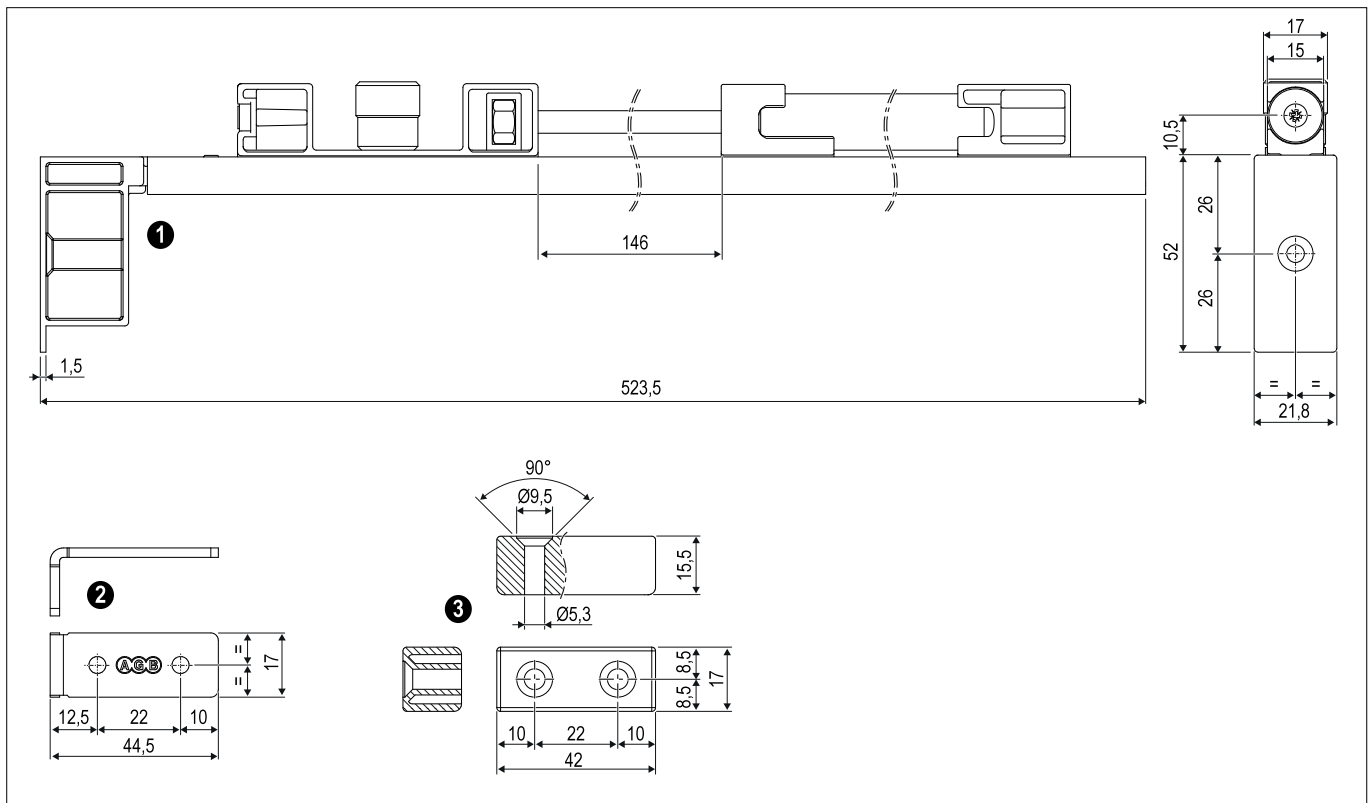

**Note.** Using the opening and closing brake in the same moment, the minimum SRW is 1100 mm.

## Damper kit with closing brake

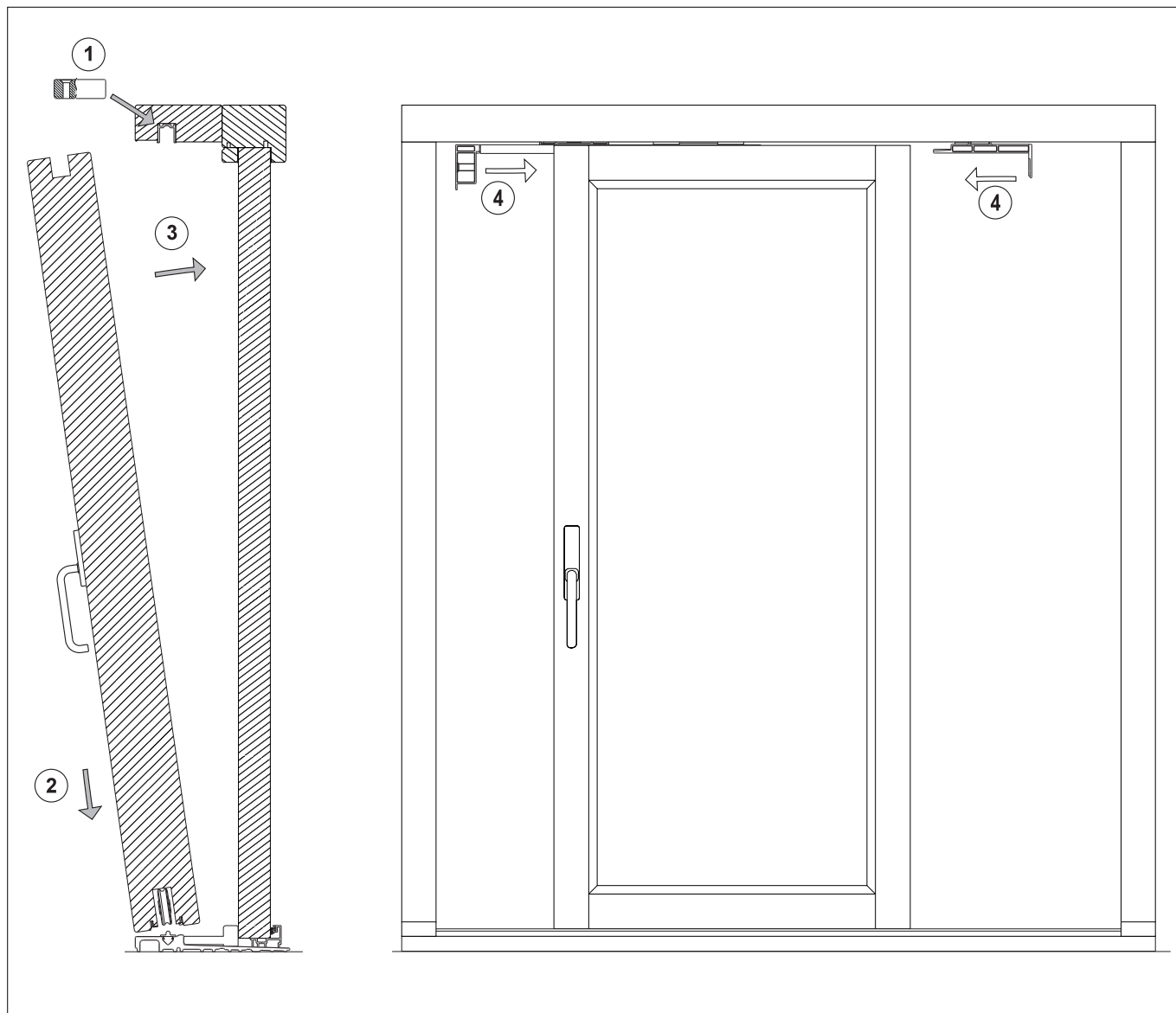

- ① Place the device/s in the right position indicated in this technical documentation;
- ② Place the sash on the rail with the carriages in opening position;
- ③ Place the sash in vertical position;
- ④ Fasten the gliders on the sliding sash.

| Article                     | Grey RAL 7035 | Black        |
|-----------------------------|---------------|--------------|
| Loading capacity 80-200 kg  | G00232.11.86  | G00232.11.93 |
| Loading capacity 200-440 kg | G00232.12.86  | G00232.12.93 |

## Guida superiore ridotta

| Articolo                | Descrizione  | Materiale | Fissaggio   |
|-------------------------|--|-----------|-------------|
| Guida superiore ridotta | Profilo guida in alluminio anodizzato, con fori vite ogni 30 cm. | Alluminio | Viti 3,5X30 |

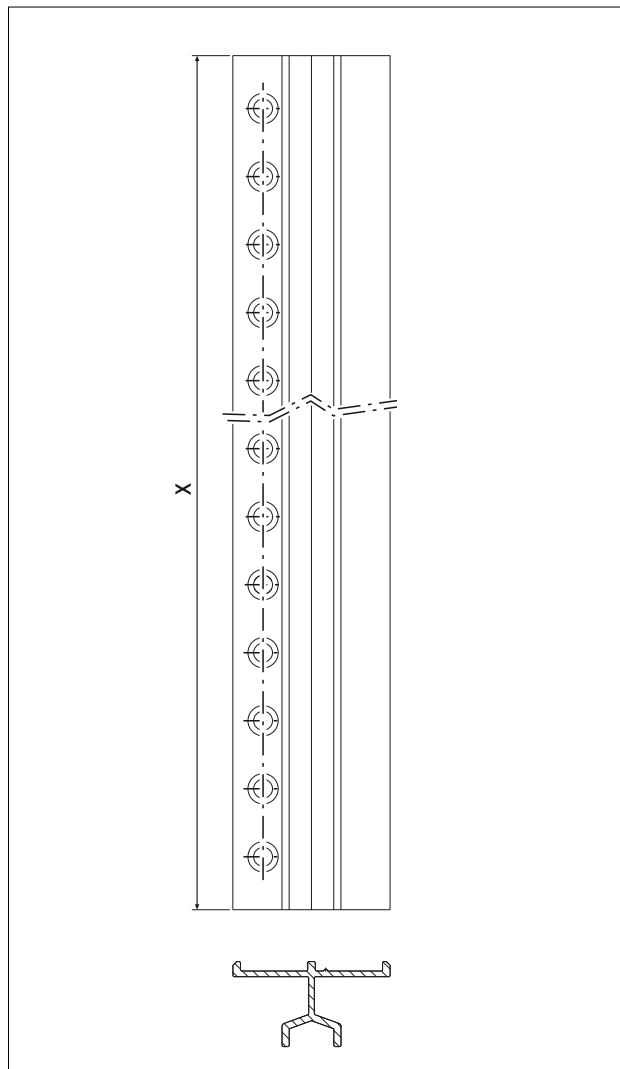

| Rif. | Articolo                | Codice art. Argento | Codice art. Alluminio Nero | X    |
|------|-------------------------|---------------------|----------------------------|------|
| 1    | Guida superiore ridotta | G01734.01.01        | G01734.01.02               | 3000 |
|      |                         | G01734.02.01        | G01734.02.02               | 4000 |
|      |                         | G01734.03.01        | G01734.03.02               | 5000 |
|      |                         | G01734.04.01        | G01734.04.02               | 6000 |
|      |                         | G01734.05.01        | G01734.05.02               | 7000 |

## Embedded upper guide 22x22

| Article              | Ref.     | Description  | Material  | Use   | Fastening       |
|----------------------|----------|--|-----------|---|-----------------|
| Embedded upper guide | <b>1</b> | Guide for sliding gliders of the sliding sash, compatible with AGB systems of closing/opening brake. | Aluminium | Insert in the dedicated milling of the frame upper transom. | 4x25 mm screws. |

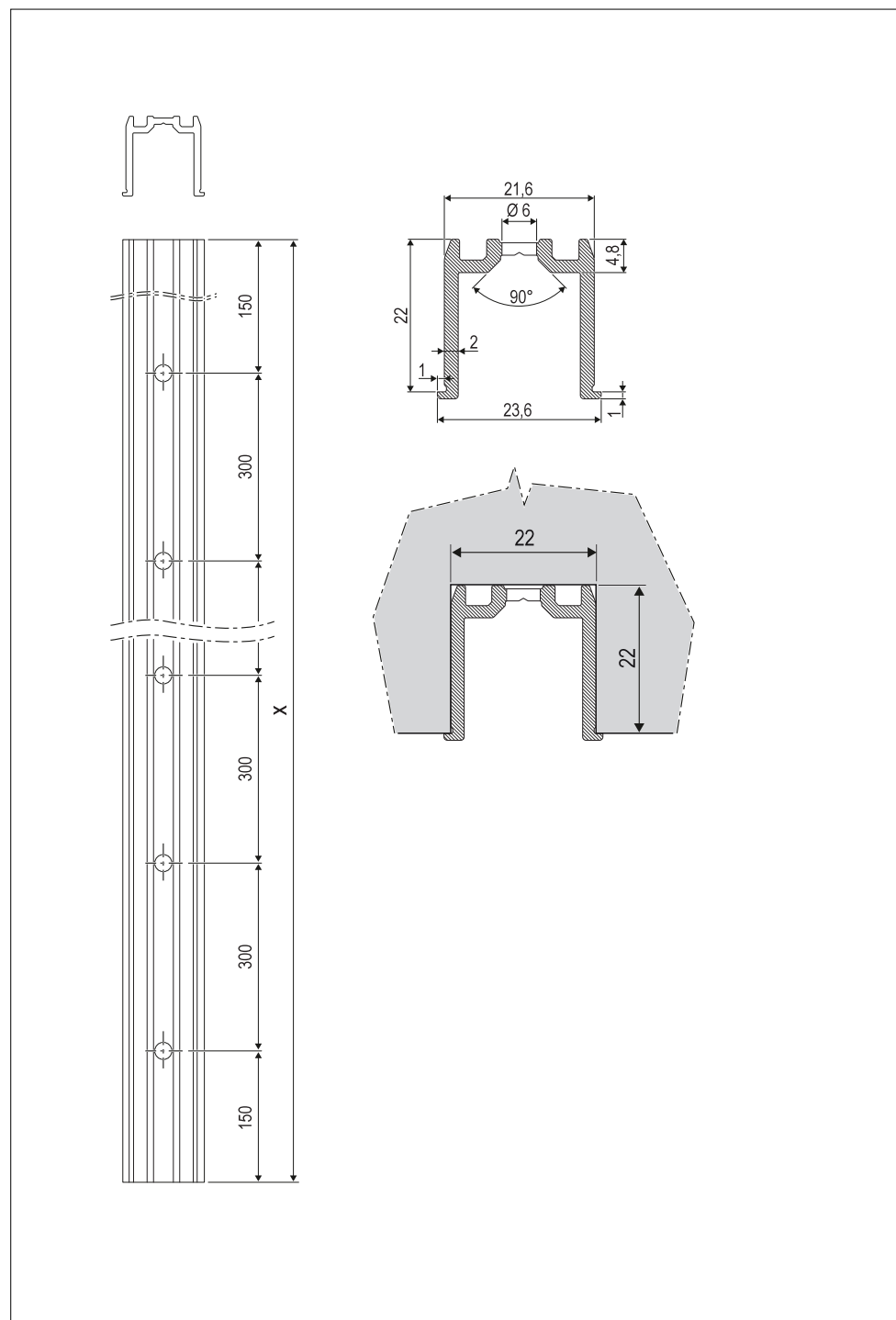

| Ref.     | Article              | Article code, in Silver | Article code, in Electrocolour | X    |
|----------|----------------------|-------------------------|--------------------------------|------|
| <b>1</b> | Embedded upper guide | G01002.01.01            | G01002.01.02                   | 3000 |
|          |                      | G01002.02.01            | G01002.02.02                   | 4000 |
|          |                      | G01002.03.01            | G01002.03.02                   | 5000 |
|          |                      | G01002.04.01            | G01002.04.02                   | 6000 |
|          |                      | G01002.05.01            | G01002.05.02                   | 7000 |

## Embedded upper guide 22x13

| Article                    | Ref. | Description                                   | Material  | Use   | Fastening       |
|----------------------------|------|---|-----------|---|-----------------|
| Embedded upper guide 22x13 | ❶    | Guide for sliding gliders of the movable rod. | Aluminium | Insert in the dedicated milling of the frame upper transom. | 4x25 mm screws. |

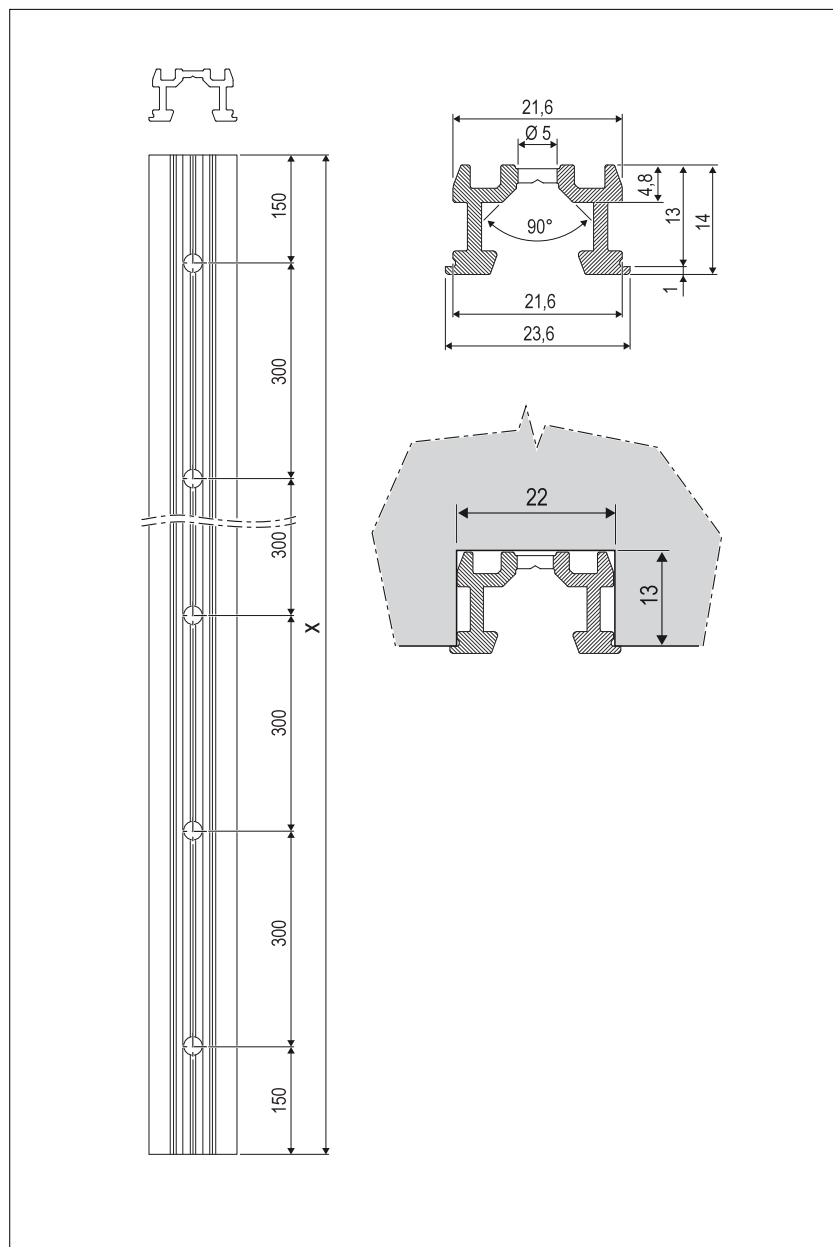

| Ref. | Article                    | Article code, in Silver | Article code, in Electrocolour | X    |
|------|----------------------------|-------------------------|--------------------------------|------|
| ❶    | Embedded upper guide 22x13 | G01000.01.01            | G01000.01.02                   | 3000 |
|      |                            | G01000.02.01            | G01000.02.02                   | 4000 |
|      |                            | G01000.03.01            | G01000.03.02                   | 5000 |
|      |                            | G01000.04.01            | G01000.04.02                   | 6000 |
|      |                            | G01000.14.01            | G01000.14.02                   | 7000 |

# Caps kit for embedded upper guide 22x13 - low rail

| Article                              | Ref.     | Description  | Material         | Use  | Fastening                     |
|--------------------------------------|----------|--|------------------|--|-------------------------------|
| Shaped cap for C track 22x13         | <b>1</b> | Cap to be inserted between the locking profile and the guide.  | Rubber           | To be jointed.                                     | To be inserted with silicone. |
| Shaped cap for lower rail            | <b>2</b> | To guarantee the system tightness.   | Rubber           | Apply under the profile with silicone on the back. |                               |
| Rear lower covering cap              | <b>3</b> | Cap to close the hardware groove on the lower transom, in the sash extremity.  | Plastic material | -  | 4x30 mm screws.               |
| Cap and glider for front upper guide | <b>4</b> | Glider for the sash sliding on the concealed guide; the plastic glider is used as covering cap of the upper milling. | Plastic material | Place in the slot between sash and frame.          | 4x30 mm screws.               |
| Cap and glider for rear upper guide  | <b>5</b> |  |                  |  |                               |
| 2 mm adapter for fixed sash          | <b>6</b> | Adapter for the fixed sash fastening.  | Plastic material | -  | To be inserted.               |

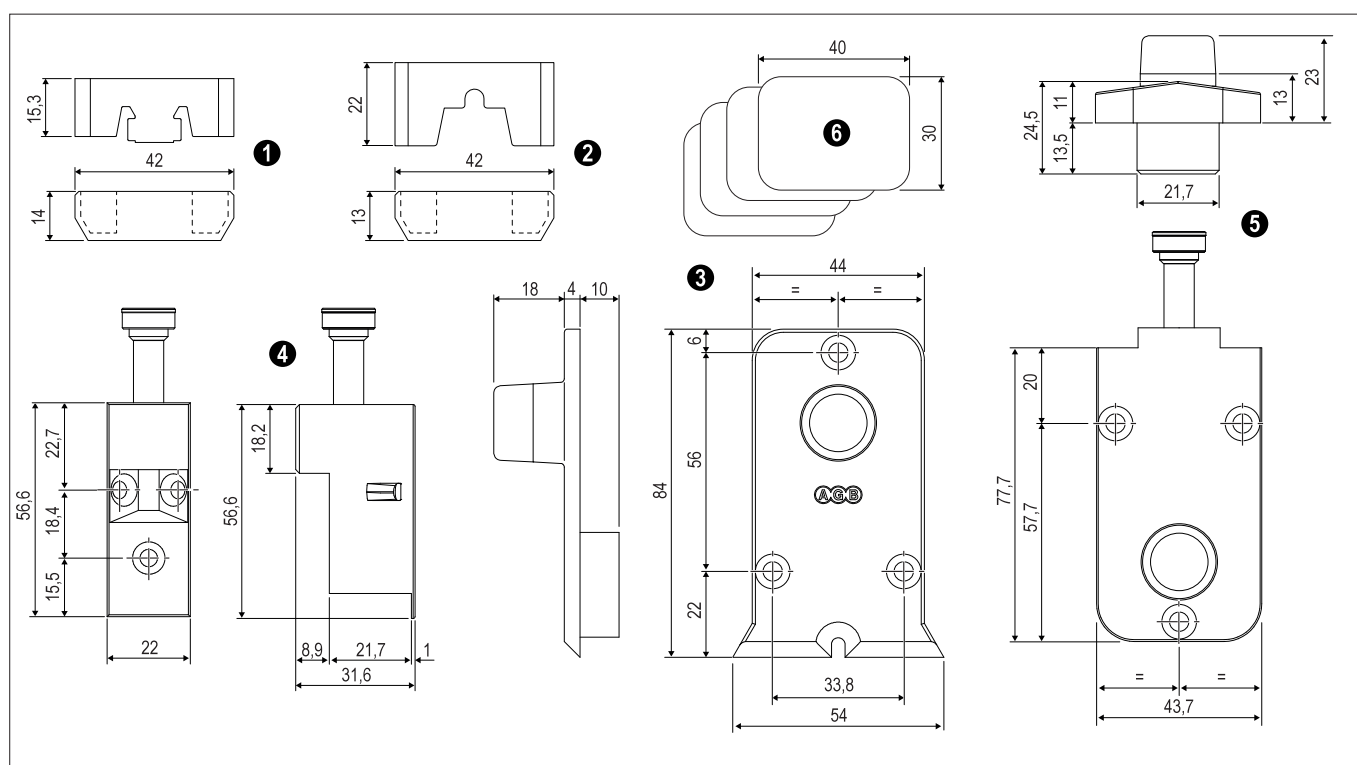

## Caps kit for embedded upper guide 22x13 - low rail

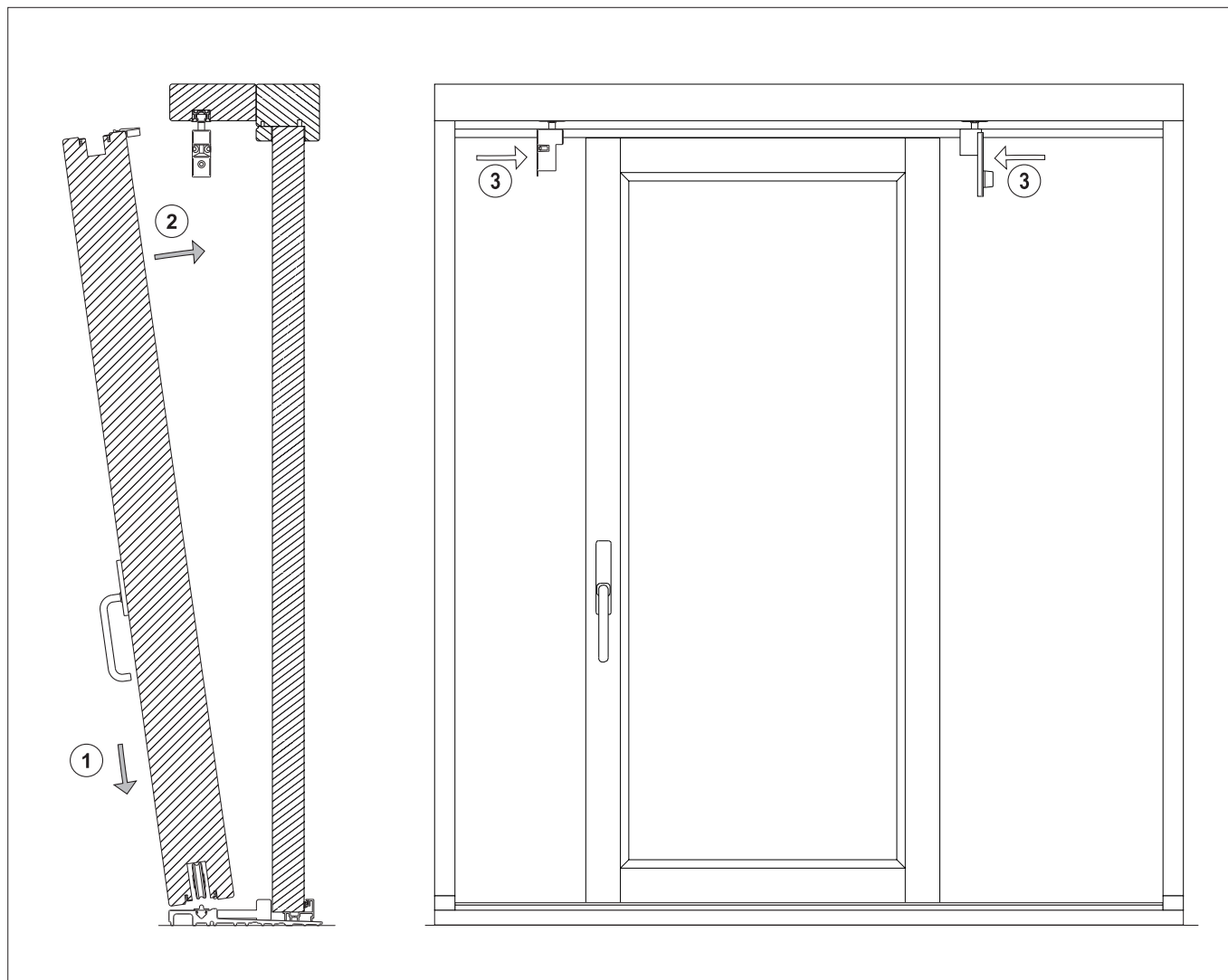

- ① Place the sash on the rail with the carriages in opening position;
- ② Place the sash in vertical position;
- ③ Fasten the gliders on the sliding sash.

| Article  | Grey RAL 7038 | Black        |
|--|---------------|--------------|
| Caps kit for embedded upper guide 22x13 (Imago) - Low rail | G00223.01.86  | G00223.01.93 |

# 330 kg carriages kit, 440 kg supplementary carriages kit, carriages connecting rod

| Article   | Ref. | Description   | Material         | Use   | Fastening        |
|---|------|---|------------------|---|------------------|
| Carriages kit, 300 kg                               | ❶    | Two carriages (front and rear, non-handed) with lift device and lever and rings.<br>The connection between the two carriages is provided by the through cuttable rod.<br>The hooking of the connecting rod is guaranteed by locking grubs with milled base to avoid possible loosening. | Steel            | Sliding sashes of weight $\leq 330$ Kg                                    | Screws 4,5x35 mm |
| Carriages kit, 300 kg with adjustable rear carriage | ❷    | Standard front carriage; rear carriage with +3,5 mm in height.  |                  |   |                  |
| Supplementary carriages kit                         | ❸    | Two carriages with lift device. Each carriage has to be coupled to a carriage of the 330 kg kit (front and rear) through connecting rod and locking grubs.  | Steel            | Sliding sashes of weight $\geq 330$ Kg and $\leq 440$ kg                  | Screws 4,5x35 mm |
| Carriages connecting rod                            | ❹    | It ensures the connection between a carriage and the other and transfers the movement of opening/closing.   | Steel            | Cuttable 1 piece  | Grubs provided   |
| Bumper / support                                    | ❺    | It allows to download the carriage weight from the sash to the snap-in rail; suitable for aluminium systems where the sash weight in closing position can't be downloaded to the gaskets.   | Plastic material | 1 for each carriage   | Snap-in rail     |
| Rod guide   | ❻    | Inserted into the carriage milling, it ensures the correct operation of connecting rod.   | Plastic material | 1 for each sliding sash   | Screws 4x30 mm   |
| Anti-derailed adapter                               | ❼    | Dedicated zamak adapter that prevents the derailing movement of sliding sash carriages after forces which are orthogonal to the sliding axis (e.i. weather conditions).   | Zamak            | Install 2 devices on each central sash; install 1 block on each side sash | Screws 4x30 mm   |

**Note.** Level the glass in order to download the weight evenly in correspondence to the carriages.

**Note.** Please don't distribute the supplementary carriages along the sash but install them coupling the main carriages.

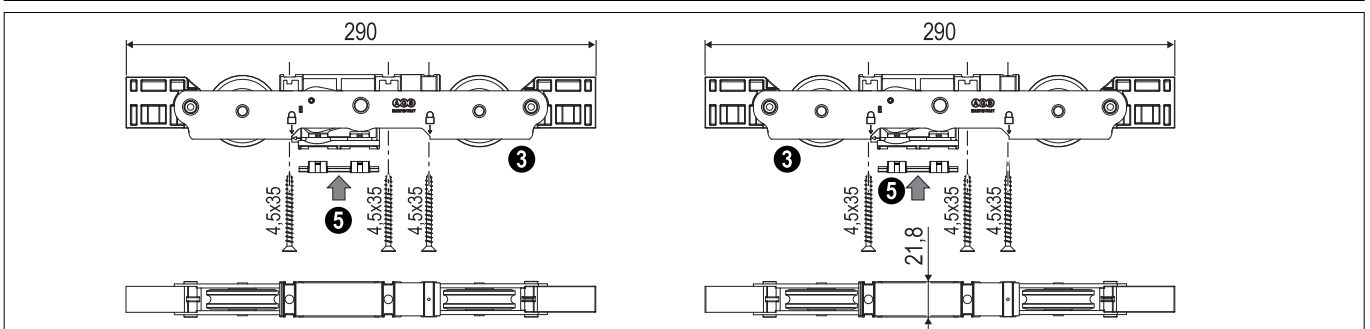
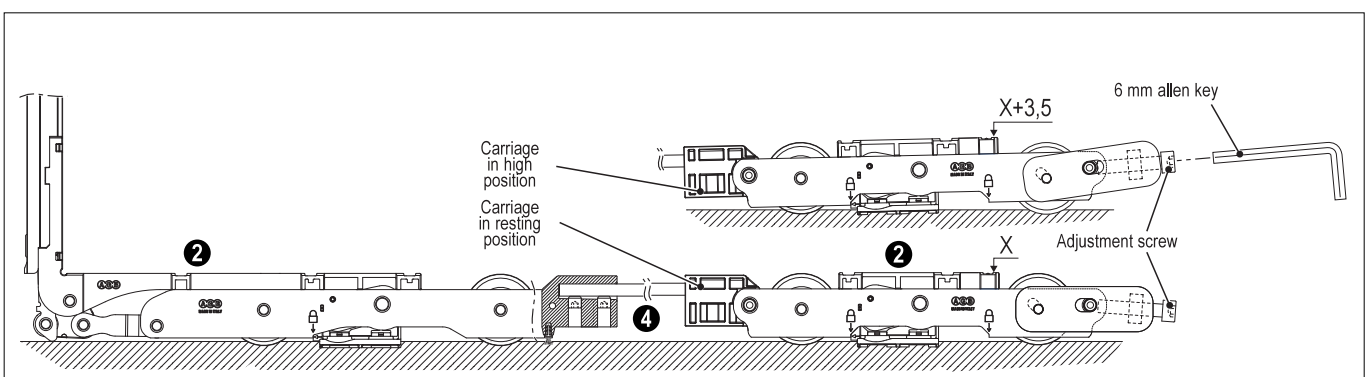
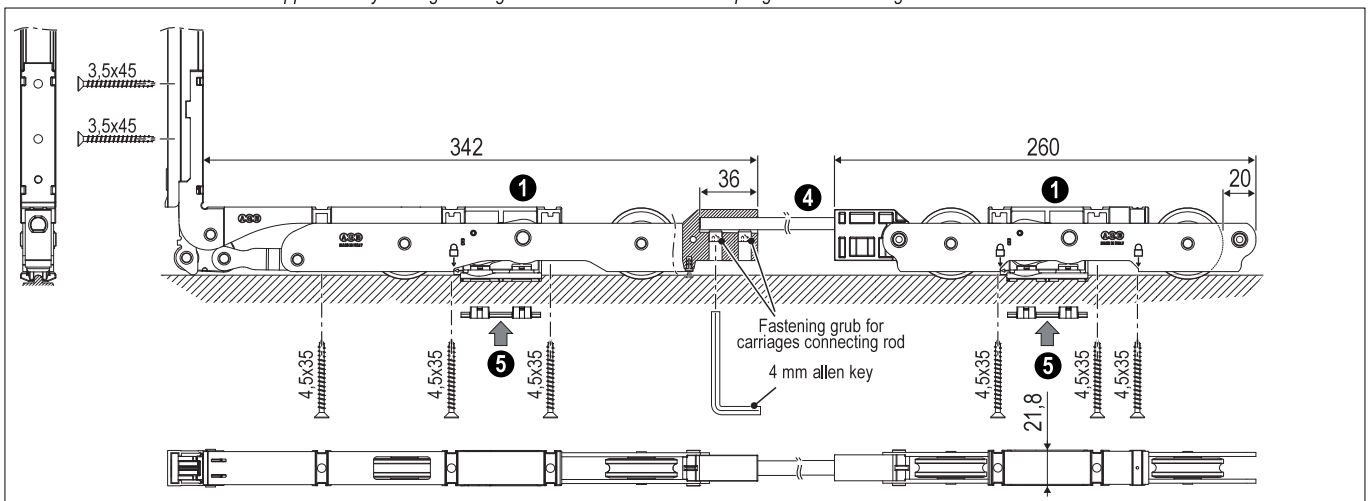



# 330 kg carriages kit, 440 kg supplementary carriages kit, carriages connecting rod

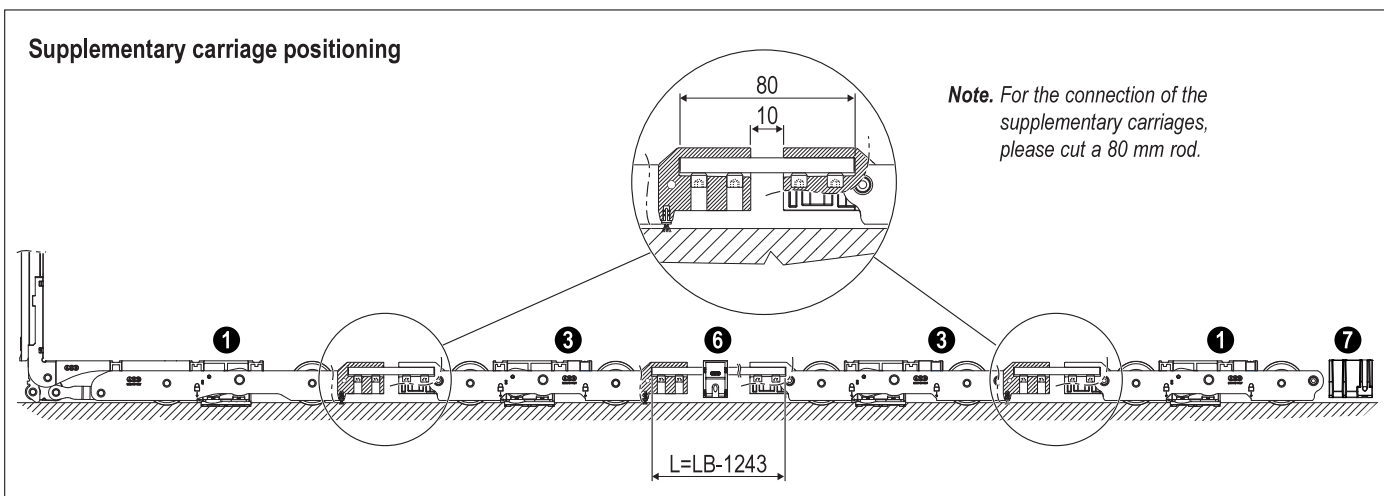
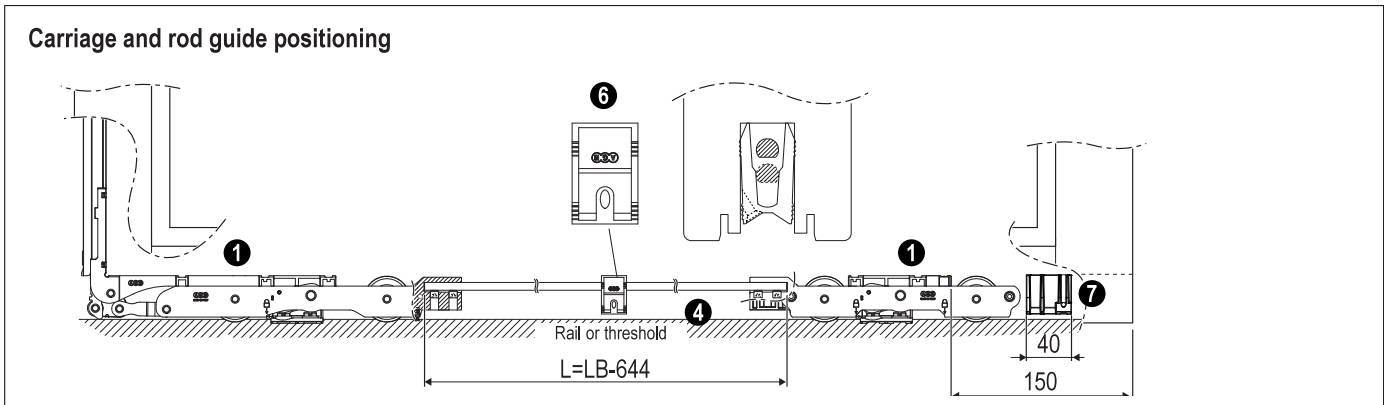
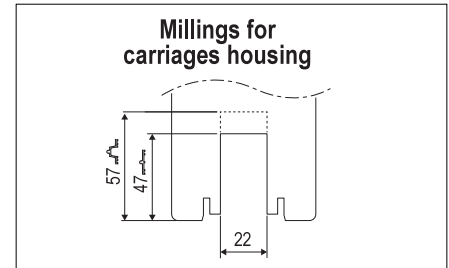
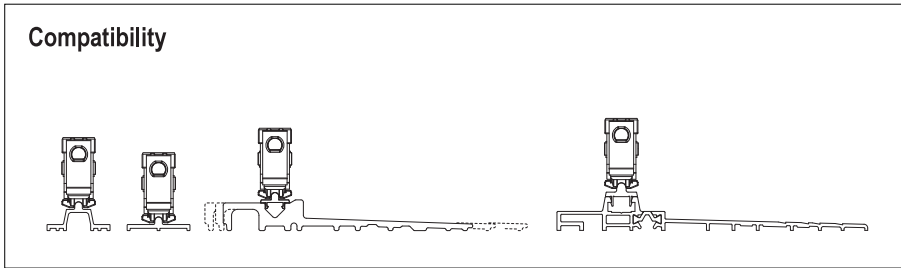

| Application fields       |         |         |                                       |         |
|--------------------------|---------|---------|---------------------------------------|---------|
| Carriages connecting rod | 330 Kg  |         | 440 Kg (with supplementary carriages) |         |
|                          | Min. SW | Max. SW | Min. SW                               | Max. SW |
| 1000                     | 645     | 1644    | 1245                                  | 2083    |
| 1400                     |         | 2044    |                                       | 2483    |
| 1800                     |         | 2444    |                                       | 2883    |
| 2700                     |         | 3344    |                                       | 3783    |

| Ref. | Description  | Code         | Length |
|------|--|--------------|--------|
| 1    | Carriages kit, 330 kg                                | G04104.00.00 | -      |
| 2    | Carriages kit, 330 kg, with adjustable rear carriage | G04114.00.00 | -      |
| 3    | Supplementary carriages kit (440 kg)                 | G04108.00.00 | -      |
| 4    | Carriage connecting rod                              | G04601.00.01 | 1000   |
|      |  | G04601.00.02 | 1400   |
|      |  | G04601.00.03 | 1800   |
|      |  | G04601.00.04 | 2700   |

| Ref. | Description          | Code         |
|------|----------------------|--------------|
| 5    | Bumper - support     | G01437.00.86 |
| 6    | Rod guide            | G05102.00.00 |
| 7    | Anti-derailed device | G01611.02.00 |

# 250 kg XC S-Line carriages kit, 400 kg XC S-Line supplementary carriages kit, XC carriages connecting rod

| Article                                      | Ref. | Description  | Material         | Use  | Fastening        |
|--|------|--|------------------|--|------------------|
| Carriages kit, XC S-Line 250 Kg              | ①    | Two carriages (front and rear, non-handed) with lift device and lever and rings. The connection between the two carriages is provided by the through cuttable rod. The hooking of the connecting rod is guaranteed by locking grubbs with milled base to avoid possible loosening. | Steel            | Sash weight $\leq$ 250 Kg  | Screws 4,5x35 mm |
|  | ②    | The adapters allow the carriages assembly on 18 and 22 mm millings.  | Plastic material | Use to install the carriages on 18 and 22 mm millings  | Clip             |
| Supplementary carriages kit XC S-Line 400 kg | ③    | Two carriages with lever lifting device and guides. Each carriage has to be coupled with one of the XC S-Line carriages kit (front and rear) by connecting rod and fastening grubbs.   | Steel            | Sash weight $>$ 250 Kg and $\leq$ 400 kg   | Screws 4,5x35 mm |
| Connecting rod                               | ④    | It ensures the connection between a carriage and the other and transfers the movement of opening/closing.  | Steel            | Cut 1 piece  | Grubs provided   |
| Stop / support                               | ⑤    | It allows to download the carriage weight from the sash to the snap-in rail; suitable for aluminium systems where the sash weight in closing position can't be downloaded to the gaskets.  | Plastic material | 1 for each carriage  | Snap-in rail     |
| Rod guide                                    | ⑥    | Inserted into the carriage milling, it ensures the correct operation of connecting rod.  | Plastic material | 1 for each sliding sash. Do not use on 16 mm width milling.  | Screws 4x30 mm   |
| Anti-derailed adapter                        | ⑦    | Dedicated zamak device that prevents the carriages derailment of the sliding sash after orthogonal pushes on the sliding axis (for example weather agents).  | Zamak            | Install 2 blocks on each central sash; install 1 block on each side sash. Do not use on 16 mm width milling. | Screws 4x30 mm   |

**Note.** Level the glass in order to download the weight evenly in correspondence to the carriages.

**Note.** Please don't distribute the supplementary carriages along the sash but install them coupling the main carriages.

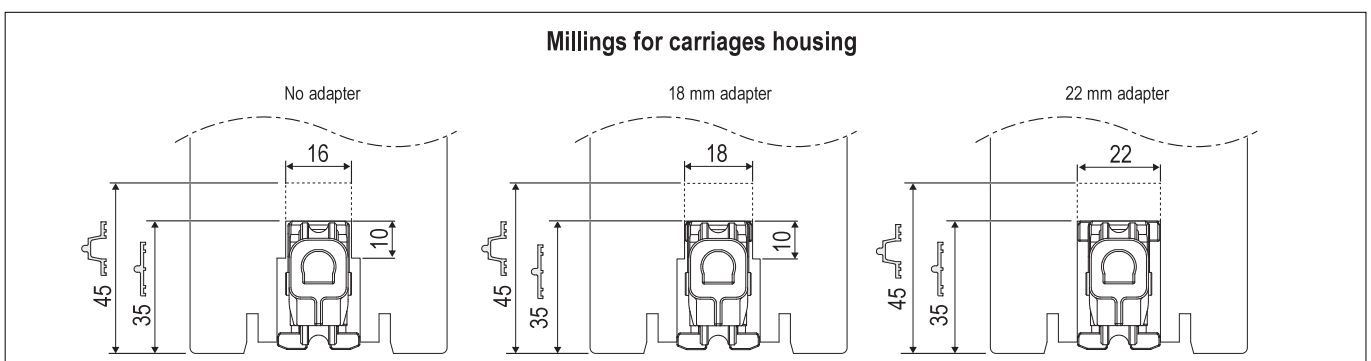
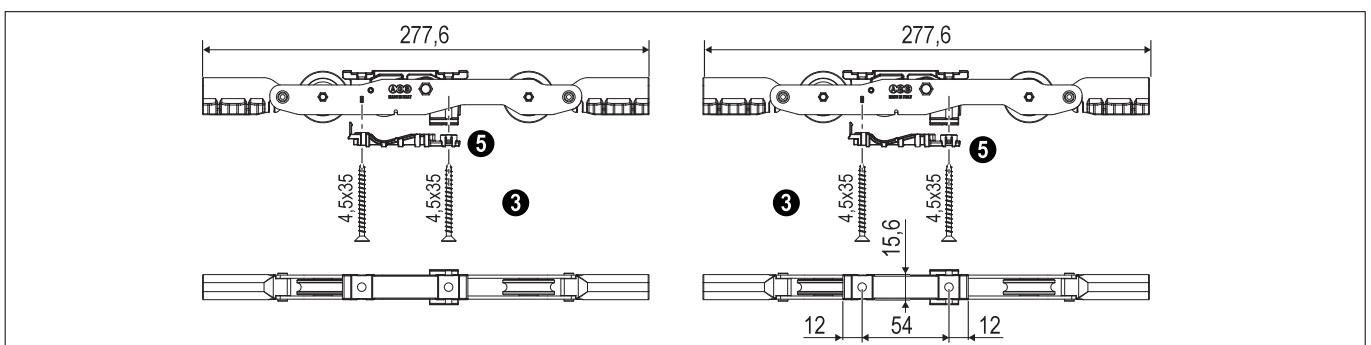
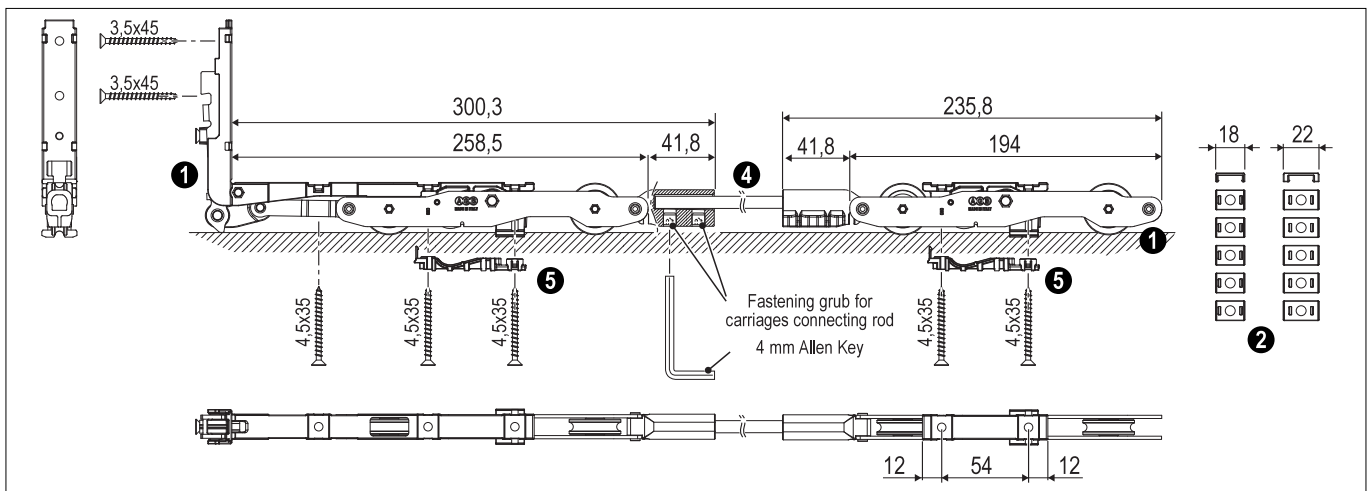

# 250 kg XC S-Line carriages kit, 400 kg XC S-Line supplementary carriages kit, XC carriages connecting rod

## Compatibility

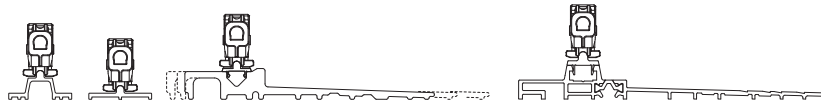

## Carriage and rod guide positioning

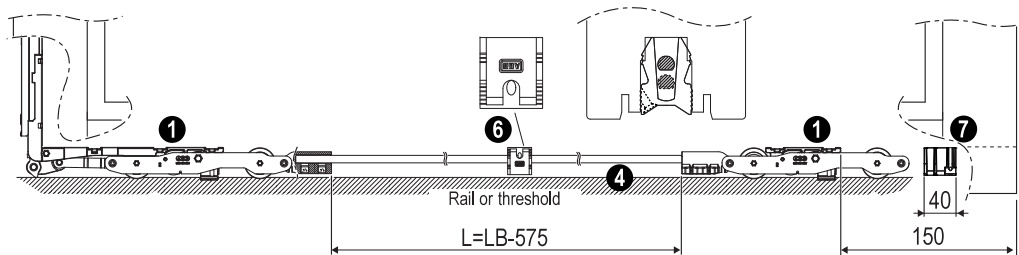

## Supplementary carriage positioning

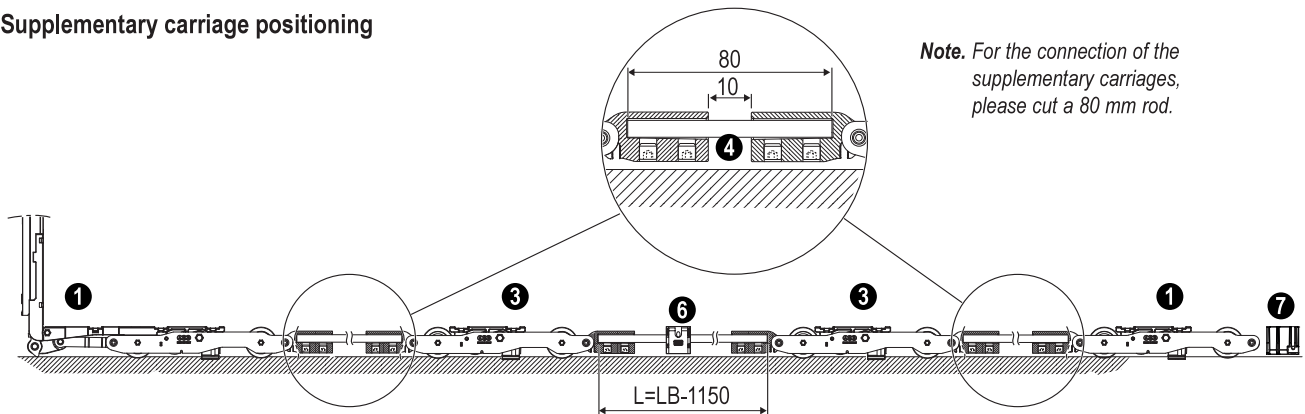

## Application fields

| Length of connecting rod | 250 Kg  |         | 400 Kg<br>(with supplementary carriages) |         |
|--------------------------|---------|---------|--|---------|
|                          | Min. SW | Max. SW | Min. SW                                  | Max. SW |
| 1000                     | 580     | 1575    | 1160                                     | 1990    |
| 1400                     |         | 1975    |  | 2390    |
| 1800                     |         | 2375    |  | 2790    |
| 2700                     |         | 3275    |  | 3690    |

| Ref. | Description                        | Code         | Length |
|------|------------------------------------|--------------|--------|
| 1    | 250 kg carriages kit               | G04109.00.00 | -      |
| 3    | 400 kg supplementary carriages kit | G04110.00.00 | -      |
| 4    | Carriage connecting rod            | G04601.00.01 | 1000   |
|      |                                    | G04601.00.02 | 1400   |
|      |                                    | G04601.00.03 | 1800   |
|      |                                    | G04601.00.04 | 2700   |

| Ref. | Description          | Code         | Length |
|------|----------------------|--------------|--------|
| 5    | Bumper - support     | G02142.00.XX | -      |
| 6    | Rod guide            | G05104.00.00 | -      |
| 7    | Anti-derailed device | G01611.01.00 | -      |

# Locking profiles for lateral point and extension

| Article   | Description   | Material  | Use   | Fastening        |
|---|---|-----------|---|------------------|
| <b>1</b> Pre-drilled locking profile (2 suitable seats)   | Locking profile in anodised aluminium with suitable holes for housing the hook strikers.<br><b>Note.</b> <i>Not suitable for striker with signal system.</i>                    | Aluminium | On lateral point of lift&slide systems, coupled to the lock | Screws 4,5x45 mm |
| <b>2</b> Pre-drilled locking profile (3 suitable seats)   |   |           |   |                  |
| <b>3</b> Pre-drilled locking profile (3 suitable seats, the one in the middle for striker with signal system) | Locking profile in anodised aluminium with suitable holes for housing the hook strikers.<br><b>Note.</b> <i>The central housing is suitable for striker with signal system.</i> |           |   |                  |
| <b>4</b> Locking profile extension  | Installed above the locking profile, it allows the extension of the application field and the addition of a locking point.  |           |   |                  |

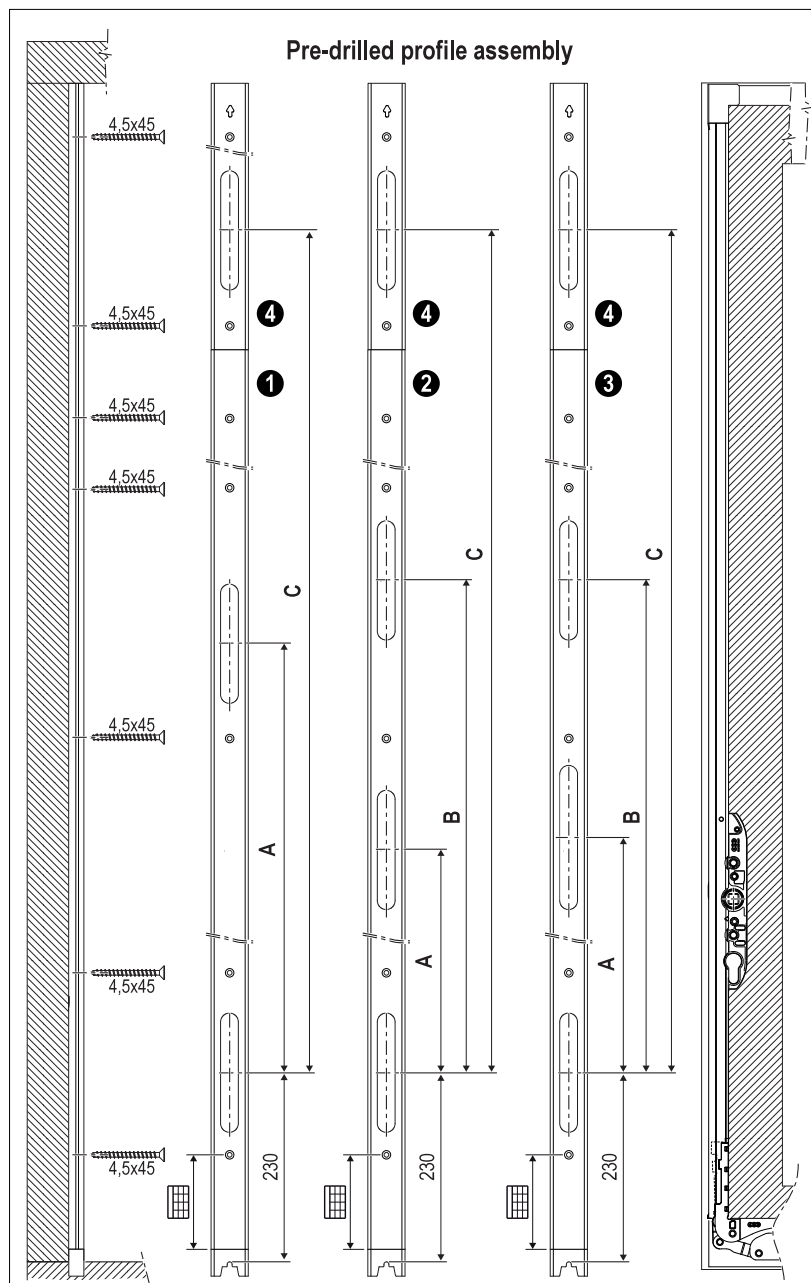
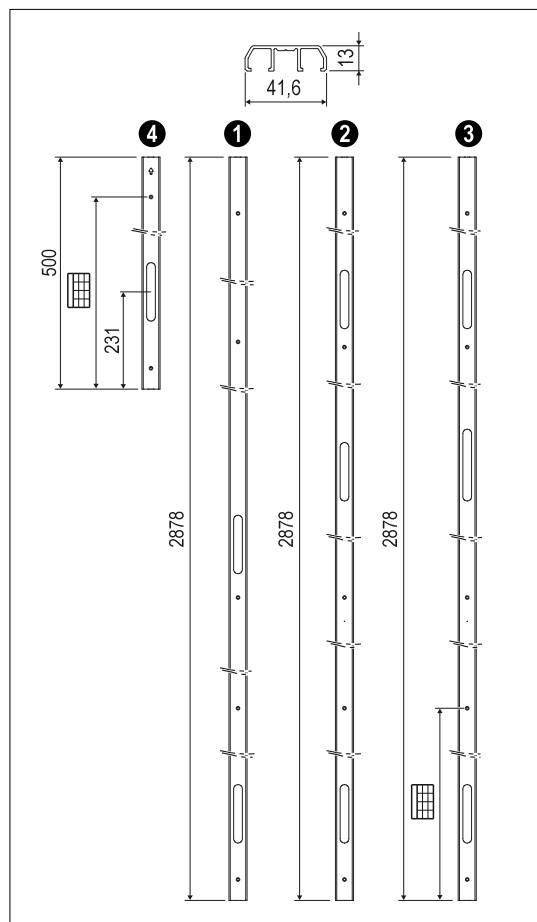

| Locking points position |    |                        |        |      |               |
|-------------------------|----|------------------------|--------|------|---------------|
|                         | GR | Locking profile height | A      | B    | C (min - max) |
| <b>1</b>                | 3  | 2878                   | 1354   | -    | 1789,5+2137,5 |
|                         | 4  | 2878                   | 1504   | -    | 1939,5+2387,5 |
|                         | 5  | 2878                   | 1904   | -    | 2339,5+2737,5 |
| <b>2</b>                | 3  | 2878                   | 970    | 1354 | 1789,5+2137,5 |
|                         | 4  | 2878                   | 970    | 1504 | 1939,5+2387,5 |
|                         | 5  | 2878                   | 970    | 1904 | 2339,5+2737,5 |
| <b>3</b>                | 3  | 2878                   | 1042,6 | 1354 | 1789,5+2137,5 |
|                         | 4  | 2878                   | 1042,6 | 1504 | 1939,5+2387,5 |
|                         | 5  | 2878                   | 1042,6 | 1904 | 2339,5+2737,5 |

| Article   | GR | Article code, in Silver | Article code, in Electrocolour | Length | SH        | Suitable seats for striker |
|---|----|-------------------------|--------------------------------|--------|-----------|----------------------------|
| <b>1</b> Pre-drilled locking profile (2 suitable seats)   | 3  | G01359.03.01            | G01359.03.02                   | 2878   | 1770-2900 | 2                          |
|   | 4  | G01359.04.01            | G01359.04.02                   |        |           |                            |
|   | 5  | G01359.05.01            | G01359.05.02                   |        |           |                            |
| <b>2</b> Pre-drilled locking profile (3 suitable seats)   | 3  | G01359.13.01            | G01359.13.02                   | 2878   | 1770-2900 | 3                          |
|   | 4  | G01359.14.01            | G01359.14.02                   |        |           |                            |
|   | 5  | G01359.15.01            | G01359.15.02                   |        |           |                            |
| <b>3</b> Pre-drilled locking profile (3 suitable seats, the one in the middle for striker with signal system) | 3  | G01359.23.01            | G01359.23.02                   | 2878   | 1770-2900 | 2+1                        |
|   | 4  | G01359.24.01            | G01359.24.02                   |        |           |                            |
|   | 5  | G01359.25.01            | G01359.25.02                   |        |           |                            |
| <b>4</b> Locking profile extension  | -  | G01360.01.01            | G01360.01.02                   | 500    | 2900+500  | 1                          |

| Screw holes position |    |     |     |      |      |      |
|----------------------|----|-----|-----|------|------|------|
|                      | GR | 1°  | 2°  | 3°   | 4°   | 5°   |
| <b>1</b>             | 3  | 48  | 748 | 1448 | 2148 | 2718 |
| <b>2</b>             | 4  | 48  | 748 | 1448 | 2148 | 2718 |
| <b>3</b>             | 5  | 48  | 748 | 1448 | 2018 | 2718 |
| <b>4</b>             | -  | 128 | 338 | -    | -    | -    |

# Pin holder profile for lateral point

| Article                     | Description   | Material  | Use  | Fastening        |
|-----------------------------|---|-----------|--|------------------|
| Pre-drilled locking profile | Pin holder profile in anodised aluminium with suitable holes for pins housing. Caps for unused holes. | Aluminium | Lateral point of Lift&Slide systems coupled to the lock. | 4,5x45 mm screws |

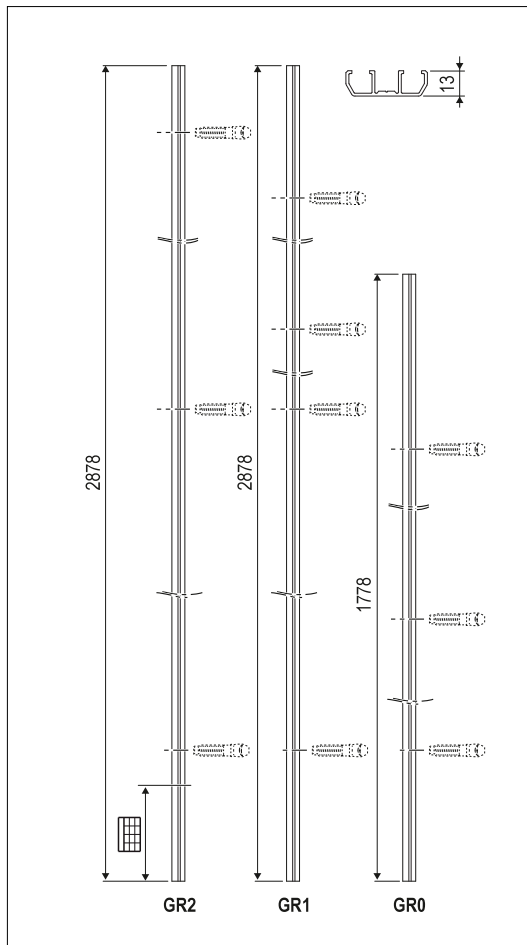

| Screw holes position |     |     |      |      |      |
|----------------------|-----|-----|------|------|------|
| GR                   | 1°  | 2°  | 3°   | 4°   | 5°   |
| 0                    | 48  | 748 | 1448 |      |      |
| 1                    | 48  | 748 | 1448 | 2148 | 2718 |
| 2                    | 160 | 730 | 1430 | 2130 | 2830 |

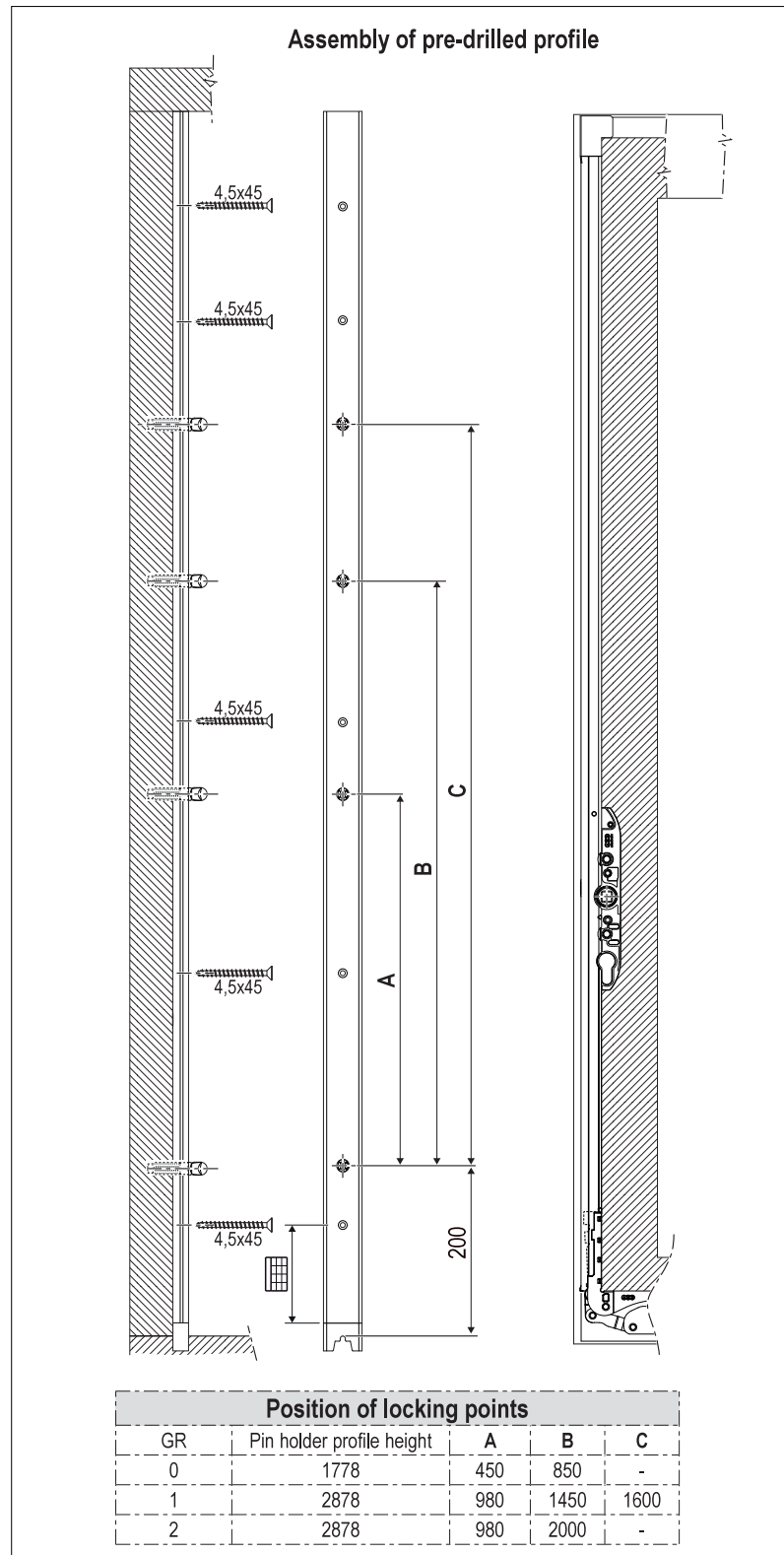

| Article                     | GR | Article code, in Silver | Article code, in Electrocolour | Length | SH        |
|-----------------------------|----|-------------------------|--------------------------------|--------|-----------|
| Pre-drilled locking profile | 0  | For lock GR1 and GR2    | G01341.00.01 / G01341.00.02    | 1778   | 800-1800  |
|                             | 1  | For lock GR3 and GR4    | G01341.01.01 / G01341.01.02    | 2878   | 1770-2900 |
|                             | 2  | For lock GR5            | G01341.02.01 / G01341.02.02    | 2878   | 1770-2900 |

# Locking profile pins for coaxial sashes and dedicated extensions

| Article  | Description   | Material                          | Use                             | Fastening   |
|--|---|-----------------------------------|---------------------------------|---|
| Locking profile kit for coaxial sashes with end caps | ① Locking profile with pre-assembled anti-burglar pins. Thanks to specific end caps (lower and upper), it ensures the perfect insulation in critic areas of systems with coaxial sashes (low side and high side of central point). It replaces the wooden clamp with a great time saving for window workings. | Profile: aluminium<br>Pins: steel | On systems with coaxial sashes. | Screws 4,5x60 mm.<br><br>The position of profile screw holes coincide exactly with lock screw holes which are free. |
| Locking profile extension for coaxial sashes         | ② Extension for locking profile available with or without pin.  |                                   |                                 |   |

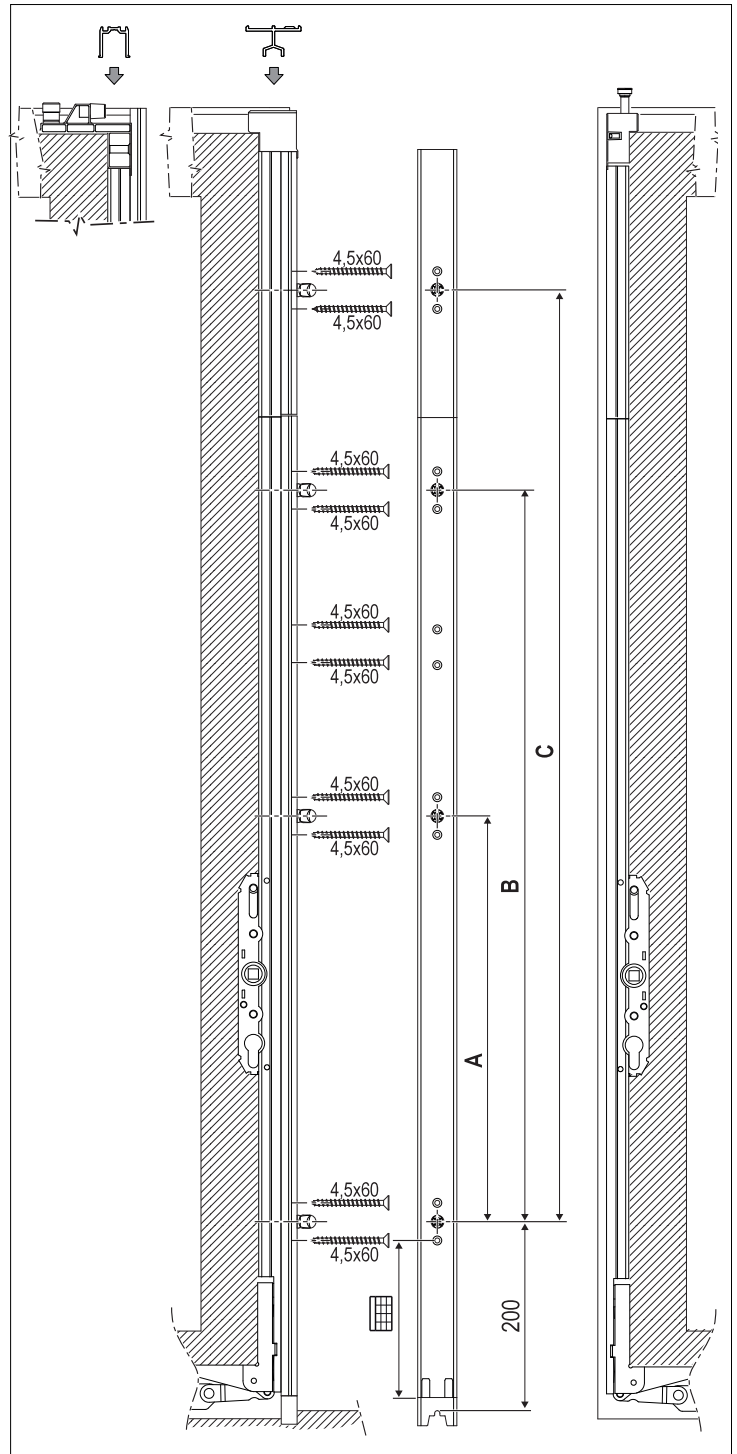
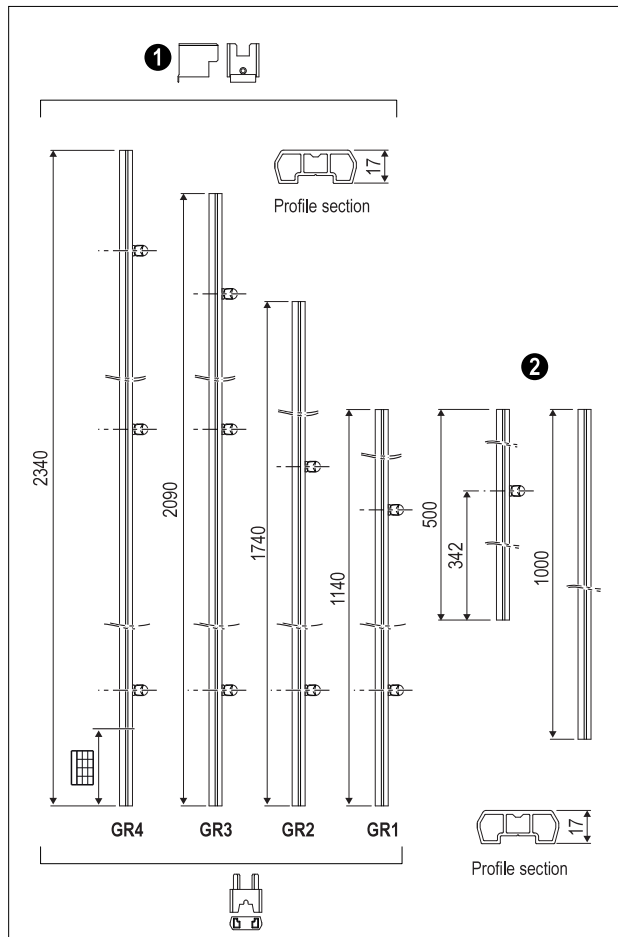

| Screw holes positioning |     |     |     |     |      |      |      |      |
|-------------------------|-----|-----|-----|-----|------|------|------|------|
| GR                      | 1°  | 2°  | 3°  | 4°  | 5°   | 6°   | 7°   | 8°   |
| 1                       | 132 | 232 | 294 | 512 | 582  | 682  |      |      |
| 2                       | 132 | 232 | 294 | 512 | 982  | 1082 |      |      |
| 3                       | 132 | 232 | 832 | 894 | 1112 | 1212 | 1582 | 1682 |
| 4                       | 132 | 232 | 832 | 894 | 1112 | 1212 | 1732 | 1832 |

| Position of locking points |                           |     |      |               |
|----------------------------|---------------------------|-----|------|---------------|
| GR                         | Pin holder profile height | A   | B    | C *           |
| 1                          | 1140                      | 450 | -    | 783,5-1283,5  |
| 2                          | 1740                      | 850 | -    | 1183,5-1883,5 |
| 3                          | 2090                      | 980 | 1450 | 1783,5-2233,5 |
| 4                          | 2340                      | 980 | 1600 | 1933,5-2483,5 |

\* Achievable only with 500 mm extension

| Article  | GR | Article code, in Silver | Article code, in Electrocolour | SRH       | Handle height | Lock height |
|--|----|-------------------------|--------------------------------|-----------|---------------|-------------|
| ① Locking profile kit for coaxial sashes with end caps | 1  | G01757.01.01            | G01757.01.02                   | 810-1200  | 400/410       | 1124        |
|  | 2  | G01757.02.01            | G01757.02.02                   | 1170-1800 | 400/410       | 1724        |
|  | 3  | G01757.03.01            | G01757.03.02                   | 1770-2150 | 1000/1010     | 2074        |
|  | 4  | G01757.04.01            | G01757.04.02                   | 1920-2400 | 1000/1010     | 2324        |

| Ref. | Article               | Article code, in Silver | Article code, in Electrocolour | Length |
|------|-----------------------|-------------------------|--------------------------------|--------|
| ②    | Extension with pin    | G01757.97.01            | G01757.97.02                   | 500    |
|      | Extension without pin | G01757.00.01            | G01757.00.02                   | 1000   |

# Gas spring kit and sensors

| Article        | Ref.     | Description   | Use  | Fastening   |
|----------------|----------|---|--|---|
| Gas spring kit | <b>1</b> | Gas cylinder that helps the sash opening movement (lifting) and reduce the speed of the handle. | Apply in suitable holes into the movable rod and in the aluminium profile of the lock. Please use with sashes of weight $\geq 200$ Kg. | Screws are provided.<br><b>Note.</b> Please assemble the gas spring with lock in opening position and lying spring. |
| Sensors        | <b>2</b> | Magnet and sensor for the control of opening.   | Apply the magnet in the suitable hole of the movable rod and the sensor in the hole to realise the pin holder profile.                 | To joint  |
| Magnet         | <b>3</b> | Magnet with clip for lock.  | Apply the magnet in the dedicated hole of the movable rod.   | With clip   |

### Gas spring installation

Fasten the carriages and the connecting rod to the carriages.  
Unlock the carriages and put them in opening position.  
Assemble the lock (with gas spring) in opening position.

**1**

**2**

**3**

Place the kit in specific holes under the handle

Identification of dedicated holes

Assembly order

**1**

### Installation of reed sensors

Find the point where the sensor and the magnet have to be installed

Please make a hole  $\varnothing 12$  mm (aluminium pin holder profile)

Please make a hole  $\varnothing 12$  mm (wooden pin holder profile)

**2**

**2**

**3**

**3**

| Ref.     | Article        | Article code |
|----------|----------------|--------------|
| <b>1</b> | Gas spring kit | GMG702.04.00 |

| Ref.     | Article      | Article code | Colour |
|----------|--------------|--------------|--------|
| <b>2</b> | Sensor + cap | G05006.00.86 | Grey   |
|          |              | G05006.00.93 | Black  |

| Ref.     | Article        | Article code |
|----------|----------------|--------------|
| <b>3</b> | Magnet on clip | G05003.00.00 |

# 440 Kg locks and specific extensions

| Article          | Ref. | Description  | Material                        | Use   | Fastening                                      |
|------------------|------|--|---------------------------------|---|--|
| Locks, 440 Kg    | ❶    | 10 mm handle hub with radius corner, hole for European cylinder housing. | Forend: aluminium<br>Rod: steel | Choose the lock according to the jamb width and the sliding sash height. Backsets available: 27,5 and 37,5 mm in 5 different heights (see the table). | 4,5x45 mm screws<br>★ For Imago+ use 4,5x40 mm |
| Lock extension   | ❷    | -  | Forend: aluminium<br>Rod: steel | It gives the possibility to add a locking point.  | 4,5x45 mm screws<br>★ For Imago+ use 4,5x40 mm |
| Covering profile | ❸    | -  | Aluminium                       | It covers the milling.  | 4,5x45 mm screws<br>★ For Imago+ use 4,5x40 mm |

| Screw hole position |    |       |       |       |        |        |        |        |
|---------------------|----|-------|-------|-------|--------|--------|--------|--------|
| GR                  | 1° | 2°    | 3°    | 4°    | 5°     | 6°     | 7°     | 8°     |
| 1                   | 17 | 100,5 | 208,5 | 480,5 | 550,5  | 658,5  |        |        |
| 2                   | 17 | 100,5 | 208,5 | 480,5 | 950,5  | 1058,5 |        |        |
| 3                   | 17 | 100,5 | 208,5 | 808,5 | 1080,5 | 1188,5 | 1550,5 | 1658,5 |
| 4                   | 17 | 100,5 | 208,5 | 808,5 | 1080,5 | 1188,5 | 1700,5 | 1808,5 |
| 5                   | 17 | 100,5 | 208,5 | 808,5 | 1080,5 | 1188,5 | 2100,5 | 2208,5 |

**Backset 27,5**

**Backset 37,5**



# 440 Kg locks and specific extensions

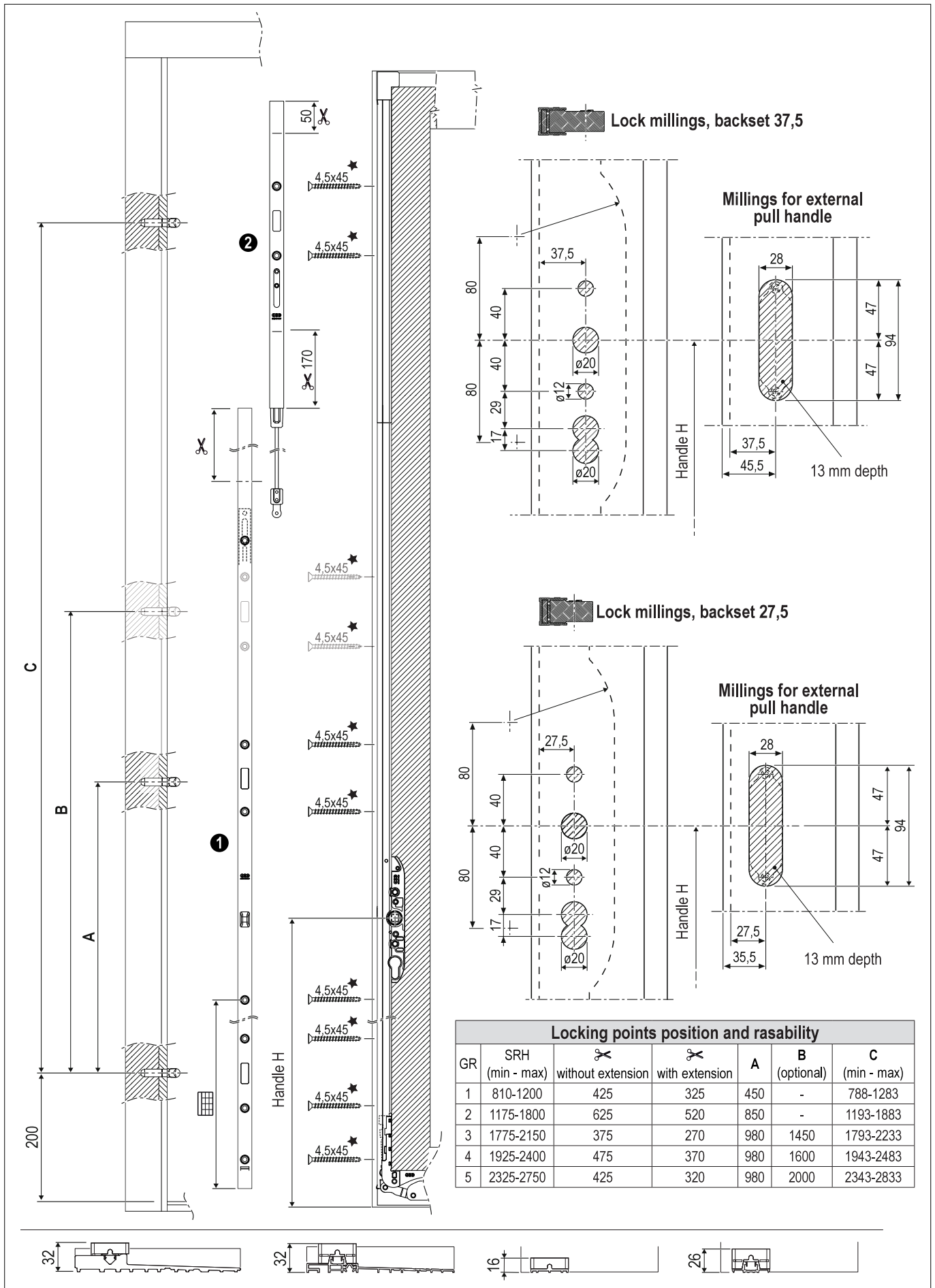

## 440 Kg locks and specific extensions

| Ref.     | Article                     | GR | Article code,<br>in Silver | Article code,<br>in Electrocolour | SRH $\diamond$ | Handle height | Lock height |
|----------|-----------------------------|----|----------------------------|-----------------------------------|----------------|---------------|-------------|
| <b>1</b> | Lock 440 Kg<br>Backset 27,5 | 1  | G04027.01.01               | G04027.01.02                      | 810-1200       | 400/410       | 1096        |
|          |                             | 2  | G04027.02.01               | G04027.02.02                      | 1175-1800      | 400/410       | 1696        |
|          |                             | 3  | G04027.03.01               | G04027.03.02                      | 1775-2150      | 1000/1010     | 2046        |
|          |                             | 4  | G04027.04.01               | G04027.04.02                      | 1925-2400      | 1000/1010     | 2296        |
|          |                             | 5  | G04027.05.01               | G04027.05.02                      | 2325-2750      | 1000/1010     | 2646        |
|          | Lock 440 Kg<br>Backset 37,5 | 1  | G04037.01.01               | G04037.01.02                      | 810-1200       | 400/410       | 1096        |
|          |                             | 2  | G04037.02.01               | G04037.02.02                      | 1175-1800      | 400/410       | 1696        |
|          |                             | 3  | G04037.03.01               | G04037.03.02                      | 1775-2150      | 1000/1010     | 2046        |
|          |                             | 4  | G04037.04.01               | G04037.04.02                      | 1925-2400      | 1000/1010     | 2296        |
|          |                             | 5  | G04037.05.01               | G04037.05.02                      | 2325-2750      | 1000/1010     | 2646        |

$\diamond$  With upper guide 22x22 cod. G01002.XX.XX, the SRH application field will be reduced up to 10 mm.

| Ref.     | Article                      | Article code,<br>in Silver | Article code,<br>in Electrocolour | Length |
|----------|------------------------------|----------------------------|-----------------------------------|--------|
| <b>2</b> | Extension with locking point | G04401.01.01               | G04401.01.02                      | 500    |
| <b>3</b> | Covering profile             | G04401.02.01               | G04401.02.02                      | 1000   |

# 440 Kg hook locks and specific extensions

| Article          | Ref. | Description  | Material  | Use  | Fastening                                      |
|------------------|------|--|---|--|--|
| Locks, 440 Kg    | ❶    | 10 mm handle hub with radius corner, hole for European cylinder housing. | Forend: aluminium<br>Rod: steel<br>Hooks: steel | Choose the lock according to the jamb width and the sliding sash height.<br>Backsets available: 27,5 and 37,5 mm in 3 different heights (see the table). | 4,5x45 mm screws<br>★ For Imago+ use 4,5x40 mm |
| Lock extension   | ❷    | -  | Forend: aluminium<br>Rod: steel<br>Hooks: steel | It gives the possibility to add a locking point.   | 4,5x45 mm screws<br>★ For Imago+ use 4,5x40 mm |
| Covering profile | ❸    | -  | Aluminium                                       | It covers the milling.   | 4,5x45 mm screws<br>★ For Imago+ use 4,5x40 mm |

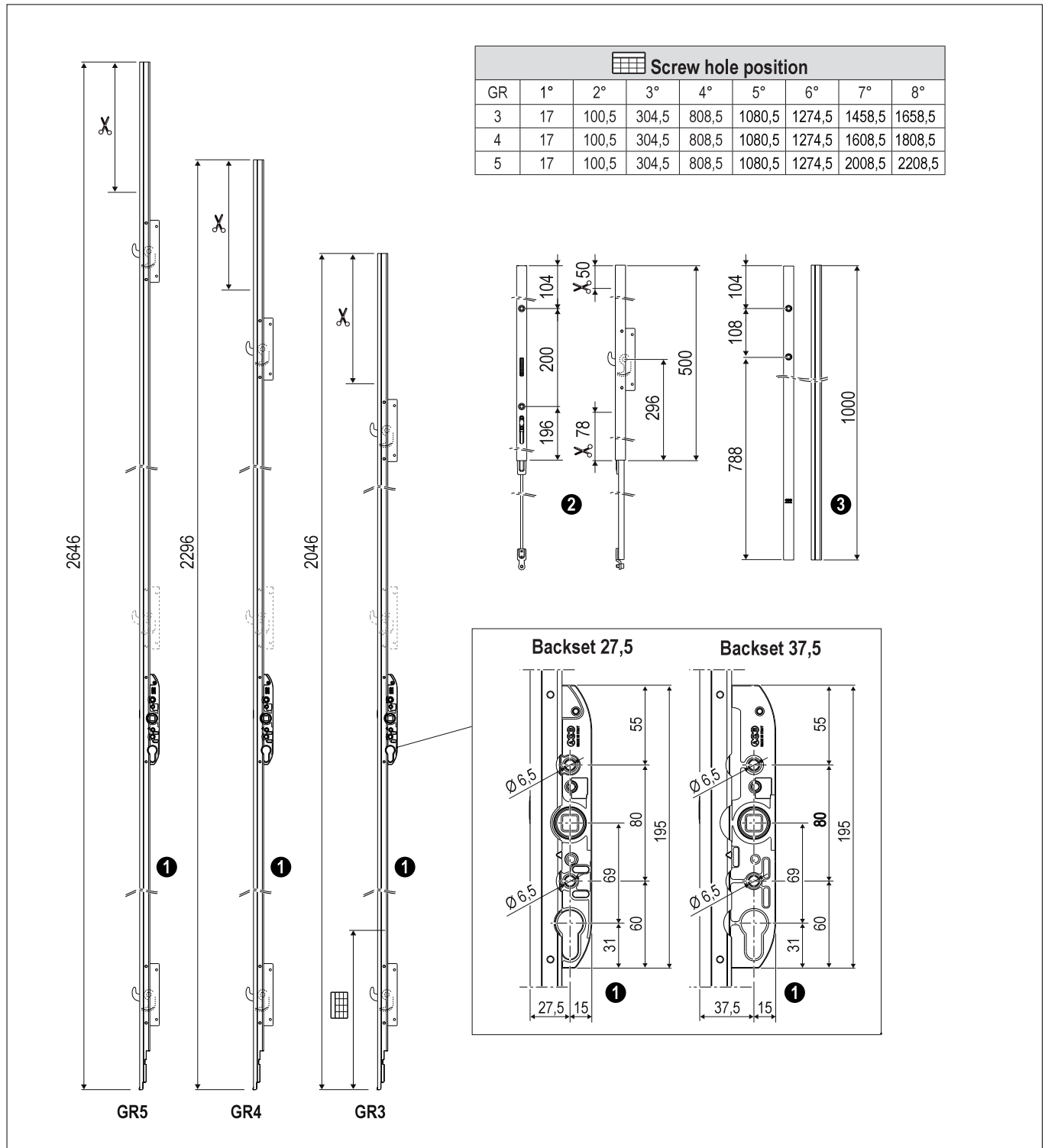



# 440 Kg hook locks and specific extensions

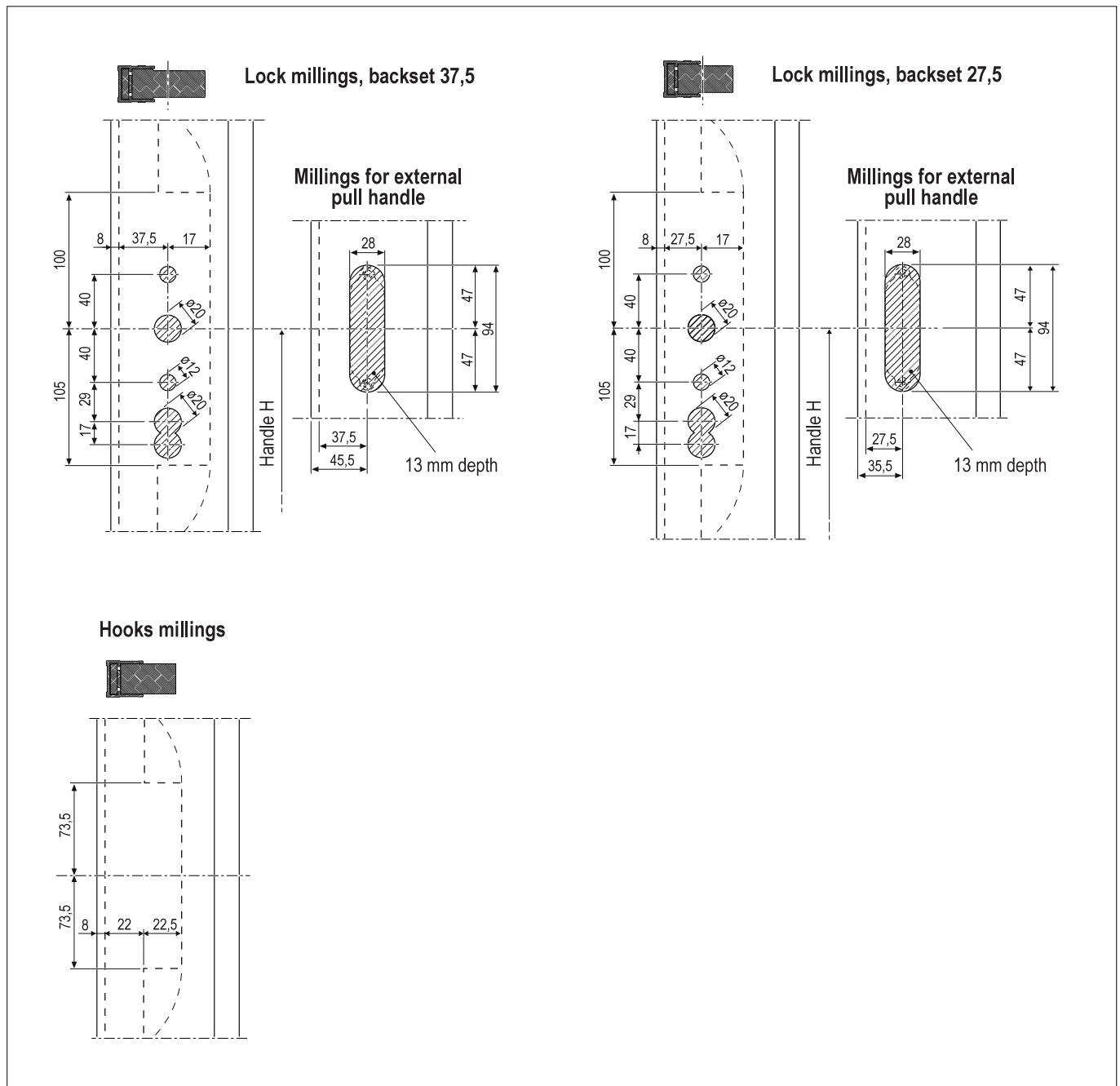

| Ref.     | Article                  | GR | Article code, in Silver | Article code, in Electrocolour | SRH $\diamond$ | Handle height | Lock height |
|----------|--------------------------|----|-------------------------|--------------------------------|----------------|---------------|-------------|
| <b>1</b> | Lock 440 Kg Backset 27,5 | 3  | G03927.03.01            | G03927.03.02                   | 1775-2150      | 1000/1010     | 2046        |
|          |                          | 4  | G03927.04.01            | G03927.04.02                   | 1925-2400      | 1000/1010     | 2296        |
|          |                          | 5  | G03927.05.01            | G03927.05.02                   | 2325-2750      | 1000/1010     | 2646        |
|          | Lock 440 Kg Backset 37,5 | 3  | G03937.03.01            | G03937.03.02                   | 1775-2150      | 1000/1010     | 2046        |
|          |                          | 4  | G03937.04.01            | G03937.04.02                   | 1925-2400      | 1000/1010     | 2296        |
|          |                          | 5  | G03937.05.01            | G03937.05.02                   | 2325-2750      | 1000/1010     | 2646        |

$\diamond$  With upper guide 22x22 cod. G01002.XX.XX, the SRH application field will be reduced up to 10 mm.

| Ref.     | Article                      | Article code, in Silver | Article code, in Electrocolour | Length |
|----------|------------------------------|-------------------------|--------------------------------|--------|
| <b>2</b> | Extension with locking point | G04600.01.01            | G04600.01.02                   | 500    |
| <b>3</b> | Covering profile             | G04401.02.01            | G04401.02.02                   | 1000   |

# Hooks

| Article  | Ref.     | Description  | Material        | Use   | Fastening  |
|--|----------|--|-----------------|---|--|
| Additional hook                                | <b>1</b> | Element with steel hook that can be placed to the lock in the defined position.                  | Steel and zamak | To add a locking point to the lock  | Using the elastic plug supplied, on suitable holes to the lock |
| Additional hook with microventilation position | <b>2</b> | Element with steel microventilation hook that can be placed to the lock in the defined position. |                 | It ensures the microventilation allowing to pull close the sash to the frame and blocking it in that position |  |

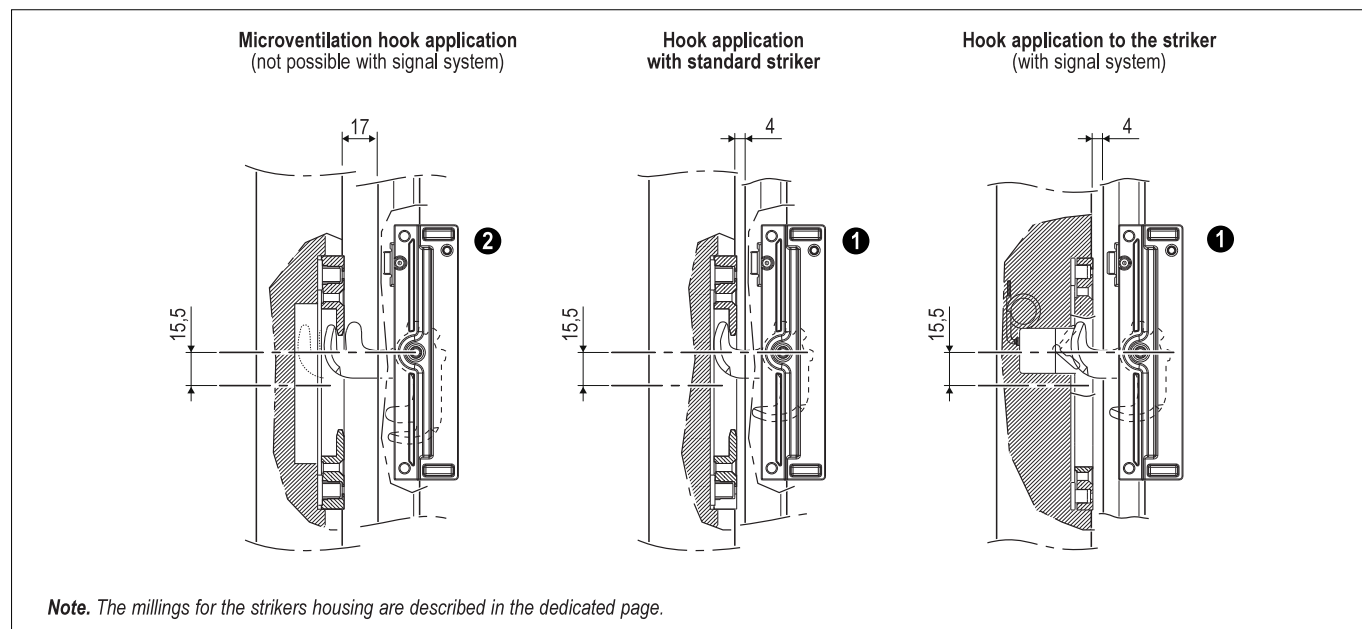
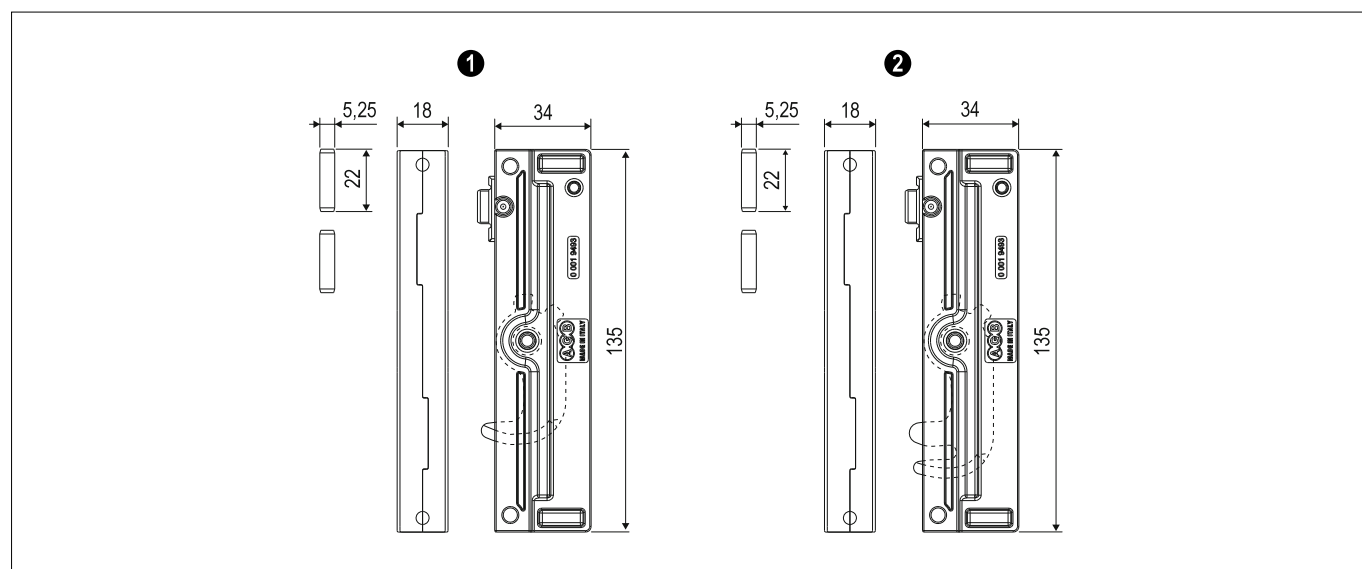

| Ref.     | Description                                    | Article      |
|----------|--|--------------|
| <b>1</b> | Additional hook                                | G05008.00.00 |
| <b>2</b> | Additional hook with microventilation position | G05010.00.00 |

# Locking pins

| Article                       | Ref.     | Description   | Material | Use   | Fastening  |
|-------------------------------|----------|---|----------|---|--|
| Locking pins                  | <b>1</b> | Steel threaded pins.  | Steel    | Fastened to the jamb of the frame, they block the sliding sashes. They are available for wood or PVC and aluminium. | <p>ø10 mm pre-hole for soft wood.<br/>ø11 mm pre-hole for hard wood.</p> <p>Fasten the pin using the suitable hook G00746.00.06.</p> <p>Attention: don't use the hammer as it will compromise the pin tightness.</p> <p><b>Note.</b> To determine the placement of locking pin, please use the jig art. G00746.00.05 (see the chapter "Jigs").</p> |
| Anti-burglar locking pins     | <b>2</b> | Steel threaded pins.  |          |   |  |
| Pin with ventilation position | <b>3</b> | Threaded pin with double locking position. It allows to close the sash to the frame with a split for ventilation. |          |   |  |

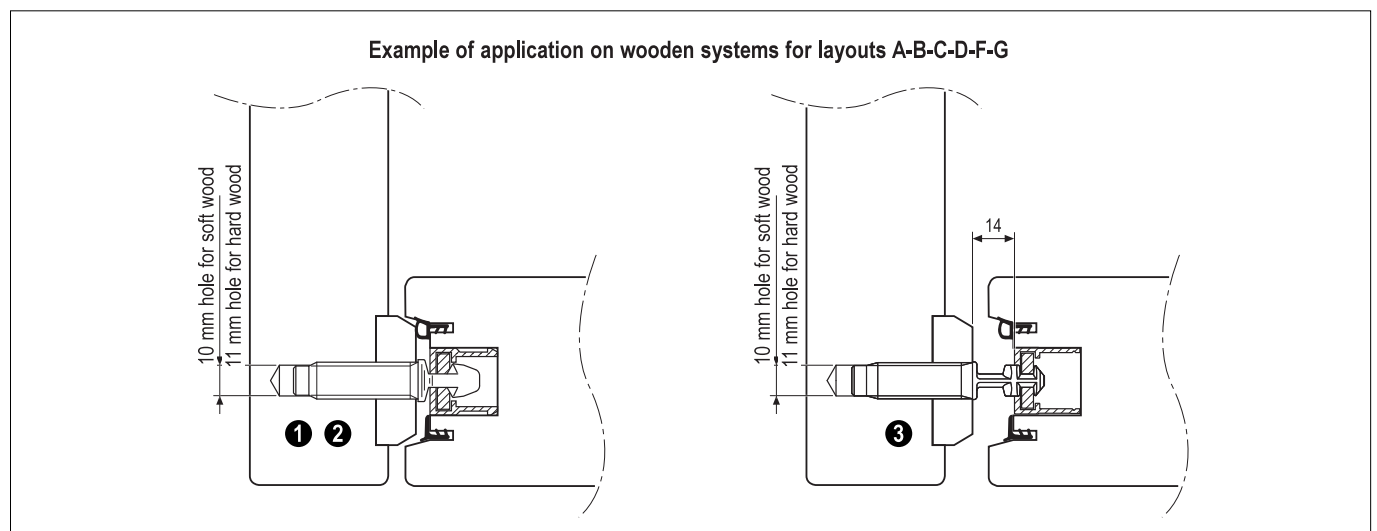
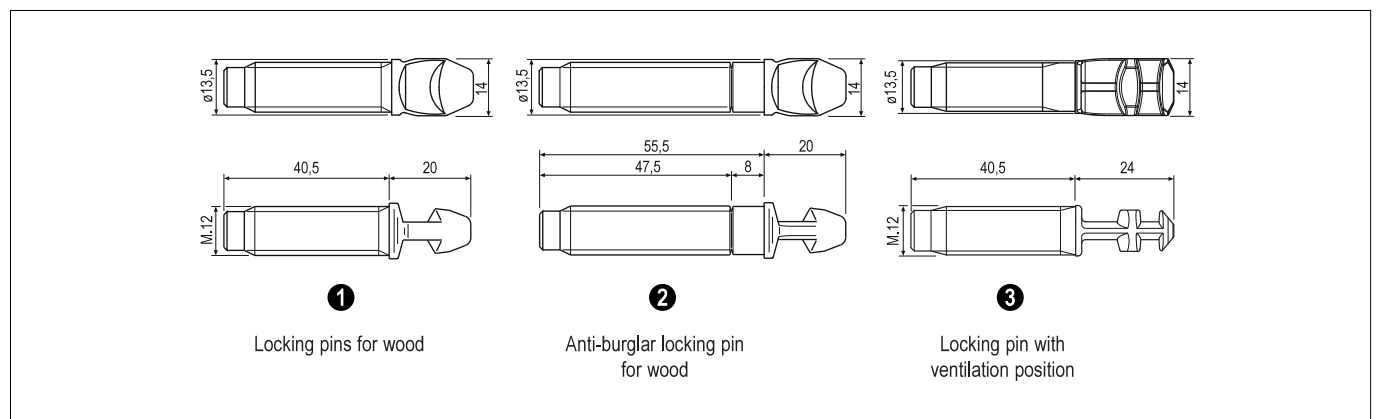

| Ref.     | Description                                 | Article        |
|----------|---|----------------|
| <b>1</b> | Wood  | G40728.00.03 * |
| <b>2</b> | Anti-burglar for wood                       | G40728.00.33 * |
| <b>3</b> | Ventilation for PVC / Aluminium-wood / Wood | G04902.01.00 * |

\* **Note.** Not included in the standard kit (to be ordered separately).

# Uni-V central point kit

## Description

Universal central point kit for all the AGB sliding systems.

## Use

The use of Uni-V central point offers many advantages:

- it binds the sashes in closing position;
- keeps the production fast because it doesn't need gasket holder profiles;
- helps the system tightness thanks to the increased gasket;
- helps the sash sliding thanks to wide working tolerances which are able to compensate the natural deformation of wood.

## Fastening

- a) Cut the components (follow the technical manual indications for each sliding system);
- b) insert the gasket;
- c) insert the terminal caps;
- d) fasten the profiles to sashes using screws  $\varnothing 3,5 \times 35$ ;
- e) insert the screws covering profiles and the brush;
- f) silicone and cut following the indications of the specific technical manual for each sliding system.

## Materials

- 1) EPDM gasket,
- 2) Covering profiles of screws in PVC,
- 3) Extruded aluminium profiles,
- 4) Polypropylene brush.

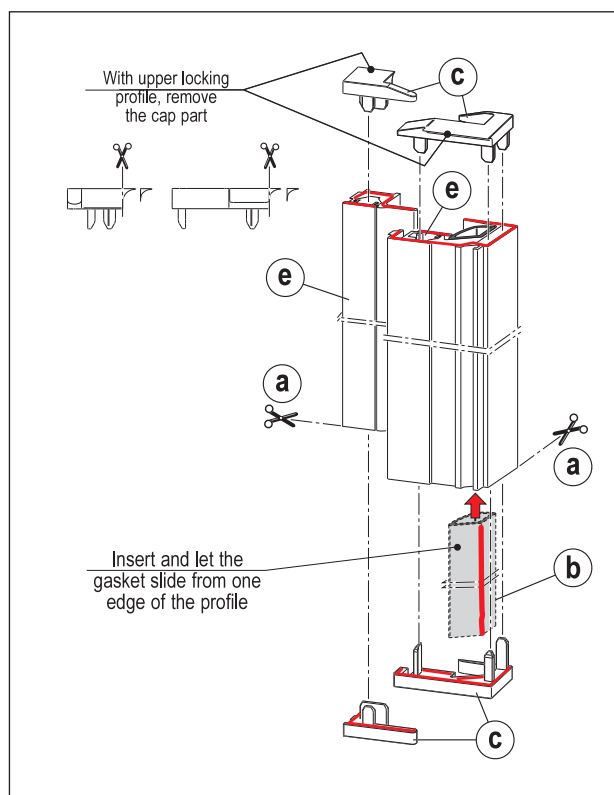
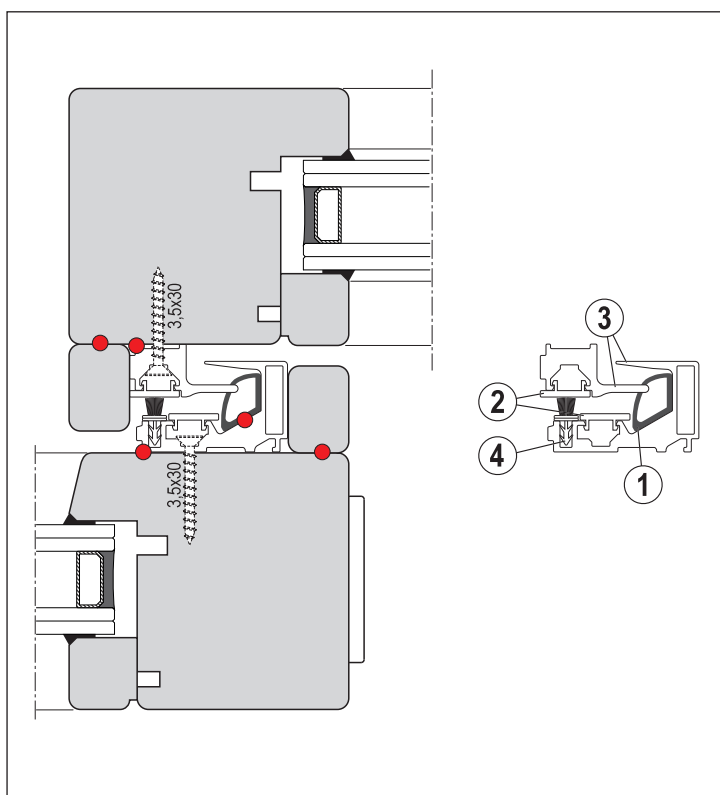

| Ref. | Article             | Article code | Finish | Length  |
|------|---------------------|--------------|--------|---------|
| 1    | Uni-V point profile | G02208.25.01 | Silver | 2500 mm |
|      |                     | G02208.25.93 | Black  | 2500 mm |
|      |                     | G02208.31.01 | Silver | 3100 mm |
|      |                     | G02208.31.93 | Black  | 3100 mm |
|      |                     | G02208.40.01 | Silver | 4000 mm |
|      |                     | G02208.40.93 | Black  | 4000 mm |

| Ref. | Article  | Article code |       |
|------|----------|--------------|-------|
| 2    | Caps kit | G01610.DX.93 | Right |
|      |          | G01610.SX.93 | Left  |



# Central point kit Uni-V mini

| Article            | Ref. | Description  | Use  | Fastening   |
|--------------------|------|--|--|---|
| Uni-V Mini profile | ❶    | Standard central point designed for the application in all the AGB lift&slide systems. | The use of Uni-V Mini central point has many advantages:<br>- it binds the sashes in closing position;<br>- it helps the lift&slide production because it does not require gasket profiles for rebate<br>- it helps the system tightness thanks to the increased gasket<br>- it helps the sashes sliding thanks to great working tolerances which are able to compensate the natural deformations of wood. | a) cut the components (follow the indications of the technical manual according to the lift&slide type to be designed),<br>b) insert the gasket,<br>c) insert the terminal caps,<br>d) fasten the profiles to sashes using screws $\varnothing 3,5 \times 35$ ,<br>e) insert the covering profiles of screws and the brush,<br>f) silicone and cut following the indications of the dedicated technical manual which concerns the lift&slide type to be designed. |
| Caps kit           | ❷    |  |  |   |

### Materials

- 1) EPDM gasket
- 2) PVC screws covering profiles
- 3) Extruded aluminium profiles
- 4) Polypropylene brush

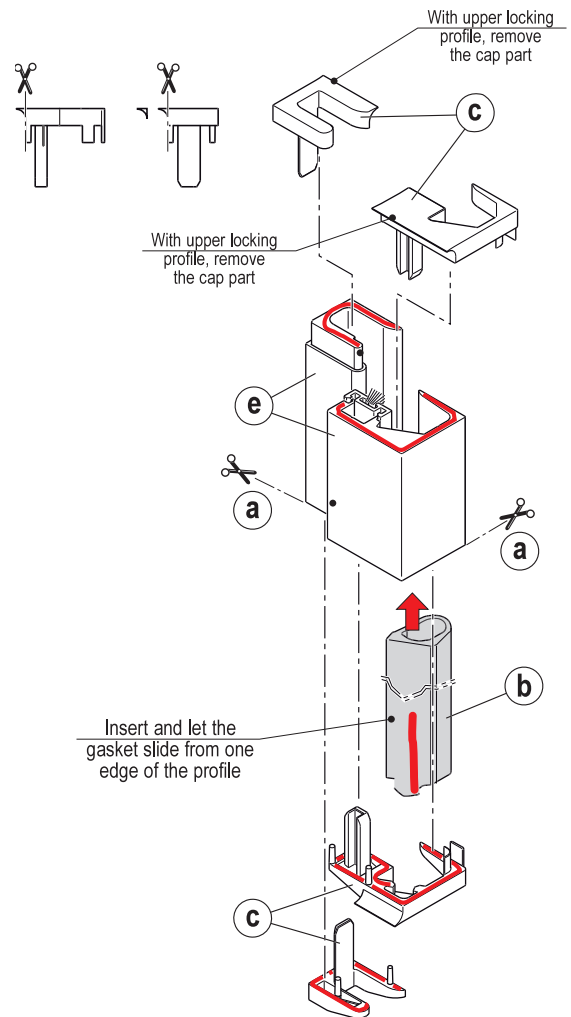
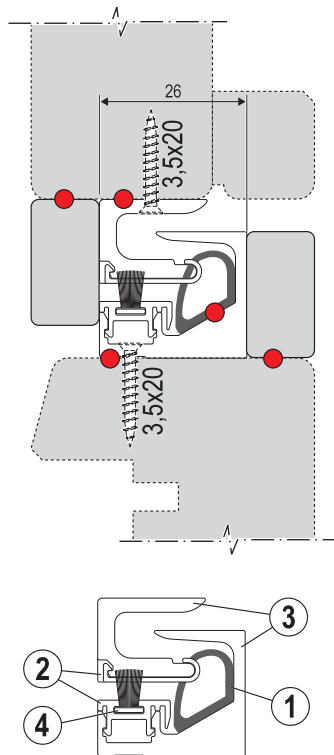

| Ref. | Article                  | Article code | Length  |
|------|--------------------------|--------------|---------|
| ❶    | Uni-V Mini point profile | G02211.25.01 | 2500 mm |
|      |                          | G02211.25.93 | 2500 mm |
|      |                          | G02211.31.01 | 3100 mm |
|      |                          | G02211.31.93 | 3100 mm |
|      |                          | G02211.40.01 | 4000 mm |
|      |                          | G02211.40.93 | 4000 mm |

| Ref. | Article  | Article code |       |
|------|----------|--------------|-------|
| ❷    | Caps kit | G01623.DX.93 | Right |
|      |          | G01623.SX.93 | Left  |







**Alban Giacomo SpA**

*Headquarters:*  
Via A. De Gasperi, 75  
36060 Romano d'Ezzelino  
(Vicenza) Italy